

NICHIAS

TOMBO™ BRAND GASKETS

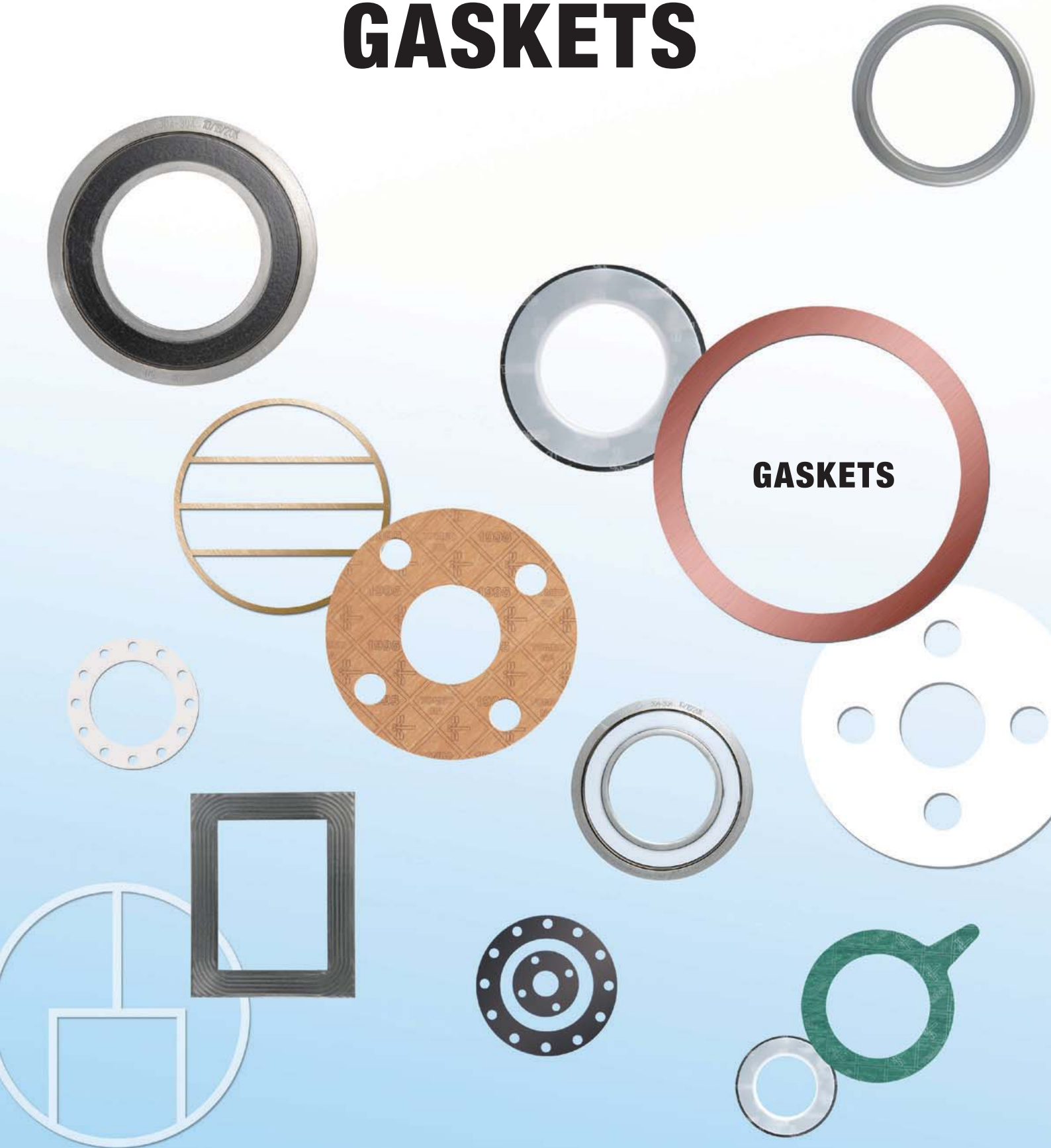

TOMBO™ BRAND GASKETS

TOMBO™ BRAND GASKETS

Gaskets play an important role in the prevention of fluid leakage from pipes and equipment parts, in a wide range of fields such as petroleum refining, chemical industry, shipping, construction, electric power, and steelmaking. Nichias pursues the satisfaction of the customer using its sophisticated “Insulation and Protection” technology.



NICHIAS

To ensure safe use

The physical properties, application selection, and other items indicated in this catalog are representative examples.

The performance data is based on the results on our test results and achievements in general applications. These products are used in various places and in various kinds of equipment. Also, the actual conditions of use differ from one product to another. For these reasons, it is recommended that before using a gasket, a confirmatory test should be carried out under the actual conditions of use.

Regarding individual applications, it is necessary to judge the selection after carrying out an evaluation of individual design and compatibility. Regarding special applications, please contact Nichias.

Please observe the following items in order to maintain the intrinsic functions of the products in this catalog and also to ensure that these products are used safely.

- 1) Do not use a product for any other than the original purpose described in this catalog.
- 2) When it is necessary to shape a product, use a tool that has a fine cutting edge.
- 3) When combining a product with a pipe or a piece of equipment, be sure to follow the instruction manual for the product concerned.
- 4) During repair, for example, if an old product remains at the location where it was installed, completely remove the old product before installing a new one.
- 5) Check the precautions for occupational health using the SDS (safety data sheet).

— Precautions for handling fluororesin products —

- 1) Do not use fluoropolymer products in human organ transplant and also do not bring fluoropolymer products into contact with bodily fluids or human tissue.
- 2) Do not use a product in an environment that the maximum service temperature indicated in the catalog is exceeded.
- 3) If a product is exposed to a temperature that exceeds the maximum service temperature (continuous) as indicated in the catalog, harmful gas may be generated. If such a condition occurs, adequately ventilate the area and be careful not to inhale the gas.

■ Storing gaskets

Store gaskets indoor at ordinary temperature and humidity and strictly avoid to get wet. If they are stored in a place where they are exposed to direct sunlight, ozone, high temperature, high humidity, or a corrosive environment, the materials of the gaskets will deteriorate.

Store gaskets horizontally on shelves, leaving them packed in order to prevent lodgment of dirt, and so on. Also, place a cushioning sheet between the gaskets.

Do not suspend a gasket from a hook, or store it with a heavy object placed on it, because this may cause the gasket to break.

■ Handling gaskets

When handling a gasket, avoid the following behavior because this will lead to deformation or deterioration of the sealing performance.

- Do not throw a gasket, tread on it, pull it, bend it, fold it, rub two gaskets together, hold a large diameter gasket in one hand, or shake a gasket while holding it.
- Do not reuse gaskets.

■ Disposing of gaskets

Dispose of used gaskets and scraps generated by shaping them in a dedicated disposal container and store and dispose of them separately from other items.

When disposing of such items, observe the related laws and regulations in your area. Do not incinerate these items. Note, however, that they can be incinerated using incinerating facilities that have suitable treatment equipment.

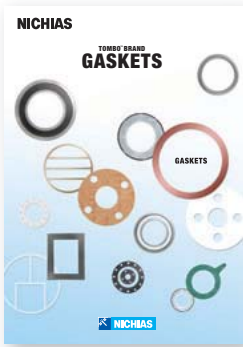

Concerning the use of this catalog

- *TOMBO™ is a registered trademark or trademark of Nichias Corporation.
- *NEVER-SEEZ is a trademark of Bostik, Inc.
- *SGM is a trademark of W. L. Gore & Associates, Inc.
- *JPI:The Japan Petroleum Institute
- ASTM:American International, formerly known as the American Society for Testing and Materials

POINT

The four methods are available for selecting a gasket.

1
Searching for a gasket from a product group or product name

2
Searching for a gasket from a product number

3
Searching for a gasket from a type of fluid system

4
Searching for a gasket from the service temperature and pressure

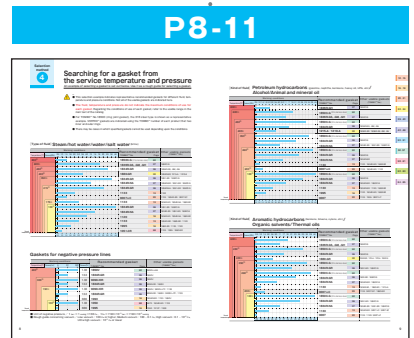
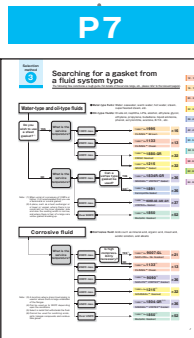
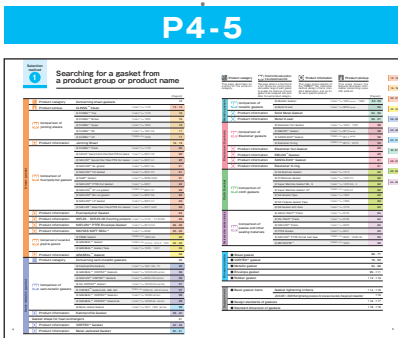

POINT

How to use this catalog



Product category

This page describes an outline of the product category.

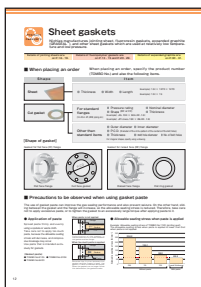

Product list that enables products to be compared to each other

This page, which is in the form of a list, shows the construction and usable range of each gasket to enable the features of each gasket to be compared with each other, for each product category.

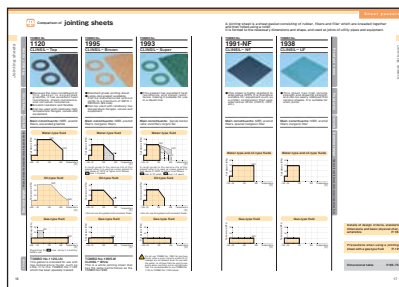

Product information

This page shows details of the TOMBO™ No. indication method, design criteria, standard dimensions, and so on, for each specific product.

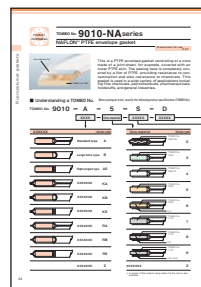

Product pickup

This page shows the features and basic information concerning a specific product.

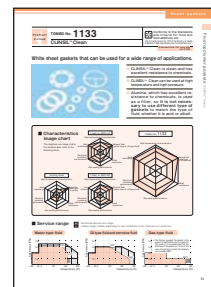

















Plus

Dimension table and supplement

Searching for a gasket from a product group or product name

[Page(s)]

Sheet gasket	 Product category	Concerning sheet gaskets	12	
	 Product pickup	CLINSIL™ Clean	TOMBO™ No.1133	13 – 15
	 Comparison of jointing sheets	● CLINSIL™ Top	TOMBO™ No.1120	16
		● CLINSIL™ Brown	TOMBO™ No.1995	16
		● CLINSIL™ Super	TOMBO™ No.1993	16
		● CLINSIL™ NF	TOMBO™ No.1991-NF	17
		● CLINSIL™ UF	TOMBO™ No.1938	17
	 Product information	Jointing Sheet		18 – 19
	 Comparison of fluoropolymer gaskets	● CLINSIL™ Clean	TOMBO™ No.1133	20
		● NAFLON™ Special Carbon Filler Filled PTFE Cut Gasket	TOMBO™ No.9007-SC	20
		● NAFLON™ PTFE Low Creep Cut Gasket	TOMBO™ No.9007-LC	20
		● NAFLON™ GL gasket	TOMBO™ No.9007-GL	21
		● NAFLON™ FD Gasket	TOMBO™ No.9007-FD	21
		● SGM™ Gasket	TOMBO™ No.9096-SGM	21
		● NAFLON™ PTFE Cut Gasket	TOMBO™ No.9007	22
		● NAFLON™ ST cut gasket	TOMBO™ No.9007-ST	22
		● NAFLON™ ML cut gasket	TOMBO™ No.9007-ML	22
		● NAFLON™ LP Gasket	TOMBO™ No.9007-LP	23
		● NAFLON™ Glass Fiber Filled PTFE Cut Gasket	TOMBO™ No.9007-G20	23
 Product information	Fluoropolymer Gasket		24	
 Product information	SOFLEX™ / SOFLEX™ -NK Punching products	TOMBO™ No.4140 / 4140-NK	25	
 Product information	NAFLON™ PTFE Envelope Gasket	TOMBO™ No.9010-NA	26 – 29	
 Product information	NICHIAS SOFT SEAL™	TOMBO™ No.9096	30 – 32	
 Comparison of expanded graphite gaskets	● CMGC Gasket	TOMBO™ No.1880-GR	32	
	● GRASEAL™ Gasket	TOMBO™ No.1215-A / 1210-A / 1200	32 – 33	
	● GRASEAL™ Gasket Tape	TOMBO™ No.1220 / 1221	33	
 Product information	GRASEAL™ Gasket		34	
Semi-metallic gasket	 Product category	Concerning semi-metallic gaskets	35	
	 Comparison of semi-metallic gaskets	● Kamprofile Gaskets	TOMBO™ No.1891-GR, -TF	36
		● GRASEAL™ VORTEX™ Gaskets	TOMBO™ No.1834R-GR series	36
		● NAFLON™ VORTEX™ Gaskets	TOMBO™ No.9090-IOR series	36
		● NA VORTEX™ Gasket	TOMBO™ No.1834R-NA series	37
		● VORTEX™ Gasket-GS, -GM, -GH	TOMBO™ No.1836R-GS, -GM-GH series	37
		● GRASEAL™ VORTEX™ Gasket-L	TOMBO™ No.1839R series	38
		● GRASEAL™ VORTEX™ Gasket-AL	TOMBO™ No.1839R-AL series	38
		● Metal Jacket Gasket	TOMBO™ No.1841, 1861 series	38
	 Product information	Kamprofile Gasket		39 – 40
	Gasket shape for heat exchangers			41
	 Product information	VORTEX™ Gasket		42 – 49
	 Product information	Metal Jacketed Gasket		50 – 51



Product category

This page describes an outline of the product category.



Product list that enables products to be compared to each other

This page, which is in the form of a list, shows the construction and usable range of each gasket to enable the features of each gasket to be compared with each other, for each product category.



Product information

This page shows details of the TOMBO™ No. indication method, design criteria, standard dimensions, and so on, for each specific product.



Product pickup

This page shows the features and basic information concerning a specific product.

12 - 15

16 - 19

20 - 31

32 - 34

39 - 40

42 - 49

50 - 51

52 - 57

58 - 61

62 - 63

64 - 65

[Page(s)]

Metallic gaskets	Comparison of metallic gaskets	● Metallic Gasket	TOMBO™ No.1850 series / 1890	52 - 53
		● Metal O-seal	TOMBO™ No.9200 series	53
	Product information	Solid Metal Gasket		54 - 55
	Product information	Metal O-seal		56 - 57
Elastomer Gaskets	Comparison of elastomer gaskets	● Elastomer Cut Gasket	TOMBO™ No.1050 / 1051	58
		● EBILON™ Gasket	TOMBO™ No.9013 series	58
		● SANICLEAN™ Gasket	TOMBO™ No.9014 series	59
		● Elastomer O-ring / BLAZER™ O-ring	TOMBO™ No.2670 / 2675	59
	Product information	Elastomer Cut Gasket		60
	Product information	EBILON™ Gasket		60
	Product information	SANICLEAN™ Gasket		61
	Product information	Elastomer O-ring		61
Cloth Gasket	Comparison of cloth gaskets	● NA Manhole Gasket	TOMBO™ No.1374	62
		● FF Manhole Gasket	TOMBO™ No.1400-TH	62
		● Super Manhole Gasket NA, -S	TOMBO™ No.1400-NA, -S	62
		● Super Manhole Gasket -ST	TOMBO™ No.1400-ST	62
		● NA Gasket Tape	TOMBO™ No.1364	63
		● NA Tadpole Gasket Tape	TOMBO™ No.1368	63
		● NA Gasket with Core	TOMBO™ No.1378	63
		Paste and other sealing materials	Comparison of pastes and other sealing materials	● AQUA-TIGHT™ Paste
● OIL-TIGHT™ Paste	TOMBO™ No.9106			64
● NAFLON™ Paste	TOMBO™ No.9400			64
● PTFE Grease	TOMBO™ No.9401			65
● NAFLON™ PTFE thread seal tape	TOMBO™ No.9082 / 9082-BL			65
● METAKOTE™	TOMBO™ No.1600			65

Dimension table	■ Sheet gasket	68 - 77
	■ VORTEX™ gasket	78 - 93
	■ Metallic gasket	94 - 98
	■ Envelope gasket	99 - 111
	■ Rubber gasket	112 - 113

Supplement	■ Basic gasket items	Gasket tightening criteria	114 - 115
		JIS B 2251 : 2008 "Bolt tightening procedure for pressure boundary flanged joint Assembly"	115
	■ Design standards of gaskets		116 - 117
	■ Standard dimension of gaskets		118 - 119

Searching for a gasket from a product number (TOMBO™ No.)

Product number (TOMBO™ No.)	Product number	Page(s)
1050	Elastomer Cut Gasket	58
1051	Elastomer Cut Gasket	58
1120	CLINSIL™ Top	16
1133	CLINSIL™ Clean	13–15
1200	GRASEAL™ Gasket	33
1210	GRASEAL™ Gasket	32
1215	GRASEAL™ Gasket	32
1220	GRASEAL™ Gasket Tape	33
1221	GRASEAL™ Gasket Tape	33
1364	NA Gasket Tape	63
1368	NA Tadpole Gasket Tape	63
1374	NA Manhole Gasket	62
1378	NA tadpole Gasket	63
1400-NA	Super Manhole Gasket-NA	62
1400-S	Super Manhole Gasket-S	62
1400-ST	Super Manhole Gasket-ST	62
1400-TH	FF Manhole Gasket	62
1600	METAKOTE™	65
1834R-GR series	GRASEAL™ VORTEX™ Gasket	36
1834R-NA series	NA VORTEX™ Gasket	37
1836R-GH series	VORTEX™ Gasket-GH	37
1836R-GM series	VORTEX™ Gasket-GM	37
1836R-GS series	VORTEX™ Gasket-GS	37
1839R-AL series	GRASEAL™ VORTEX™ Gasket-AL	38
1839R series	GRASEAL™ VORTEX™ Gasket-L	38
1841 series	Metal Jacketed Gasket	38
1861 series	Metal Jacketed Gasket	38
1850 series	Metallic Gasket	52
1890	Metallic Gasket	53
1880-GR	CMGC gasket	32
1891-GR	Kammprofile Gasket	36
1891-TF	Kammprofile Gasket	36

Product number (TOMBO™ No.)	Product number	Page(s)
1938	CLINSIL™ UF	17
1991-NF	CLINSIL™ NF	17
1993	CLINSIL™ Super	16
1995	CLINSIL™ Brown	16
2670	Elastomer O-ring	59
4140	SOFLEX™	25
4140-NK	SOFLEX™-NK Punching products	25
9007	NAFLON™ PTFE Cut Gasket	22
9007-FD	NAFLON™ FD Gasket	21
9007-G20	NAFLON™ Glass Fiber-Filled PTFE Cut Gasket	23
9007-GL	NAFLON™ GL Gasket	21
9007-LC	NAFLON™ PTFE Low Creep Cut Gasket	20
9007-LP	NAFLON™ LP Gasket	23
9007-ML	NAFLON™ ML Cut Gasket	22
9007-SC	NAFLON™ Special Carbon Filler Filled PTFE Cut Gasket	20
9007-ST	NAFLON™ ST Cut Gasket	22
9010-NA	NAFLON™ PTFE Envelope Gasket	26–29
9013	EBILON™ Gasket	58
9014	SANICLEAN™ Gasket	59
9082-BL	NAFLON™ PTFE thread seal tape	65
9090-IOR series	NAFLON™ VORTEX™ Gasket	36
9096	NICHIAS SOFT SEAL™	30–31
9096-SGM	SGM™ Gasket	21
9105	AQUA-TIGHT™ Paste	64
9106	OIL-TIGHT™ Paste	64
9200	Metal O-seal	56–57
9400	NAFLON™ Paste	64
9401	PTFE Grease	65
—	Irregular-shape VORTEX™ Gasket	43
—	Heat Exchanger VORTEX™ Gasket with Pass Ribs	43
—	Metal Jacketed Gasket with GRASEAL™ Tape	50
—	Metal Jacketed Heat Exchanger Gasket	50

Searching for a gasket from a fluid system type

The following flow constitutes a rough guide. For details of the service range, etc., please refer to the relevant page(s).

12 - 15

16 - 19

20 - 31

32 - 34

39 - 40

42 - 49

50 - 51

52 - 57

58 - 61

62 - 63

64 - 65

Water-type and oil-type fluids

- Water-type fluids: Water, seawater, warm water, hot water, steam, superheated steam, etc.
- Oil-type fluids: Crude oil, naphtha, LPG, alcohol, ethylene glycol, ethylene, propylene, butadiene, liquid ammonia, phenol, acrylonitrile, acetone, B.T.X., etc.

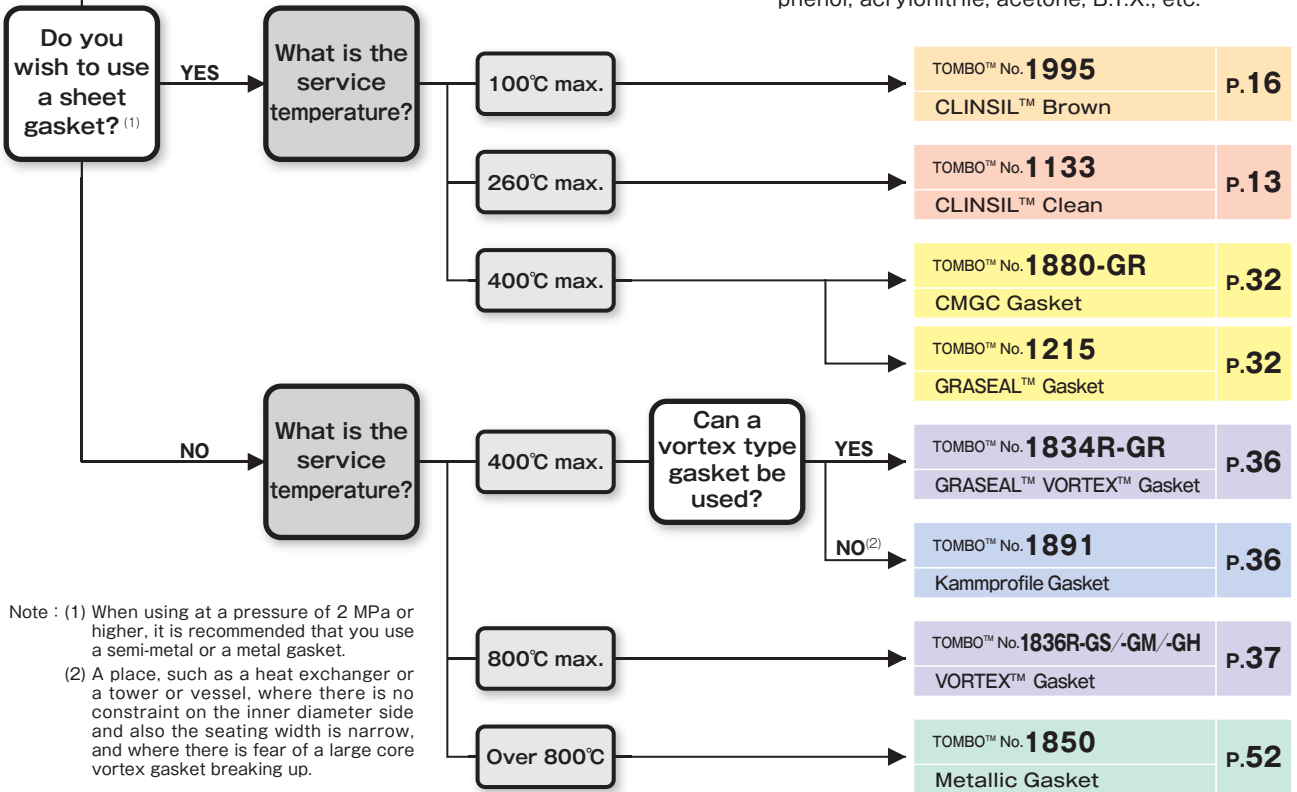

Corrosive fluid

- Corrosive fluid: Acids such as mineral acid, organic acid, mixed acid, acidic solution, and alkalis

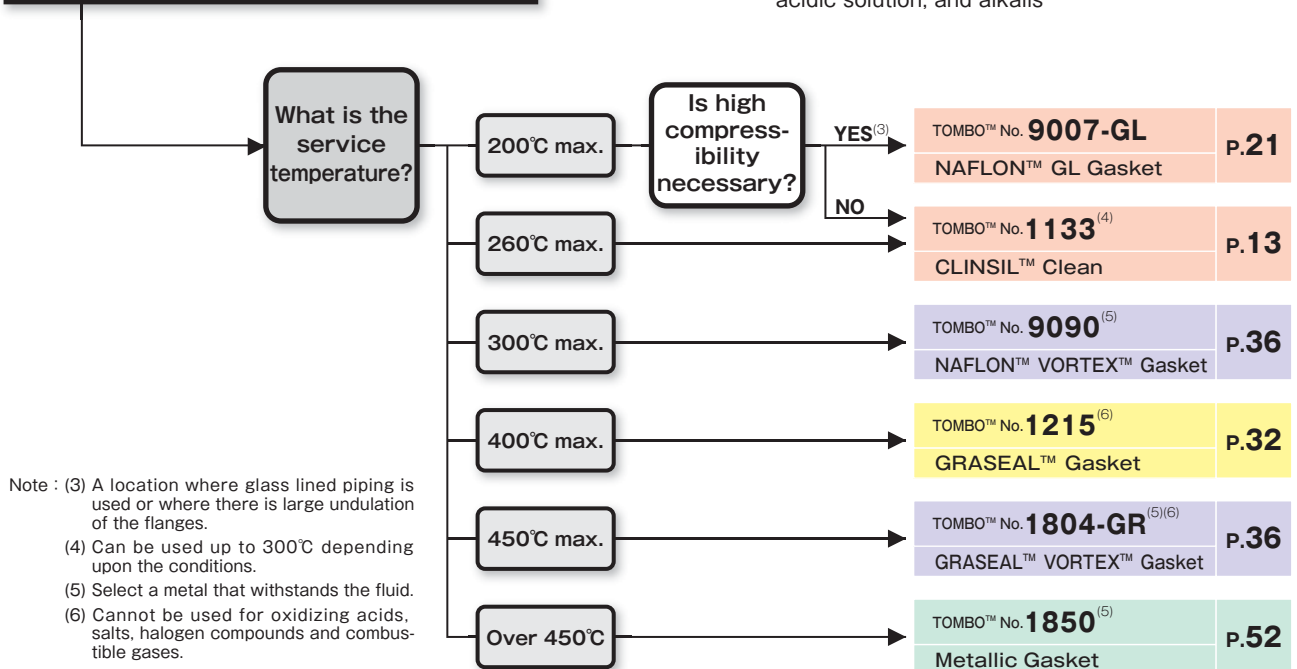

Searching for a gasket from the service temperature and pressure

An example of selecting a gasket is set out below. Use it as a rough guide for selecting a gasket.



- This selection example indicates representative recommended gaskets for different fluid, temperature and pressure conditions. Not all of the usable gaskets are indicated here.
- **The fluid, temperature and pressure do not indicate the maximum conditions of use for each gasket.** Regarding the conditions of use of each gasket, refer to the usable range in the main text of the catalog.
- For TOMBO™ No.1850C (ring joint gasket), the 316 steel type is shown as a representative example. VORTEX™ gaskets are indicated using the TOMBO™ number of each product that has inner and outer rings.
- There may be cases in which specified gaskets cannot be used depending upon the conditions.

[Type of fluid] **Steam/hot water/water/salt water** (brine)

Working conditions		Recommended gasket		Other usable gaskets (TOMBO™ No.)
Temperature[°C]	Pressure[MPa]	TOMBO™ No.	Page	
800°C	0.5 - 44	1850C-G (316 stainless steel)	52	
600°C	0.5 - 18	1836R-GS, -GM, -GH	37	1850C-G
450°C	0.5 - 29	1834R-GR	36	1836R-GS, -GM, -GH
400°C	0.5 - 12	1880-GR	32	1834R-GR, 1215-A / 1210-A
350°C	0.5 - 20	1834R-GR	36	1891-GR / 1850C-G
215°C	0.5 - 12	1834R-NA	37	1834R-GR / 1891-GR / 1850C-G
215°C	0.5 - 20	1834R-GR	36	1834R-NA / 1891-GR / 1850C-G
175°C	0.5 - 3.6	1133	13	1120
175°C	0.5 - 3.6	1133	13	1834R-GR / 1834R-NA / 1880-GR / 9007-LC
100°C	0.5 - 44	1834R-GR	36	1891-GR / 1850C-G
100°C	0.5 - 16	1834R-NA	37	1834R-GR / 1891-GR / 1850C-G
100°C	0.5 - 4.0	1120	16	1834R-GR / 1834R-NA / 1880-GR
100°C	0.5 - 3.0	1133	13	1834R-GR / 1880-GR / 1120
Normal temperature	0.5 - 1.8	1995	16	1880-GR / 1133 / 1120
Normal temperature	0.5 - 44	1051-CR	58	1133 / 1995 / 1880-GR

Gaskets for negative pressure lines

Working conditions		Recommended gasket		Other usable gaskets (TOMBO™ No.)
Temperature[°C]	Pressure[torr]	TOMBO™ No.	Page	
400°C	5 - 0.01	1.33 1850V	52	9200V-JAG
400°C	5 - 0.01	13.3 1834R-GR	36	1850V
300°C	5 - 0.01	1.33 9090-IOR	36	1850V
300°C	5 - 0.01	13.3 1834R-GR	36	9090-IOR / 1850V
150°C	5 - 0.01	1.33 9090-IOR	36	1850V / 9200V-JTF / 1133
150°C	5 - 0.01	13.3 1834R-GR	36	9090-IOR / 1850V / 9200V-JTF / 1133
100°C	5 - 0.01	666 1133	16	1834R-GR / 1120 / 1850V
100°C	5 - 0.01	1.33 1050	58	2670 / 1834R-GR / 1133
Normal temperature	5 - 0.01	666 1995	16	1050 / 1215T / 1993

■ Unit of negative pressure / 1 torr = 1 mmHg = 133 Pa, 1 Pa = 7.50 × 10⁻³ torr = 7.50 × 10⁻³ mmHg
 ■ Rough guide concerning vacuum / Low vacuum : 100 Pa or higher, Medium vacuum : 100 - 0.1 Pa, High vacuum : 0.1 - 10⁻⁵ Pa, Ultra-high vacuum : 10⁻⁵ Pa or lower

[Kind of fluid] **Petroleum hydrocarbons** (gasoline, naphtha, kerosene, heavy oil, LPG, etc.)/
Alcohol/Animal and mineral oil

Working conditions		Recommended gasket		Other usable gaskets
Temperature[°C]	Pressure[MPa]	TOMBO™ No.	Page	(TOMBO™ No.)
800°C	0.5	1836R-GH	37	1850C-G
	1.0			
600°C	0.5	1850C-G (316 stainless steel)	52	
	1.0			
450°C	0.5	1836R-GS, -GM, -GH	37	1850C-G
	1.0			
400°C	0.5	1850C-G (316 stainless steel)	52	
	1.0			
350°C	0.5	1834R-GR	36	1836R-GS, -GM, -GH
	1.0			
260°C	0.5	1215-A / 1210-A	32	1834R-GR / 1836R-GS, -GM, -GH
	1.0			
200°C	0.5	1850C-G (316 stainless steel)	52	
	1.0			
100°C	0.5	1834R-GR	36	1850C-G
	1.0			
Normal temperature	0.5	1834R-NA	37	1834R-GR / 1891-GR / 1850C-G
	1.0			
Normal temperature	0.5	1133	13	1120 / 1834R-GR / 1880-GR
	1.0			
Normal temperature	0.5	9007-LC	20	1133 / 1834R-GR / 1120
	1.0			
Normal temperature	0.5	1850C-G (316 stainless steel)	52	
	1.0			
Normal temperature	0.5	1834R-GR	36	1850C-G
	1.0			
Normal temperature	0.5	1834R-NA	37	1834R-GR / 1850C-G
	1.0			
Normal temperature	0.5	1133	13	1834R-GR / 1120 / 1880-GR
	1.0			
Normal temperature	0.5	1995	16	1120 / 1834R-GR / 1880-GR
	1.0			
Normal temperature	0.5	9007	22	1133 / 1995 / 9007-LP
	1.0			

[Kind of fluid] **Aromatic hydrocarbons** (benzene, toluene, xylene, etc.)/
Organic solvents/Thermal oils

Working conditions		Recommended gasket		Other usable gaskets
Temperature[°C]	Pressure[MPa]	TOMBO™ No.	Page	(TOMBO™ No.)
600°C	0.5	1850C-G (316 stainless steel)	52	
	1.0			
450°C	0.5	1836R-GS, -GM, -GH	37	1850C-G
	1.0			
400°C	0.5	1850C-G (316 stainless steel)	52	
	1.0			
350°C	0.5	1834R-GR	36	1850C-G
	1.0			
260°C	0.5	1880-GR	32	1834R-GR / 1215-A / 1210-A / 1850C-G
	1.0			
200°C	0.5	1850C-G (316 stainless steel)	52	
	1.0			
100°C	0.5	1834R-GR	36	1891-GR / 1850C-G
	1.0			
Normal temperature	0.5	1834R-GR	36	1891-GR / 1850C-G
	1.0			
Normal temperature	0.5	1834R-NA	37	1834R-GR / 1850C-G
	1.0			
Normal temperature	0.5	1133	13	1834R-GR / 1880-GR / 1215-A
	1.0			
Normal temperature	0.5	9007-LC	20	1133 / 9007-SC / 1880-GR
	1.0			
Normal temperature	0.5	1850C-G (316 stainless steel)	52	
	1.0			
Normal temperature	0.5	1834R-GR	36	1891-GR / 1850C-G
	1.0			
Normal temperature	0.5	1834R-NA	37	1834R-GR / 1891-GR / 1850C-G
	1.0			
Normal temperature	0.5	1133	13	1834R-GR / 9007-LC / 9007-SC
	1.0			
Normal temperature	0.5	9007	22	1133 / 1120 / 9007-LP
	1.0			

[Kind of fluid] **Weak acids** (acetic acid, carbonic acid, etc.)/**Weak alkalis** (ammonia, etc.)/**Saline**

Working conditions		Recommended gasket		Other usable gaskets			
Temperature[°C]	Pressure[MPa]	TOMBO™ No.	Page	(TOMBO™ No.)			
Normal temperature 260°C 200°C 100°C	0.5	1834R-GR	36	1891-GR			
	1.0						
	1.5						
	1.8						
	3.0						
	4.6						
	9.0						
	11						
	0.5				1215-A / 1210-A	32	1834R-GR / 1891-GR
	1.0						
1.5							
0.5	1133	13	1880-GR / 1215-A / 1210-A / 1120				
1.0							
1.5							
0.5	9007-LC	20	1133 / 1834R-GR				
1.0							
1.5							
0.5	1834R-GR	36					
1.0							
1.5							
0.5	1133	13	1834R-GR / 1215-A / 1210-A				
1.0							
1.5							
0.5	1995	16	1133 / 1880-GR / 1120				
1.0							
1.5							
0.5	9007	22	1133 / 1880-GR / 1120				
1.0							
1.5							

[Kind of fluid] **Strong acids** (sulfuric acid, hydrochloric acid, nitric acid, etc.)

Working conditions		Recommended gasket		Other usable gaskets			
Temperature[°C]	Pressure[MPa]	TOMBO™ No.	Page	(TOMBO™ No.)			
Normal temperature 260°C 200°C 100°C	0.5	9090-IOR ⁽¹⁾	36				
	1.0						
	1.5						
	1.8						
	3.0						
	4.6						
	9.0						
	11						
	0.5				1133	13	9090-IOR ⁽¹⁾
	1.0						
1.5							
0.5	9007-LC	20	1133 / 9090-IOR ⁽¹⁾				
1.0							
1.5							
0.5	9090-IOR ⁽¹⁾	36					
1.0							
1.5							
0.5	1133	13	9090-IOR ⁽¹⁾				
1.0							
1.5							
0.5	9007-LC	20	1133 / 9090-IOR ⁽¹⁾				
1.0							
1.5							
0.5	9007	22	1133 / 9090-IOR ⁽¹⁾				
1.0							
1.5							

Note : (1) Select a metal that withstands the fluid.

[Kind of fluid] **Strong alkalis** (caustic soda, caustic potash, etc.)

Working conditions		Recommended gasket		Other usable gaskets			
Temperature[°C]	Pressure[MPa]	TOMBO™ No.	Page	(TOMBO™ No.)			
Normal temperature 260°C 200°C 120°C 100°C	0.5	1834R-GR	36	1891-GR			
	1.5						
	1.8						
	3.0						
	4.6						
	9.0						
	11						
	0.5				1215-A / 1210-A	32	1834R-GR / 1891-GR / 1880-GR
	1.5						
	1.8						
0.5	9007-SC	20	1834R-GR / 1880-GR / 1215-A / 1210-A				
1.5							
1.8							
0.5	1133 ⁽²⁾	13	1834R-GR / 9007-SC / 1215-A / 1210-A				
1.5							
1.8							
0.5	1834R-GR	36	1834R-NA				
1.5							
1.8							
0.5	1133	13	1834R-GR / 1834R-NA / 1215-A / 1210-A				
1.5							
1.8							
0.5	9007-SC	20	1133 / 1834R-GR / 1120				
1.5							
1.8							
0.5	9007	22	1133 / 1834R-GR / 9007-SC				
1.5							
1.8							

Note : (2) Use at a fluid concentration of no more than 30%.

[Kind of fluid] **Air**

Working conditions		Recommended gasket		Other usable gaskets			
Temperature[°C]	Pressure[MPa]	TOMBO™ No.	Page	(TOMBO™ No.)			
Normal temperature 600°C 300°C 260°C 200°C 100°C	0.3	1841-FI-G ⁽³⁾	38				
	0.5						
	1.0						
	1.5						
	5.0						
	0.3				1834R-GR	36	1841-FI-G ⁽³⁾ / 1891-GR / 1850C-G
	0.5						
1.0							
0.3	1133	13	1834R-GR / 1880-GR / 1120				
0.5							
1.0							
0.3	9007-LC	20	1133 / 1880-GR / 1120				
0.5							
1.0							
0.3	1995 ⁽³⁾	16	1133 / 1834R-GR / 1050 series				
0.5							
1.0							
0.3	9007	22	1133 / 1834R-GR / 1995 ⁽³⁾				
0.5							
1.0							

Note : (3) Use gasket paste.

[Kind of fluid] Exhaust gas

Working conditions		Recommended gasket		Other usable gaskets (TOMBO™ No.)
Temperature[°C]	Pressure[MPa]	TOMBO™ No.	Page	
700°C	0.01 - 1.0	1400-ST ⁽⁴⁾	62	1400-S ⁽⁴⁾
500°C	0.01 - 1.0	1400-TH ⁽⁴⁾	62	1400-ST ⁽⁴⁾ / 1400-S ⁽⁴⁾ / 1400-NA ⁽⁴⁾
300°C	0.01 - 1.0	1374 ⁽⁴⁾	62	1400-ST ⁽⁴⁾ / 1400-TH ⁽⁴⁾ / 1400-NA ⁽⁴⁾
260°C	0.01 - 1.0	1133	13	
200°C	0.01 - 1.0	1120	16	1133 / 1834R-GR
100°C	0.01 - 1.0	1995	16	1133 / 1834R-GR / 1120

Note : (4) Use at locations where a certain amount of leakage is tolerated.

[Kind of fluid] Combustible gas/Toxic gas/Hydrogen gas/Ammonia

Working conditions		Recommended gasket		Other usable gaskets (TOMBO™ No.)
Temperature[°C]	Pressure[MPa]	TOMBO™ No.	Page	
600°C	0.5 - 39	1850C-G (316 stainless steel)	52	
450°C	0.5 - 39	1850C-G (316 stainless steel)	52	
350°C	0.5 - 39	1834R-GR	36	1850C-G
	0.5 - 39	1850C-G (316 stainless steel)	52	
260°C	0.5 - 39	1834R-GR	36	1891-GR / 1850C-G
	0.5 - 39	1834R-NA	37	1834R-GR / 1891-GR / 1850C-G
200°C	0.5 - 39	1850C-G (316 stainless steel)	52	
	0.5 - 39	1834R-GR	36	1891-GR / 1850C-G
100°C	0.5 - 39	9090-IOR	36	1834R-GR / 1891-GR / 1850C-G
	0.5 - 39	1834R-NA	37	1834R-GR / 9090-IOR / 1891-GR
Normal temperature	0.5 - 39	1133	13	1834R-GR / 9090-IOR / 1834R-NA
	0.5 - 39	9007-LC	20	1133 / 1834R-GR / 9090-IOR
Normal temperature	0.5 - 39	9007	22	1133 / 1834R-GR / 9007-LP

[Kind of fluid] Oxygen gas

Working conditions		Recommended gasket		Other usable gaskets (TOMBO™ No.)
Temperature[°C]	Pressure[MPa]	TOMBO™ No.	Page	
260°C	1.0 - 39	1850C-G (316 stainless steel)	52	
100°C	1.0 - 39	9090-IOR-OX	36	
	1.0 - 39	1133	13	9090-IOR-OX
Normal temperature	1.0 - 39	1133	13	9007-LC / 9090-IOR-OX

[Kind of fluid] Low-temperature fluid/Liquefied gas/LNG/LN₂/LO₂/Ethylene

Working conditions		Recommended gasket		Other usable gaskets (TOMBO™ No.)
Temperature[°C]	Pressure[MPa]	TOMBO™ No.	Page	
-200°C	1.0 - 39	1133	13	1120-LN / 1839R
-240°C	1.0 - 39	1834R-GR	36	
	1.0 - 39	1839R	38	



Sheet gaskets

Nichias manufactures jointing sheet, fluororesin gaskets, expanded graphite (GRASEAL™), and other sheet gaskets which are used at relatively low temperature and low pressure.



Details of jointing sheets are on P.16 - 19.

Details of fluoropolymer gaskets are on P.13 - 15 and P.20 - 31.

Details of expanded graphite are on P.32 - 34.

When placing an order

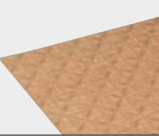
When placing an order, specify the product number (TOMBO™ No.) and also the following items.

Shape	Item
<p>Sheet</p> 	<ul style="list-style-type: none"> ● Thickness ● Width ● Length <p>Example) 1.5t × 1270 × 1270 Example) 1.5t × 1S</p>
<p>Cut gasket</p> 	<p>For standard flanges (for JIS or JPI (ANSI) piping, etc.)</p> <ul style="list-style-type: none"> ● Pressure rating ● Shape (RF or FF) ● Nominal diameter ● Thickness <p>Example) JIS, 10K × 50A, RF, 1.5t Example) JPI class, 150 × 2B, RF, 1.5t</p>
	<p>Other than standard items</p> <ul style="list-style-type: none"> ● Outer diameter ● Inner diameter ● P.C.D. (Diameter of the circle pattern of the centers of the bolt holes) ● Thickness ● Bolt hole diameter ● No. of bolt holes <p>For irregular shapes, specify using a drawing.</p>

[Shape of gasket]

Gasket for flat face (FF) flange

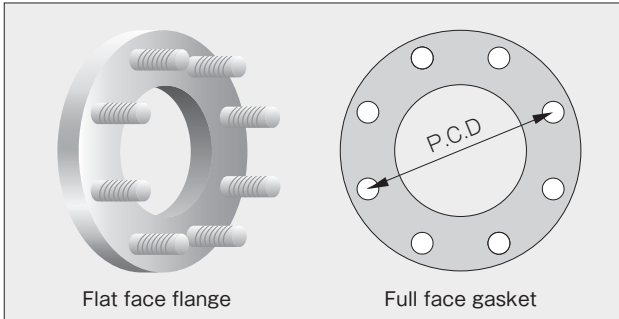

Gasket for raised face (RF) flange

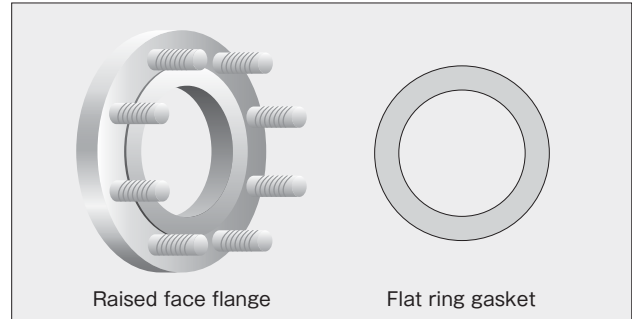

Precautions to be observed when using gasket paste

The use of gasket paste can improve the gas sealing performance and also prevent seizure. On the other hand, sliding between the gasket and the flange will increase, so the allowable seating stress is reduced. Therefore, take care not to apply excessive paste, or to tighten the gasket to an excessively large torque after applying paste to it.

Application of paste

Spread paste thinly and evenly using a spatula or waste cloth. Take care not to apply too much paste, because the allowable seating stress will decrease, and compressive breakage may occur. Use paste that is intended exclusively for gaskets.

(Gasket paste)

- TOMBO™ No.9105
- TOMBO™ No.9106
- TOMBO™ No.9400

When paste is not applied

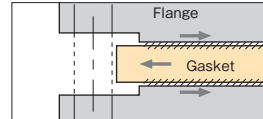

Deformation of the gasket is suppressed due to friction between the gasket and the flange.

When too much paste is applied

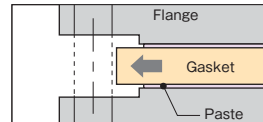

Because the friction between the gasket and the flange is small, the gasket is liable to become deformed. When the gasket can no longer follow this deformation, the gasket breaks.

Allowable seating stress when paste is applied

Example: Allowable seating stress of TOMBO™ No.1120 (jointing seat). The allowable seating stress when paste is applied is lower than that when paste is not applied.

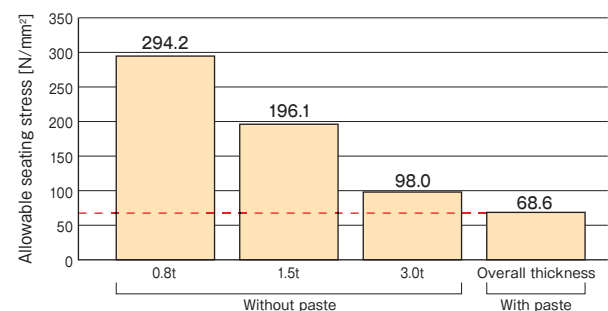



TOMBO™ No. 1133
CLINSIL™ Clean



Conforms to the Standards and criteria for food and food additives, etc.

(3-D-2, Public Notice No. 370 of the Ministry of Health & Welfare, 1959) stipulated by the Food Sanitation Act

Precautions for use are on P.24.

White sheet gaskets that can be used for a wide range of applications.

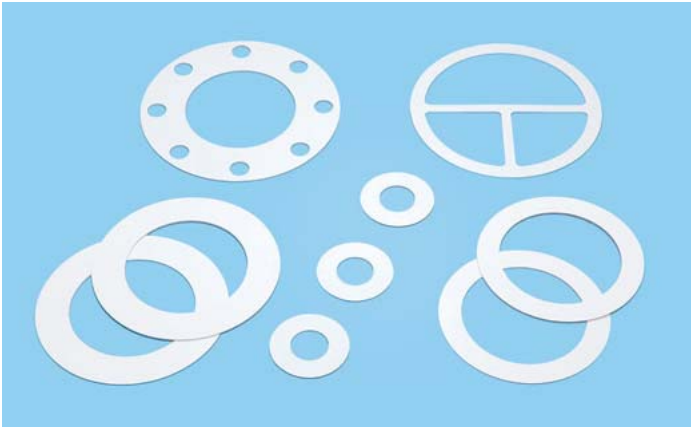

- CLINSIL™ Clean is clean and has excellent resistance to chemicals.
- CLINSIL™ Clean can be used at high temperature and high pressure.
- Alumina, which has excellent resistance to chemicals, is used as a filler, so it is not necessary to use different type of gaskets to match the type of fluid, whether it is acid or alkali.

Characteristics image chart

The diagrams are image charts. For detailed data, refer to the following items.

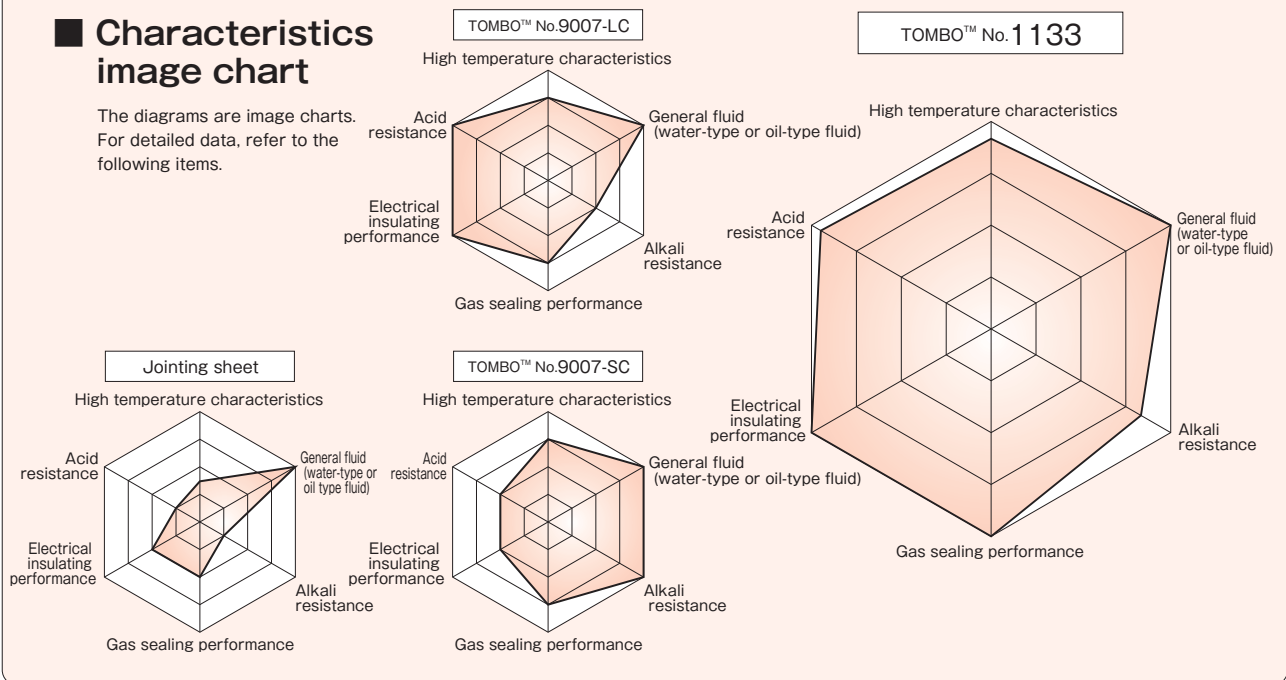

Service range

Recommended service range
 Usable range (Usable depending on the conditions of use. Consult us in advance.)

Water-type fluid

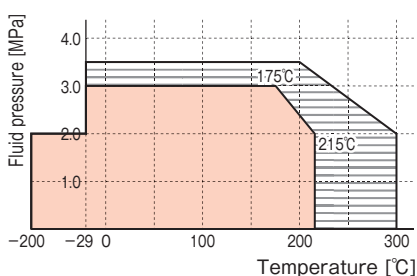

Oil-type fluid and corrosive fluid

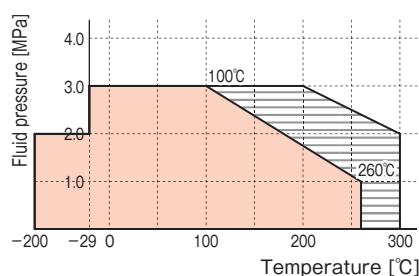

Gas-type fluid

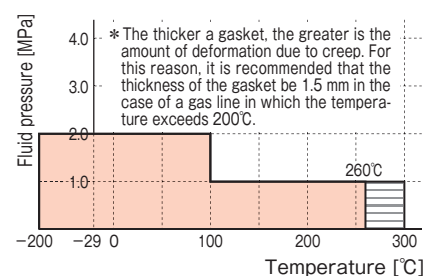

■ Design criteria

TOMBO™ No.		1133
Gasket factor m	[—]	
	1.0 t	3.50
	1.5 t	2.75
	2.0 t	2.75
Minimum designed seating stress γ	[N/mm ²]	
	1.0 t	44.8
	1.5 t	25.5
	2.0 t	25.5
Minimum seating stress σ_3	[N/mm ²]	
	Water-type or oil-type fluid	14.7
Allowable seating stress	[N/mm ²]	
	Gas-type fluid	34.3
		150

■ Standard dimensions

TOMBO™ No.		1133
Maximum O.D.	[mm]	
	1.0 t	φ 610
	1.5 t	φ 1250
	2.0 t	φ 1430
Standard thickness		
	1.0 t	●
	1.5 t	●
	2.0 t	●
		●

* The yellow part in the table can be made larger by welding.

Chemical resistance test

Test method: Measure the weight change rate of TOMBO™ No.1133 and our conventional gasket after leaving them immersed in representative acid and alkali fluid for 7 days each.

Fluid	Concentration	Temperature	TOMBO™ No.			
			1133	9007-SC	9007-LC	
Acid	Hydrochloric acid	35%	50°C	A	A	A
	Nitric acid	95%	100°C	A	A	A
	Sulfuric acid	65%	100°C	A	Measurement impossible ⁽¹⁾	A
	Hydrofluoric acid	55%	Room temperature	A	A	C
	Phosphoric acid	85%	100°C	A	A	A
Alkali	Sodium hydroxide	48%	100°C	A	A	C
	Potassium hydroxide	48%	100°C	A	A	B

Note: (1) The test was interrupted because the filler reacted with the fluid and emitted smoke.

A ...Good chemical resistance. B ...Study must be carried out using actual machine. C ...Cannot be used.

TOMBO™ No.1133 has excellent resistance to chemicals, including acids and alkalis.

■ Examples of chemicals for which CLINSIL™ Clean is suitable

Acids	Alkalis	Halogens	Aromatics	Others
Hydrochloric acid	Potassium hydroxide ⁽¹⁾	Chlorine gas	Benzene	Alcohols Dimethylform-amide
Sulfuric acid	Sodium hydroxide ⁽¹⁾	Bromine	Toluene	Hydrocarbons Tetrahydrofuran
Nitric acid	Liquid ammonia		Xylene	Organic acid Diethylamin
Acetic acid			Nathphalene	Vinyl acetate monomer Acetoaldehyde
Phosphoric acid ⁽¹⁾			Phenol	Styrene monomer Nitril liquid
Hydrofluoric acid			Cumene	Acrylonitrile Methyl chlorides
Formic acid				Saturated steam Etc.
Boric acid				Hexane

Note: (1) Fluids for which care is necessary

Under the following conditions, the filler may liquefy out and impair the performance of the gasket. For this reason, do not use this gasket under such conditions.

- For a sodium hydroxide water solution or potassium hydroxide water solution:
 - Fluid concentration is above 30% and fluid temperature is above 100°C
 - Fluid temperature is above 120°C

● In the case of phosphoric acid, when the temperature is at 100°C or higher.

● Chromic acid (hexavalent chrome)

* For other fluids, refer to the precautions for use.

Precautions for use are on P.24.

Gas seal test

Test method: Compress the gasket-sealed flanges filled with N₂ gas using a press, and measure the amount of leakage in terms of the reduction of pressure of the sealed gas.

[Test conditions]

- Gasket size: JIS 10K 50A FR (1.5t)
- Test jig: Platen that has the same dimensions as that used in JIS B 2490
- Tightening method: Press
- Seating stress: max. 34.3N/mm²
- Fluid: Nitrogen
- Internal pressure: 0.98MPa
- Leakage detection: Digital pressure gauge

[Test schematic drawing]

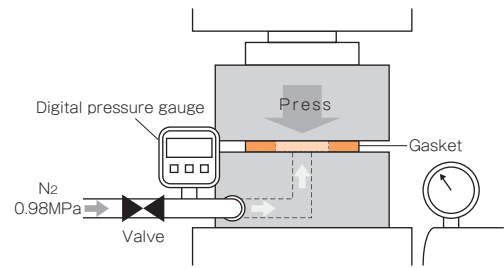

- ...TOMBO™ No.1133 (CLINSIL™ Clean)
- ...TOMBO™ No.9007-LC (NAFLON™ PTFE Low Creep cut gasket)
- △...TOMBO™ No.9007-SC (NAFLON™ special carbon filler filled PTFE cut gasket)
- Limit of leakage detection using soapy water foaming method (0.2ml/min)

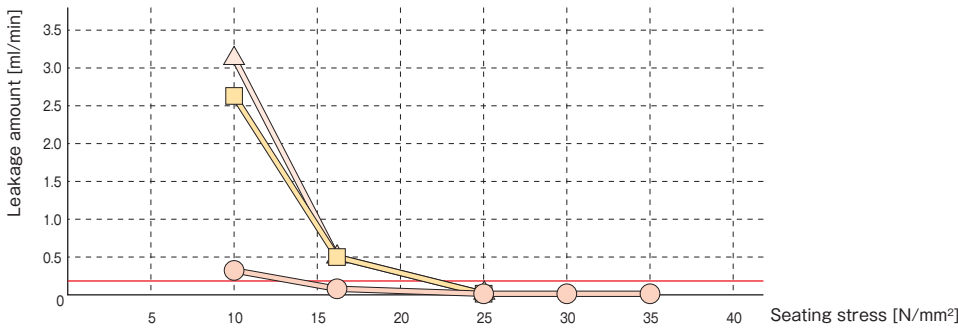

TOMBO™ No.1133 has excellent sealing performance, even when the seating stress is low.

Heat resistance test

Test method: Subject the gasket to a heat cycle under the following conditions, and carry out a sealing test for the specified number of cycles.

[Test conditions]

- Flange size: JIS 10K 25A RF
- Gasket thickness: 1.5mm
- Seating stress: 34.3N/mm²
- Heating conditions: 300°C × 15hr × 10 cycles
- Fluid: Nitrogen
- Internal pressure: 1.0MPa
- Sealing test method: Soapy water foaming method

[Test results]

Number of cycles	Leakage
0	None
1	None
3	None
5	None
10	None

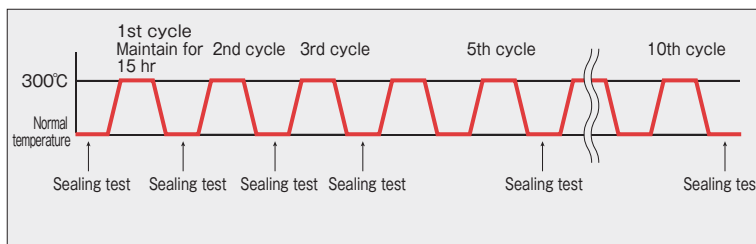

* Criterion for no leakage
Limit of detection using soapy water foaming method (0.2ml/min)

TOMBO™ No.1133 has excellent heat resistance.



Comparison of jointing sheets

TOMBO™ No.

1120

CLINSIL™ Top

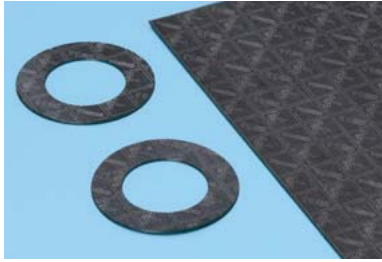

- Because the main constituent of this gasket is expanded graphite, it has excellent heat resistance, steam resistance, and corrosion resistance.
- Scratch resistant and flexible
- Can be used with relatively high temperature flanges, valves and equipment.

Main constituents: NBR, aramid fibers, expanded graphite

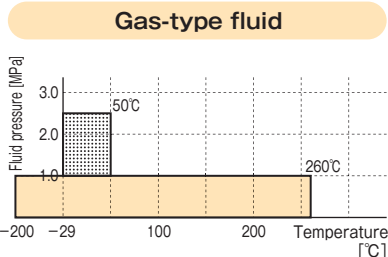
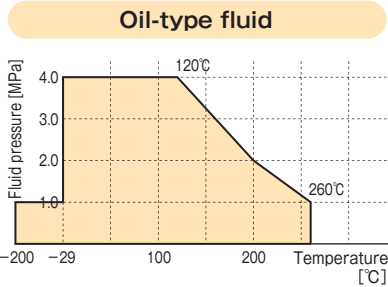
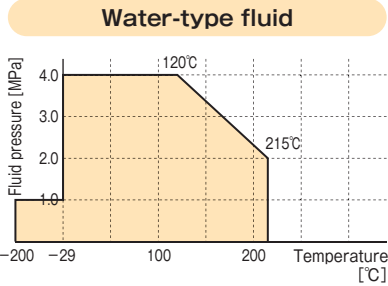

Regarding the shaded area, study it carefully before use.

TOMBO™ No. 1120-LN

This gasket is intended for use with low-temperature fluids, such as LNG. It is the TOMBO™ No.1120 which has been specially treated.

TOMBO™ No.

1995

CLINSIL™ Brown

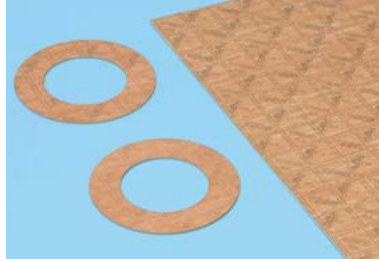

- Standard grade jointing sheet
- Large-size gasket available
Can be manufactured without joints to a maximum of 3810 x 3810mm (9S size).
- Can be used with relatively low temperature flanges, valves and equipment.

Main constituents: NBR, aramid fibers, inorganic fibers

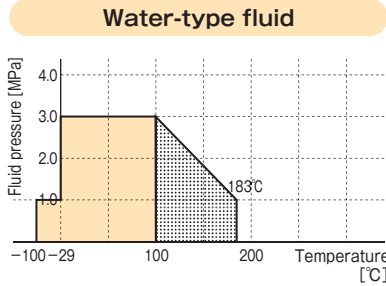

A rough guide to the service life of this gasket when it is used as a pipe gasket to seal steam of 100°C or higher is as follows.
▨ area: 1-2 years

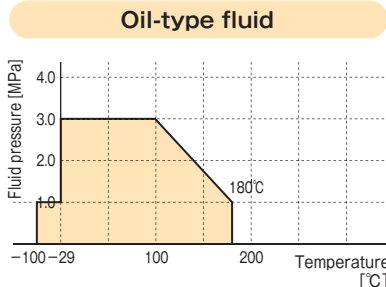

*Do not use this gasket with aromatic fluids.

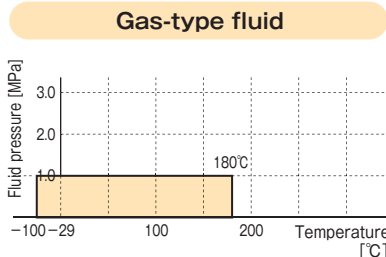

TOMBO™ No. 1995-W CLINSIL™ White

This is a white jointing sheet that has the same performance as the TOMBO™ No.1995.

TOMBO™ No.

1993

CLINSIL™ Super

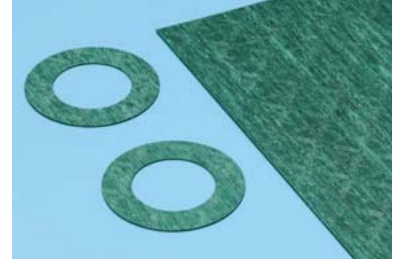

- This gasket has excellent heat resistance and steam resistance, making it suitable for use in a steam line.

Main constituents: Specially blended rubber, aramid fibers, inorganic filler

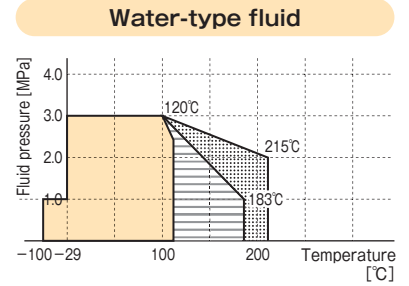

A rough guide to the service life of this gasket when it is used as a pipe gasket to seal steam of 100°C or higher is as follows.
▨ area: 5-10 years ▨ area: 1-2 years

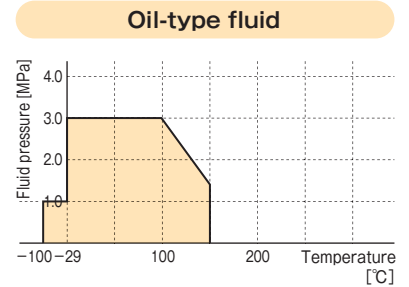

*Do not use this gasket with aromatic fluids.

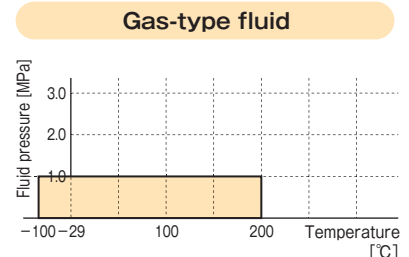

! Do not use TOMBO™ No.1993 for gas type fluids where even minute amounts of leakage are not allowed. Even for use with the water- or oil-type fluid, be sure to use paste when carrying out an airtightness test. It is recommended to use TOMBO™ No.1133 or TOMBO™ No.1120 instead.

A jointing sheet is a sheet gasket consisting of rubber, fibers and filler which are kneaded together and then rolled using a roller. It is formed to the necessary dimensions and shape, and used at joints of utility pipes and equipment.

TOMBO™ No.

1991-NF

CLINSIL™ NF

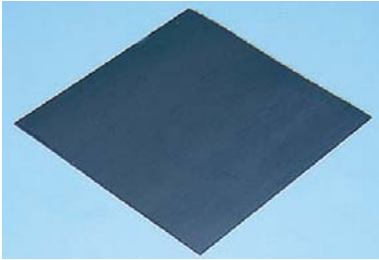

● This sheet is highly resistant to alternative CFCs. It is therefore suitable for equipment such as a chiller compressor that uses alternative CFCs (HCFC, HFC, etc.).

Main constituents: NBR, aramid fibers, special inorganic filler

Water-type and oil-type fluids

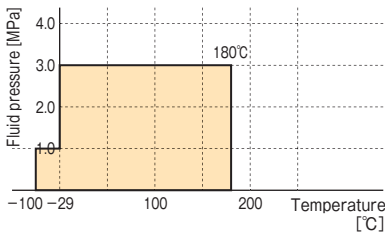

Gas-type fluid

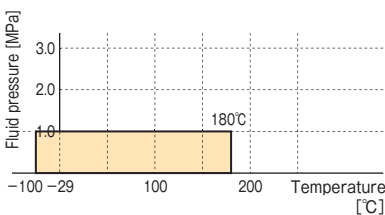

TOMBO™ No.

1938

CLINSIL™ UF

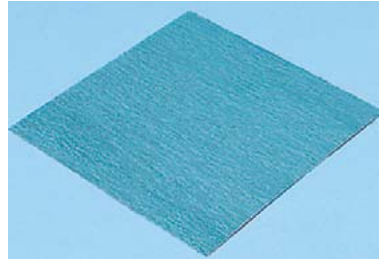

● This sheet has high tensile strength and shearing strength, and can be easily stamped into various shapes. It is suitable for union joints.

Main constituents: NBR, aramid fibers, inorganic filler

Water-type and oil-type fluids

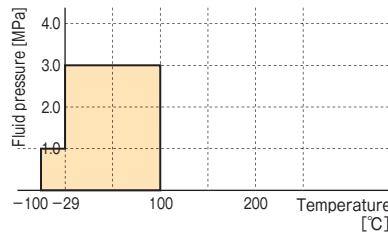

Gas-type fluid

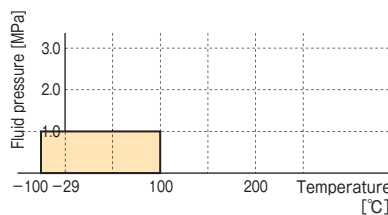

Product name

Features

Construction

Service range

* Be sure to read the precautions concerning gas-type fluids.

Jointing sheets

Details of design criteria, standard dimensions and basic physical characteristics P.18

Precautions when using a jointing sheet with a gas-type fluid P.19

Dimensional table P.68-77



Design criteria

TOMBO™ No.		1120	1995	1993	
Gasket coefficient m [-]	0.8 t	3.50			
	1.5 t	2.75			
	3.0 t	2.00			
Minimum design seating stress y [N/mm ²]	0.8 t	44.8			
	1.5 t	25.5			
	3.0 t	11.0			
Minimum seating stress σ_3 [N/mm ²]	Water-type and oil-type fluids	14.7			
	Gas-type fluids	34.3 ⁽¹⁾			
Allowable seating stress [N/mm ²]	Without paste	0.8 t	294.2		
		1.5 t	196.1		
		3.0 t	98.0	147.1	
	With paste	0.8 t	68.6 ⁽²⁾		
		1.5 t			
		3.0 t			

Note : (1) Use of gaskets with thickness of 3.0t for gas-type fluid is not recommended.
(2) 58.8N/mm² when anti-corrosion paste is used.

Standard dimensions

TOMBO™ No.		1120	1995	1993	1991-NF	1938
1S (1270×1270mm)	0.4 t	●	—	—	●	—
	0.5 t	●	—	●	●	—
	0.8 t	●	●	●	●	—
	1.0 t	●	●	●	●	●
	1.5 t	●	●	●	●	●
	2.0 t	●	●	●	—	●
	3.0 t	●	●	●	—	—
3S (1270×3810mm)	0.4 t	●	—	—	●	—
	0.5 t	●	—	●	●	—
	0.8 t	●	●	●	●	—
	1.0 t	●	●	●	●	—
	1.5 t	●	●	●	●	—
	2.0 t	●	●	●	—	—
	3.0 t	●	●	●	—	—
6S (2540×3810mm)	0.8 t	●	—	—	—	—
	1.0 t	●	●	—	—	—
	1.5 t	●	●	—	—	—
	2.0 t	●	●	—	—	—
	3.0 t	●	●	—	—	—
9S (3810×3810mm)	0.8 t	—	—	—	—	—
	1.0 t	—	—	—	—	—
	1.5 t	—	●	—	—	—
	2.0 t	—	●	—	—	—
	3.0 t	—	●	—	—	—
Weight [kg] per sheet of thickness 1.5t and 1S size (reference)		3.63	4.35	4.23	3.75	4.35

* The above are standard dimensions. We can also manufacture some sheets that are not marked ●. For details, please contact us.

Typical physical properties

TOMBO™ No.		1120	1995	1993	1991-NF	1938	
Sample thickness [mm]		1.5	1.5	1.5	1.0	1.5	
Tensile strength [N/mm ²]		27.5	24.1	14.7	26.2	21.6	
Compressibility [%]	34.3N/mm ²	9	7	7	6	7	
Recovery [%]		70	65	52	67	55	
Oil resistance	IRM903 oil 150°C×5h	Thickness increase ratio [%]	2	3	24	1	1
		Tensile strength reduction ratio [%]	11	23	33	-1	0
	IRM903 oil 40°C×48h	Thickness increase ratio [%]	—	4	—	1	—
		Tensile strength reduction ratio [%]	—	4	—	6	—
		Compression ratio [%]	—	6	—	6	—
		Recovery [%]	—	64	—	73	—
Resistance to fuel oil	ASTM Fuel B (JIS fuel oil B) R.T.×5h	Thickness increase ratio [%]	2	4	18	3	3
		Mass increase ratio [%]	1	6	17	5	4
Stress relaxation ratio [%] 100°C×22h		25	28	20	15	26	
Density [g/cm ³]		1.53	1.84	1.71	1.62	1.80	

* The above values are measured values. They are not standard values.

⚠️ Precautions concerning jointing sheets

■ Precautions concerning design and selection

● Finish of the gasket seat

The recommended surface roughness when using a jointing sheet is as follows.

- For sealing liquid : 6.3 μm Ra
- For sealing gas : 3.2 μm Ra

● Recommended thickness and shape of gasket

The recommended thickness and shape of jointing sheets are as follows.

Fluid	Nominal diameter	Thickness	Shape
Water-type and oil-type	150A (6B) max.	1.5mm	—
	200A (8B) min.	3.0mm	—
Gas-type	All sizes	1.5mm min. ⁽²⁾	Ring-shaped ⁽³⁾
Steam and hot water lines ⁽¹⁾	All sizes	1.5mm	Ring-shaped ⁽³⁾

Note: (1) Recommended when TOMBO™ No.1995 is used in a steam or hot water line at 100°C or higher or when TOMBO™ No.1993 is used in a steam or hot water line at 120°C. Use a VORTEX™ gasket or a kammprofile gasket in a location where maintenance is difficult to carry out.

(2) It is recommended that a thin gasket be used in order to suppress leakage due to penetration.

(3) In the case of an FF shape, if it is not possible to obtain an adequate seating stress, it is recommended that a ring shape in which the gasket is on the inside of the bolts be used.

⟨Gasket shape⟩

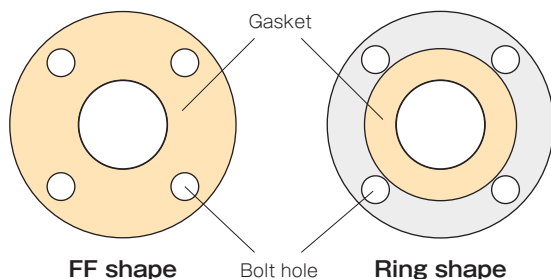

■ Precautions for use

● Using a jointing sheet with a gas-type fluid

A jointing sheet consists of fibers, filler and rubber which are kneaded together and then rolled. For this reason, it contains many voids. When using such a sheet with a gas-type fluid, penetration leakage is liable to occur, so pay attention to the following points.

- Apply gasket paste thinly and evenly to the seating surfaces and inner periphery.
- Apply sufficient seating stress.
- Before carrying out an airtightness test, install the gasket with paste applied and leave it for 2 to 3 hours to allow it to bond with the flange.
- **Do not use a jointing sheet as a seal for a toxic gas line or a high vacuum line where even a minute amount of leakage is not allowed.**

● Using a jointing sheet in a steam or hot water line

When using TOMBO™ No.1995 in a steam or hot water line at 100°C or higher, or when using TOMBO™ No.1993 in a steam or hot water line at 120°C, apply a seating stress of 29.4 N/mm² or higher and take care not to apply piping stress to the gasket.

● Using a jointing sheet between stainless steel flanges

Compared to an asbestos jointing sheet, a non-asbestos joint sheet contains only a small amount of soluble halogen, so it can also be used with stainless steel flanges as well. There is no need to use anti-corrosion paste.

● Additional tightening

- **When TOMBO™ No.1995 or TOMBO™ No.1993 is heated, the gasket will harden as time passes, preventing additional tightening from being performed.**
- TOMBO™ No.1120 can be additionally tightened, but the additional tightening at high temperature (hot bolting) cannot be performed as the allowable seating stress falls at high temperature.

● To prevent compressive breakage

To prevent compressive breakage of the joint sheet, strictly observe the following items.

Do not overtighten.

- **Do not tighten the gasket past the allowable seating stress.**
- Tighten the gasket evenly.
(If an uneven load is applied to the gasket as a result of uneven tightening, compressive breakage may occur even if the seating stress is within the allowable value. Particular care must be exercised so as not to tighten the gasket unevenly.)
- In the case of a small I.D. flange, a large tightening force is sometimes applied to the gasket, so be careful not to overtighten.

Precautions for using gasket paste

- Recommended gasket paste
TOMBO™ No.9105, 9106, or 9400
*Please consult us when using any paste other than the above.
- Gasket paste that must not be used
Do not use the following kinds of paste as they may cause compressive breakage below the allowable seating stress.
Solvent-type liquid packing (It may swell the gasket.)
Silicone-type oil or grease (It may increase the slipping of the gasket.)

Tightening gasket at high temperature (hot bolting)

Hot bolting may cause compressive breakage even below the allowable seating stress.

● The surface sometimes becomes white, but this has no effect on performance.

Applicable standards

- ASME B 16.21
"Nonmetallic Flat Gaskets for Pipe Flanges"
- JIS F 0602
"Shipbuilding - Non-asbestos gasket to cargo piping system - Application standard"
(HJ TOMBO™ No.1995, TOMBO™ No.1993, TOMBO™ No.1991-NF, TOMBO™ No.1938)
- JIS F 7102
"Standard for Using Gaskets and Packing for Pipes in Marine Engines"
(HJH TOMBO™ No.1995, HJT TOMBO™ No.1993)



Comparison of fluoropolymer gaskets

Recommended service range
Usable range (The usable range depends upon the conditions. Be sure to consult us in advance.)

TOMBO™ No.

1133

CLINSIL™ Clean



Conforms to the Standards and criteria for food and food additives, etc. (S.D.2: Public Notice No. 370 of the Ministry of Health & Welfare, 1959) stipulated by the Food Sanitation Act



- Can be used with a wide range of fluids including acids, alkalis, petroleum, petrochemical products, organic solvents, hot oil, heating medium gas, and steam. (Excluding some strong alkalis and strong acids.)
- Has the highest heat resistance of all fluororesin gaskets.
- Can also be used where electrical insulating performance is necessary.

Main constituents: PTFE, alumina

Water-type fluid

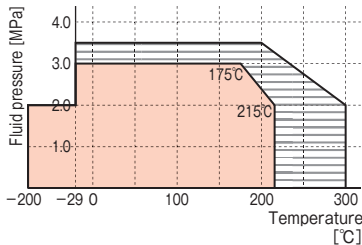

Oil-type or corrosive fluids

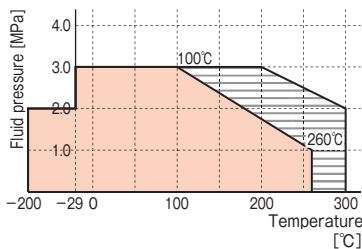

Gas-type fluid

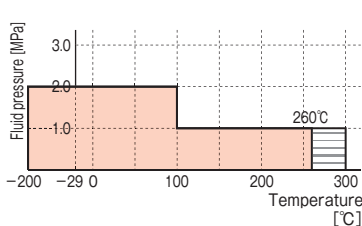

* The greater the thickness, the larger is the deformation due to creep. For this reason, it is recommended that you select a gasket of 1.5mm in thickness for a gas line which exceeds 200°C.

TOMBO™ No.

9007-SC

NAFLON™ special carbon filler filled PTFE cut gasket



- Can be used with strong alkaline fluids. (It cannot be used with nitric acid, concentrated sulfuric acid, chromic acid, or other oxidizing fluids.)

Main constituents: PTFE, carbon

Water-type, oil-type or corrosive fluids

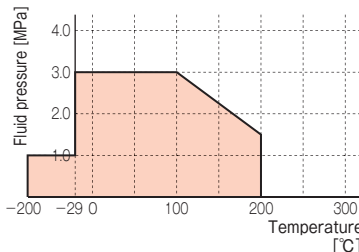

Gas-type fluid

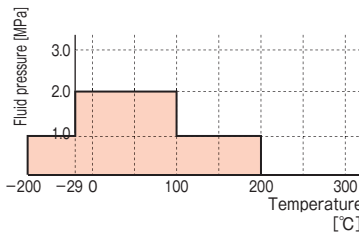

Information

Creep is a deformation that occurs after the lapse of a certain time after a material has been exposed to a certain temperature and stress. Creep at normal temperature is also called "cold flow".

TOMBO™ No.

9007-LC

NAFLON™ PTFE Low Creep cut gasket



- Can be used with strong acidic fluids. (It cannot be used with hydrofluoric acid or strong alkalis.)
- Can be used where electrical insulating performance is necessary.

Main constituents: PTFE, silica

Water-type, oil-type or corrosive fluids

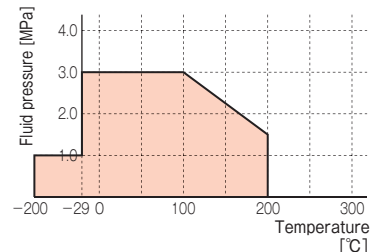

Gas-type fluid

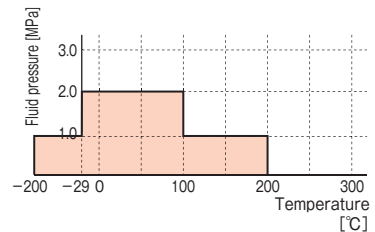

These gaskets are based on fluoropolymer which is excellent heat resistance and chemical resistance. A gasket that is blended with a filler, such as alumina, has reduced deformation because of the filler, so compared to a gasket that consists of PTFE alone, these gaskets do not creep even at high temperature.

TOMBO™ No.

9007-GL

NAFLON™ GL gasket



- This gasket is very flexible, so it is suitable for glass-lined pipes, plastic pipes, etc. where a large tightening torque cannot be applied.

Main constituents: PTFE, silica filler

Water-type, oil-type or corrosive fluids

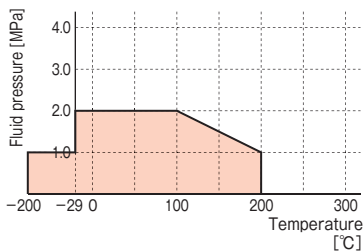

Gas-type fluid

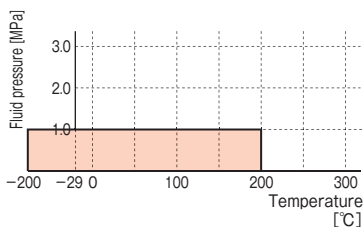

- When using TOMBO™ No.9007-GL or 9007-SGM in a gas-type fluid
- A ring-shaped (FR type) gasket is recommended (because the use of an FF type may fail to generate sufficient seating stress).
 - In order to improve the sealing performance, it is recommended that TOMBO™ No.9400 (NAFLON™ paste) be used as well.

TOMBO™ No.

9007-FD

NAFLON™ FD gasket



- This gasket is more flexible than TOMBO™ No.9007-GL.
- Because this gasket is porous, it is not suitable for a gas-type fluid.

Main constituents: PTFE, silica filler

Water-type, oil-type or corrosive fluids

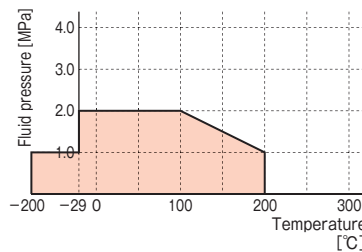

Gas-type fluid

TOMBO™ No.9007-FD is of a porous construction, so it is not recommended for use with a gas-type fluid.

TOMBO™ No.

9096-SGM

SGM™ gasket

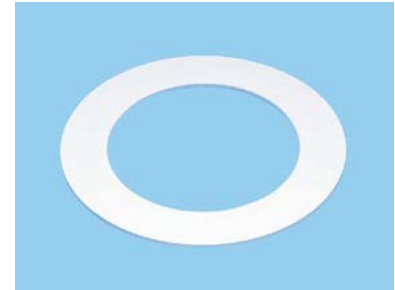

- This gasket is very flexible.
- Because it does not contain filler, it can be used in a line where contamination is not permitted.
- Can be used where electrical insulating performance is necessary.

Main constituents: Rolled PTFE

Water-type, oil-type or corrosive fluids

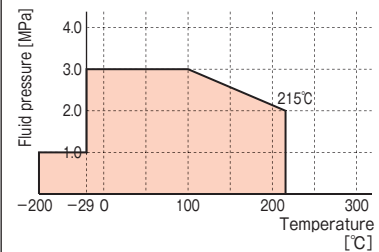

Gas-type fluid

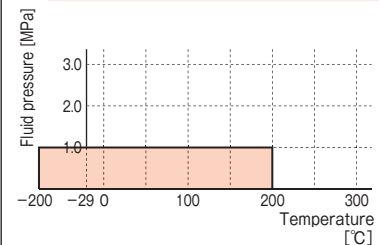

TOMBO™ No.9096-SGM

The application of these products are intended for general industrial use.

- Process under the GMP management
- Product to touch body tissues or body fluid
- Process to contact food or cosmetics directly

Product name

Features

Construction

Service range

Recommended service range

Line up

TOMBO™ No.

9007

NAFLON™ PTFE cut gasket

 Conforms to the Standards and criteria for food and food additives, etc. (3-D-2, Public Notice No. 370 of the Ministry of Health & Welfare, 1959) stipulated by the Food Sanitation Act

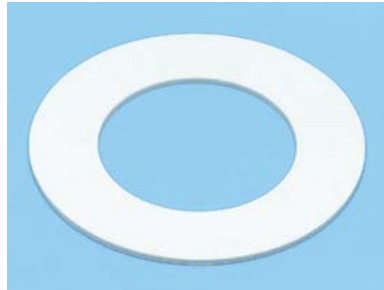

- This is a pure PTFE sheet, so it is suitable for use with fluids that are not permitted to become contaminated.
- This gasket is resistant to virtually all conceivable chemicals, but cannot be used at a temperature of 100°C or higher because deformation due to creep becomes large.

Main constituents: PTFE

* Compared to a gasket that contains a filler, this gasket is liable to creep. Use it with a grooved flange (T&G) as a general rule.

Water-type, oil-type or corrosive fluids

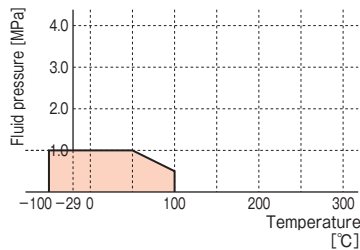

Gas-type fluid

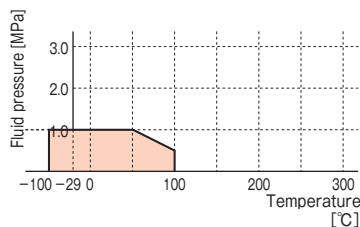

TOMBO™ No.9007-ST

Denatured PTFE gasket. Compared to TOMBO™ No.9007, this gasket has high creep resistance, so it can be used up to 150°C.

TOMBO™ No.

9007-ST

NAFLON™ ST cut gasket

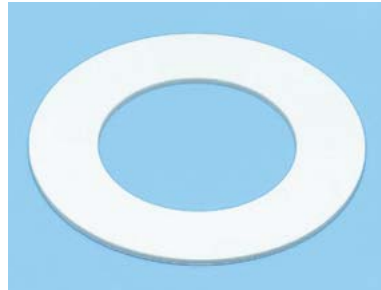

- The NAFLON™ ST cut gasket is made of modified PTFE, so creep resistance is high and therefore it can be used in higher temperatures compared to PTFE gaskets.
- It can also be used for liquids which are vulnerable to contamination.

Main constituents: Modified PTFE

Water-type, oil-type or corrosive fluids

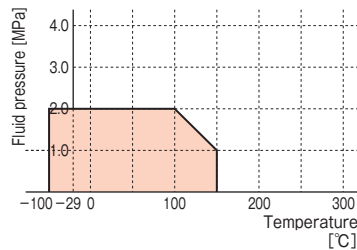

Gas-type fluid

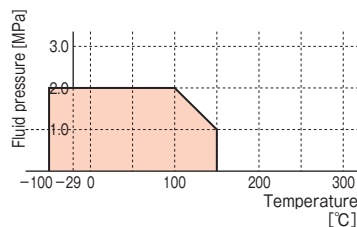

TOMBO™ No.

9007-ML

NAFLON™ ML cut gasket

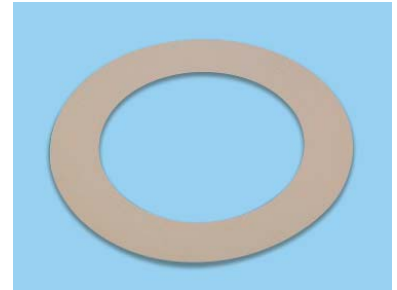

- This gasket is suitable for monomer lines.
- The gasket suppresses "blooming phenomena" that occur when monomer fluids leak and accumulate in the gaskets. The phenomena can cause volume expansion which destroys gaskets. As a result, this gasket has a stable seal characteristic which lasts for a long time.

Main constituents: Modified PTFE, Specially additive

Water-type, oil-type or corrosive fluids

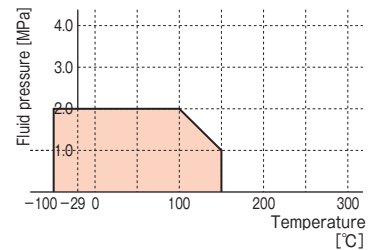

Gas-type fluid

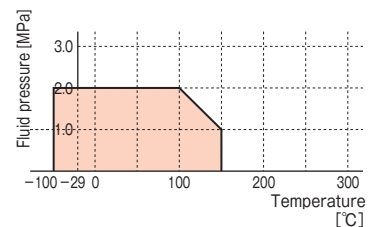

TOMBO™ No.

9007-LP

NAFLON™ LP gasket



- This gasket is less permeable than PTFE when used with a chemical liquid or gas. It is thus suitable for use with highly permeable halogen-based fluid, for example.

Main constituents: PFA

Water-type, oil-type or corrosive fluids

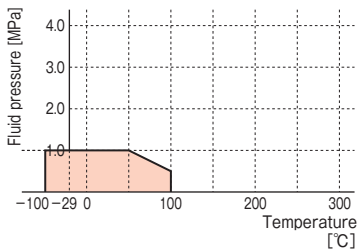

Gas-type fluid

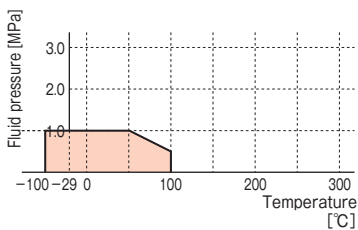

TOMBO™ No.

9007-G20

NAFLON™ glass fiber-filled PTFE cut gasket



- Standard PTFE gasket containing a filler.
- Cannot be used with hydrofluoric acid or strong alkali.

Main constituents: PTFE, glass fiber

Water-type, oil-type or corrosive fluids

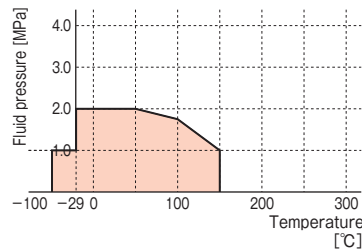

Gas-type fluid

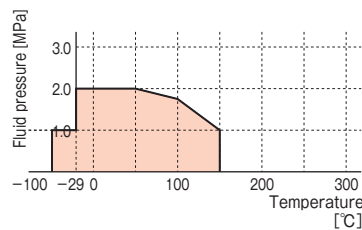

Product name

Features

Construction

Service range

Details of design criteria, standard dimensions and basic physical characteristics P.24



Design criteria

TOMBO™ No.		1133	9007-SC	9007-LC	9007-GL	9007-FD	9096-SGM	9007	9007-ST	9007-ML	9007-LP	9007-G20
Gasket coefficient m [—]	1.0 t	3.50	3.50	3.50	—	—	2.50	3.50	—	—	—	3.50
	1.5 t	2.75	3.20	3.20	—	—	2.50	3.20	3.20	3.20	—	3.20
	2.0 t	2.75	3.00	3.00	—	—	2.50	3.00	3.00	—	3.00	3.00
	3.0 t	2.00	2.50	2.50	2.50	2.50	2.50	2.50	2.50	2.50	—	2.50
Minimum design seating stress y [N/mm ²]	1.0 t	44.8	24.5	24.5	—	—	19.6	24.5	—	—	—	24.5
	1.5 t	25.5	22.5	22.5	—	—	19.6	22.5	22.5	22.5	—	22.5
	2.0 t	25.5	19.6	19.6	—	—	19.6	19.6	19.6	—	19.6	19.6
	3.0 t	11.0	19.6	19.6	19.6	19.6	19.6	19.6	19.6	19.6	—	19.6
Minimum seating stress σ_3 [N/mm ²]	Water-type or oil-type fluid	14.7	14.7	14.7	14.7	14.7	19.6	10.8	10.8	10.8	14.7	12.7
	Gas-type fluid	34.3	29.4	24.5	14.7	—	39.2	19.6 ⁽¹⁾ 14.7 ⁽²⁾	19.6 ⁽¹⁾ 14.7 ⁽²⁾	19.6 ⁽¹⁾ 14.7 ⁽²⁾	19.6	24.5 ⁽¹⁾ 19.6 ⁽²⁾
Allowable seating stress [N/mm ²]		150.0	58.8	49.0	39.2	39.2	117.6 ⁽³⁾	39.2	39.2	39.2	29.4	49.0

Note : (1) Minimum seating stress for a thickness of 1.0t or 1.5t.
 (2) Minimum seating stress for a thickness of 2.0t or 3.0t.
 (3) The allowable seating stress for a thickness of 2.0t or 3.0t is 78.4N/mm².

Standard dimensions

TOMBO™ No.		1133	9007-SC	9007-LC	9007-GL	9007-FD	9096-SGM	9007	9007-ST	9007-ML	9007-LP	9007-G20
Maximum O.D. [mm]	1.0 t	φ610	—	φ1200	—	—	φ1380	φ1200	φ1200	φ930	φ277	φ1200
	1.5 t	φ1250	φ1200									
	2.0 t	φ1250	φ1200	φ1200	—	—	—	—	—	—	—	—
	3.0 t	φ1430	φ1200	φ1430	φ600	φ1200	φ1380	—	—	φ930	—	—
Standard thickness	1.0 t	●	—	●	—	—	●	●	—	—	—	●
	1.5 t	●	●	●	—	—	●	●	●	●	—	●
	2.0 t	●	●	●	—	—	●	●	●	—	●	●
	3.0 t	●	●	●	●	●	●	●	●	●	—	●

* The yellow parts in the table indicate that the gaskets concerned can be manufactured to a larger bore than indicated, by carrying out welding work.
 * The green parts in the table indicate that the gaskets concerned can be manufactured to a larger bore than indicated, by carrying out bouding work.

Basic physical properties

TOMBO™ No.		1133	9007-SC	9007-LC	9007-GL	9007-FD	9096-SGM	9007	9007-ST	9007-ML	9007-LP	9007-G20
Thickness [mm]		1.5	1.5	1.5	3.0	3.0	1.5	1.5	1.5	1.5	2.0	1.5
Specific gravity [—]		2.74	2.06	2.30	1.94	1.62	1.83	2.18	2.17	2.18	2.18	2.21
Tensile strength [N/mm ²]		18	24	18	22	17	141	34	35	22	28	21
Compressibility [%]	34.3MPa	5	4	5	7	10	18	9	14	13	9	8
Recovery [%]		47	67	55	73	57	39	60	69	62	78	53
Stress relaxation ratio [%]	100°C × 22h	27	56	50	62	71	43	73	57	59	65	67
	200°C × 22h	59	79	74	87	90	67	—	—	—	—	—

* The above values are measured values. They are not standard values.

Precautions for fluoropolymer products

Precautions concerning design and selection

● Finish of the gasket seat

The recommended gasket seat when using a fluoropolymer gasket is as follows.

- For sealing liquid: 6.3 μm Ra
- For sealing gas: 3.2 μm Ra

Precautions for use

- Fluids for which a fluoropolymer gasket is not suitable.
 - Do not use a PTFE gasket with molten alkali metal, high-temperature fluorine, chlorine trifluoride or other fluid that corrodes PTFE.
 - When a fluororesin gasket is used with a monomer-based fluid, the fluid may permeate into the gasket, resulting in polymerization. In such a case, it is recommended it is recommended that you use a TOMBO™ No.9007-ML.
- Gas-type fluid
 - When using a fluoropolymer gasket to seal gas, use TOMBO™ No.9400 (NAFLON™ paste) together in order to improve the sealing performance.



TOMBO™ No. **4140 / 4140-NK**

SOFLEX™ / SOFLEX™-NK Punching products

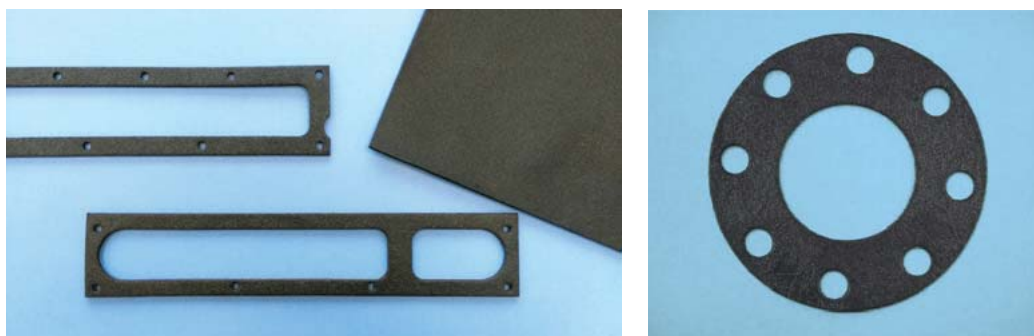

- SOFLEX™ is a black colored foam sheet. Fluoropolymer and various inorganic filler materials are mixed and molded together to create its sponge form.
- The compressibility is extremely high, so the fitting with the flange is good even with a low tightening. As a result, the seal characteristic of this product is high.
- Because the product is made of fluoropolymer, the chemical resistance is superb.

■ Lineup

The release paper of TOMBO™ No.4140-NK SOFLEX™-NK (type with adhesive for temporary fixing) adhesive can be easily peeled off, and the operability is excellent because of its dotted shape.

■ Applications

- Seal material for gas water heater
- Seal material for oil burning appliance
- As a heat insulating material

■ Standard dimensions

Nominal thickness	Dimension [mm]
1.0t	1,000×570
2.0t	
3.0t	

* With the cut processing, the product can be created in any shape.

■ Typical physical properties

		Measured value
Density	[g/cm ²]	0.40
Tensile strength	[MPa]	Longitudinal 1.1 Transverse 0.3
Compressibility [%]	Load 0.05N/mm ²	21.0
	Load 0.10N/mm ²	34.0
Thermal conductivity [W/m·k]	200°C	0.06
Maximum service temperature	[°C]	260

* The above values are measured values. They are not standard values.



TOMBO™ No. 9010-NA series

NAFLON™ PTFE envelope gasket

Precautions for use
P.29

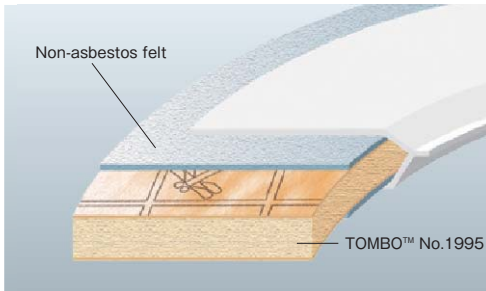

This is a PTFE envelope gasket consisting of a core made of a joint sheet, for example, covered with an outer PTFE skin. The sealing face is completely covered by a film of PTFE, providing resistance to contamination and also resistance to chemicals. This gasket is used in a wide variety of applications including fine chemicals, petrochemicals, pharmaceuticals, foodstuffs, and general industries.

■ Understanding a TOMBO™ No. When placing an order, specify the following product specifications (TOMBO™ No.).

TOMBO™ No. **9010** — **A** — **5** — **S** — **D**

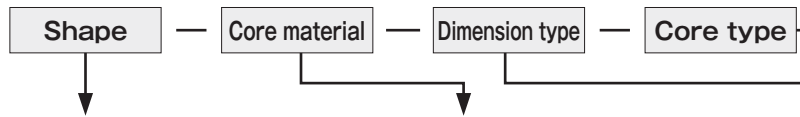

Shape	Indication symbol
	Standard type A
	Large bore type B
	Right-angled type AS
	Outside sewing type (Standard) KA
	Outside sewing type (Large bore) KB
	Outside sewing type (Right-angled type) KS
	Outside welded type (Standard) RA
	Outside welded type (Large bore) RB
	Outside welded type (Right-angled type) RS
Others	Z

Core material	Indication symbol
	TOMBO™ No. 1880-GR 2
	TOMBO™ No. 1993 3
	TOMBO™ No. 1995-W 4
	TOMBO™ No. 1995 5
	TOMBO™ No. 1995 6 Felt
	TOMBO™ No. 1120 7
	TOMBO™ No. 1120 8 Felt
	TOMBO™ No. 1120 9 SUS mesh
Others	Z

* A version of this product using rubber for the core is also available.

Core type	Indication symbol
	Single No symbol
	With handle H
	Double D
	Corrugated metal insert C
	Flat metal insert P
	Others Z

* When core material 6 or 8 is used in the double, corrugated or plate core structure, attach the felt only to the top and bottom surfaces.

Dimension type	Indication symbol
Standard dimension	S
Standard dimension of NAFLON™ lining ⁽¹⁾	F
Standard dimension of glass lining ⁽²⁾	G
Standard dimension of insulation gasket	E
Indicated dimension	Z

Note : (1) Nichias standard. Refer to the dimensions table for details.
 (2) Applicable to the GL flange from AGC Technology Solutions, Co., Ltd.

Service range

- Core material : CMGC (For high temperature)
TOMBO™ No.1880-GR

Thickness of core : 1.6t, 3.2t

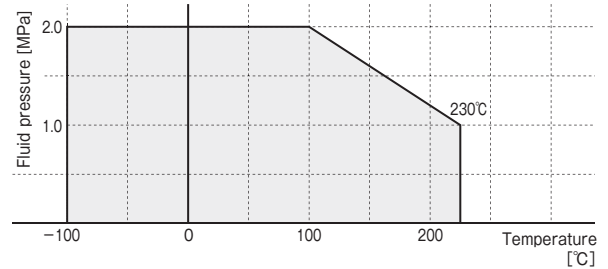

- Core material : Jointing sheet with SUS mesh
TOMBO™ No.1120+SUS mesh

Thickness of core : 2.5t

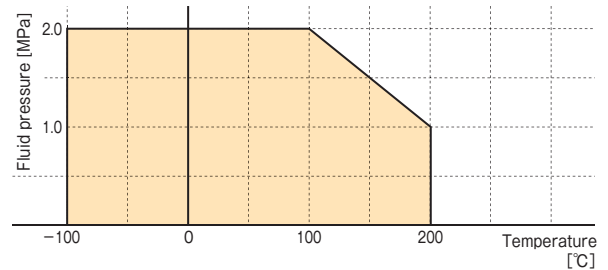

- Core material : Jointing sheet, Jointing sheet with felt
TOMBO™ No.1993/1995-W/1995/1995+Felt/1120/1120+Felt

* The service range of the gasket containing corrugated plate is limited to the shaded area.

Thickness of core : ~3.0t⁽³⁾

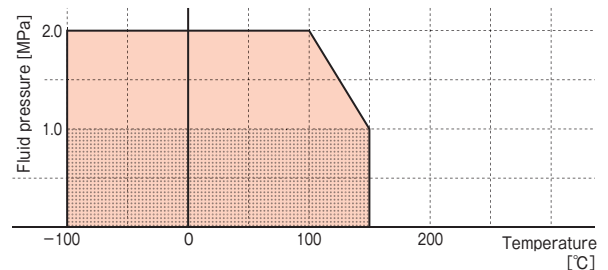

Thickness of core : ~4.0t

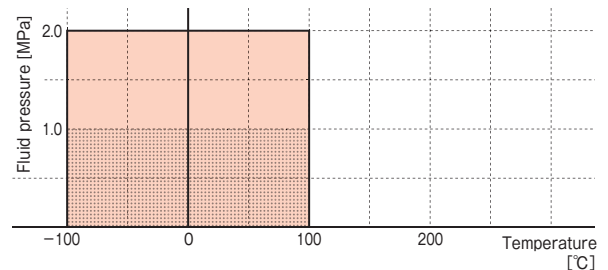

Thickness of core : ~6.0t

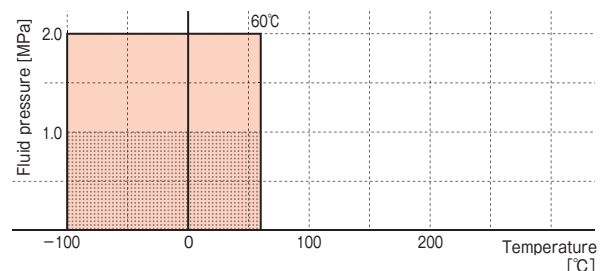

* Contact Nichias for information on other materials used for the core.
 Note : (3) Can be used in this range when the core material is 4.2t [1995 + Felt] or 4.2t [1120 + Felt].



Examples of TOMBO™ No.

9010-A-5-S	Shape Standard type	Core material TOMBO™ No.1995	Dimension type Standard dimension	
9010-A-5-F	Shape Standard type	Core material TOMBO™ No.1995	Dimension type Standard dimension of NAFLON™ lining	
9010-AS-5-G-C	Shape Right-angled type	Core material TOMBO™ No.1995	Dimension type Standard dimension of glass lining	Core type Corrugated metal insert
9010-B-2-Z	Shape Large bore type	Core material TOMBO™ No.1880-GR	Dimension type Indicated dimension	

[Comparison of old and new TOMBO™ No.]

New	Old
9010-A-5-S	9010-NA-A-5
9010-A-5-F	9010-NA-FG-5 (Type A)
9010-RS-7-S	9010-NA-R-AS-7 (Type AS)

Design criteria

Shape (Indication symbol)	Type A / AS / KA / KS / RA / RS		Type B / KB / RB	
Core materials [TOMBO™ No.]	1993 1995-W 1995 1995+Felt 1120 1120+Felt	1880-GR 1120+SUS mesh	1993 1995-W 1995 1995+Felt 1120 1120+Felt	1880-GR
Gasket coefficient m [-]	3.50	3.50	4.00	4.00
Minimum design seating stress γ [N/mm ²]	14.7	19.6	19.6	19.6
Minimum seating stress σ^3 [N/mm ²]	Water-type or oil-type fluids	9.8	14.7	14.7
	Gas-type fluid	14.7	19.6	19.6
Allowable seating stress [N/mm ²]	29.4	24.5 (39.2) ⁽¹⁾	29.4	24.5

Note : (1) The value in the brackets is for the 1120+SUS mesh type.

Standard dimensions

Shape	Type A / KA / RA	Type B / KB / RB	Type AS / KS / RS
Minimum I.D. [mm]	ϕ 15	ϕ 300	ϕ 20
Maximum O.D. [mm]	ϕ 1000 ⁽¹⁾	Arbitrary ⁽¹⁾	ϕ 700 ⁽¹⁾

Note : (1) Contact Nichias for information on the maximum outer dimensions of the welded outer periphery type.

⚠ Precautions for NAFLON™ PTFE envelope gaskets

■ Precautions concerning design and selection

● Tightening torque control

The gasket factor m , the minimum design seating stress y and the minimum required seating stress σ_3 of NAFLON™ PTFE envelope gaskets are designed assuming the following gasket seat finishes:

- Liquid sealing: $6.3\mu\text{m}$ Ra or less
- Gas sealing: $3.2\mu\text{m}$ Ra or less

Tightening torque greater than the design values may be required if the gasket seating surface is uneven or distorted.

In such cases, stringently control tightening torque since the maximum allowable seating stress of NAFLON™ PTFE envelope gaskets is low.

● Outer skin shape (inner periphery)

NAFLON™ PTFE envelope gaskets with the type A (basic type) outer skin shape may cause liquid accumulation. The type AS (right-angled type) outer skin is recommended in places where liquid accumulation should be avoided.

● Outer skin shape (outer periphery)

NAFLON™ PTFE envelope gaskets with types A, B and AS may suffer low gasket performance in the following circumstances:

- If operated under vacuum pressure
- If forcibly installed with insufficient distance between flange faces

If such circumstances are expected, we recommended using types which have the outer periphery of the outer skin sewn (KA, KB and KA) or welded (RA, RB and RS).

■ Precautions for use

PTFE envelope gaskets can be used for a wide range of applications, but there is possibility difficulties occurring in the following cases. It is recommended that you use a fluoro resin gasket such as the TOMBO™ No.1133 or TOMBO™ No.9007 series, as much as possible.

Case	Assumed phenomenon	Remedy
Used with a permeable fluid Nitric acid, ethylene oxide, halogens (chlorine, bromine, etc.), molten sulfur, monochloroacetic acid.	During long-term use, the fluid may permeate into the gasket through the PTFE covering material, damaging the core material and causing the gasket to lose its function.	<ul style="list-style-type: none"> ● Replace the gasket at shorter intervals. ● Use a PTFE cut gasket.
Gasket with core material of jointing sheet + felt is used.	If the core material is wet by a fluid, the compression breakage strength will fall. If soapy water or rainwater penetrates the gasket, causing the felt to soften and be pushed outward, the seating stress of the gasket may fall, resulting in possible leakage.	<ul style="list-style-type: none"> ● Store the gasket in a waterproof pouch or similar. ● After installing the gasket, take care that there is no ingress of rainwater. ● Ensure that the tightening force is sufficient.
Air bubbles were found between the PTFE outer skin and the core material when an airtightness test was performed.	Air included in the core material and also air stagnating on the inner periphery side has been discharged.	<ul style="list-style-type: none"> ● Wait for a certain time after applying the internal pressure load before carrying out an airtightness test. * This phenomenon is particularly liable to occur in the case of a gasket that has felt core material.
Rubber is used for the core material of the gasket.	Excessive deformation or air trapped in the inner periphery may compress the outer skin, causing damage.	<ul style="list-style-type: none"> ● Tighten to a torque below the maximum allowable seating stress.
Tightening torque is insufficient.	Due to the small difference between the minimum recommended tightening torque and the allowable tightening torque, even if the gasket is tightened to the target torque, the gasket contact pressure may be insufficient, causing leakage. (In particular, because large diameter types have a heat sealing section, their sealing performance is lower than that of basic and right-angled types.)	<ul style="list-style-type: none"> ● Use TOMBO™ No.9400 (NAFLON™ paste).
Gasket of standard dimensions is used on lined piping.	Liquid accumulation or leakage may occur due to different inside diameters.	<ul style="list-style-type: none"> ● Use a NAFLON™ lining of standard dimensions (applicable dimension symbol: F). ● Use a glass lining of standard dimensions (applicable dimension symbol: G). ● Design the appropriate gasket dimensions.



TOMBO™ No. 9096series

NICHIAS SOFT SEAL™



Conforms to the Standards and criteria for food and food additives, etc.

(3-D-2, Public Notice No. 370 of the Ministry of Health & Welfare, 1959) stipulated by the Food Sanitation Act
* Gaskets both with and without adhesive tape conform to the above.

Precautions for use

P.23

This is a PTFE soft type gasket. It is extremely soft, and the version with adhesive tape can be easily installed on sealing faces that are of complicated shapes. It is suitable as a piping sealant, or as a gasket for tanks, casings, ducts, pressure vessels, reaction tanks, lined containers, large bore equipment, and other applications.

■ **Understanding TOMBO™ No.** When placing an order, specify the following product specifications (TOMBO™ No.).

TOMBO™ No. **9096** — **R** — **10**

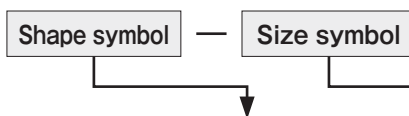

Shape	Shape symbol	Size			Size symbol
		Width [mm]	Thickness [mm]	Standard length/roll [m]	
Elliptical	No shape symbol	3.0	1.5	30	3
		6.0	3.0	15	6
		9.0	4.5	8	9
Not available without adhesive tape		12.0	6.0	5	12



Shape	Shape symbol	Size		Size symbol
		Width [mm]	Standard length/roll [m]	
Round	R	10.0	5	10
		12.0	5	12
Not available without adhesive tape				



Shape	Shape symbol	Size			Size symbol
		Width [mm]	Thickness [mm]	Standard length/roll [m]	
Tube	TB	2.0	1.0	30	21
		3.0	2.0	30	32
		4.0	3.0	30	43
		5.0	4.0	20	54
		6.0	5.0	20	65
		7.0	6.0	20	76
		8.0	7.0	10	87
		10.0	8.0	10	108
Not available without adhesive tape		12.0	10.0	10	1210



Shape	Shape symbol	Size		Size symbol
		Width [mm]	Thickness [mm]	
Sheet	ST (with adhesive tape)	1500 × 1500	1.0	1.0
			1.5	1.5
			2.0	2.0
			3.0	3.0
			4.0	4.0
			0.5	0.5
			1.0	1.0
	S (without adhesive tape)	1500 × 1500 1500 × 3000	1.5	1.5
			2.0	2.0
			3.0	3.0
			4.0	4.0
			5.0	5.0⁽¹⁾
			6.5	6.5⁽¹⁾
			10.0	10.0

⊘ TOMBO™ No.9096-S, ST, G, GT

The application of these products are intended for general industrial use.

- Process under the GMP management
- Product to touch body tissues or body fluid
- Process to contact food or cosmetics directly

Note : (1) Not available in 1500 × 3000 size.

Examples of TOMBO™ No.

9096-03	Shape: Elliptical	Size: Width 3mm, Thickness 1.5mm
9096-ST-1.0	Shape: Sheet (with adhesive tape)	Size: Width 1500×1500mm, Thickness 1.0mm
9096-TB-21	Shape: Tubular	Size: O.D. 2.0mm, I.D. 1.0mm
9096-B-1020	Shape: Flat (without adhesive tape)	Size: Width 20mm, Thickness 1.0mm
9096-G	Shape: Cut gasket (without adhesive tape)	Size: Please specify.

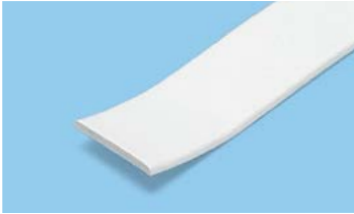

Shape	Shape symbol	Size			Size symbol
		Width [mm]	Thickness [mm]	Standard length/roll [m]	
Flat	BT (with adhesive tape)	20.0	1.0	15	1020
		30.0	1.0	15	1030
		50.0	1.0	15	1050
		100.0	1.0	15	1100
		20.0	2.0	5	2020
	B (without adhesive tape)	30.0	2.0	5	2030
		50.0	2.0	5	2050
		20.0	3.0	5	3020
		30.0	3.0	5	3030
		50.0	3.0	5	3050
100.0	3.0	5	3100		



Shape	Shape symbol	Size			Size symbol
		Width [mm]	Thickness [mm]	Standard length/roll [m]	
Square	KT (with adhesive tape)	14.0	5.0	10	5014
	K (without adhesive tape)	20.0	7.0	5	7020



Shape	Shape symbol	Remarks
Cut gasket	GT (with adhesive tape)	Gaskets for JIS and JPI piping are cut from soft seal sheets.
	G (without adhesive tape)	For other dimensions, please consult us.

Scope of use

Shape		Elliptical	Sheet
Temperature	[°C]	-100~260 ⁽¹⁾	
Pressure	Liquid	5	
	Gas	2	

Note : (1) Use below 200 deg C when the gasket is used for flange.

Design criteria

Shape	Elliptical				Sheet
	3mm	6mm	9mm	12mm	
Minimum seating stress	[N/mm]	75	100	125	150
Minimum design seating stress	[N/mm ²]	-			15~20

Compression Characteristics

Relationship of gasket thickness and width to tightening torque (Oval shaped sample)

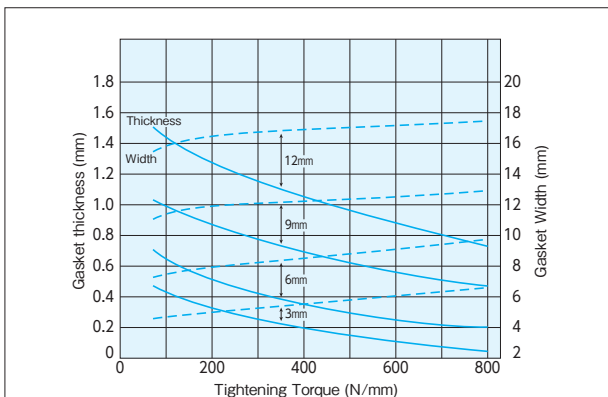

※The above figures show only measured values, these are not standard values.

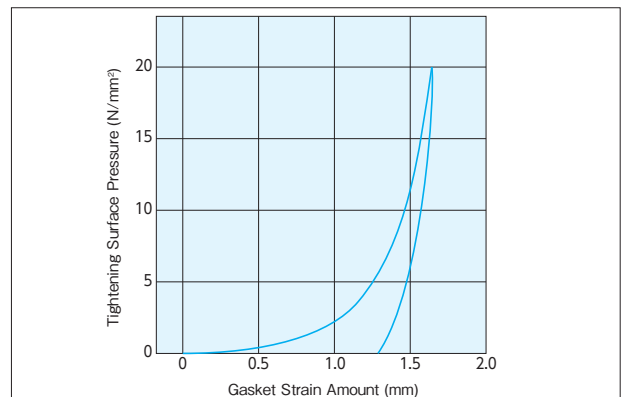

Compression recovery curve (Sheet thickness: 2mm)



※The above figures show only measured values, these are not standard values.

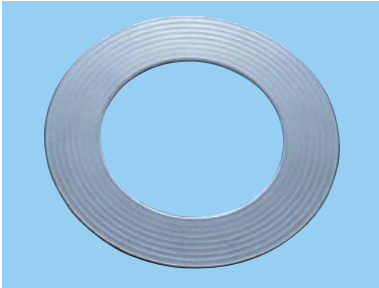
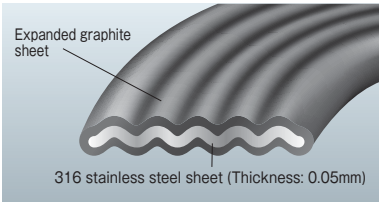

Comparison of **GRASEAL™** Gaskets

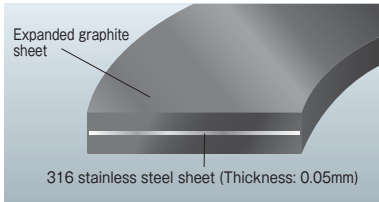
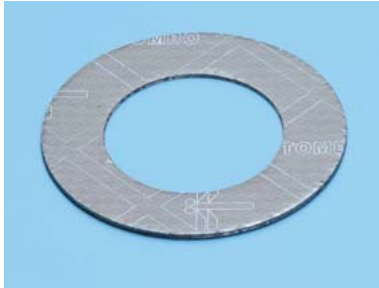
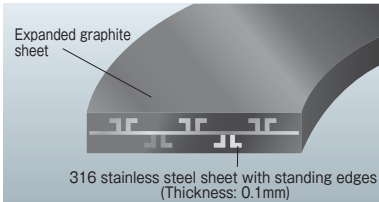
Product name	TOMBO™ No. 1880-GR CMGC gasket	TOMBO™ No. 1215-A GRASEAL™ gasket PM-A	TOMBO™ No. 1210-A GRASEAL™ gasket MI-A
Construction	 	 	 
Features	<ul style="list-style-type: none"> ● Gasket that is corrugated to concentrate the contact pressure, thus improving the sealing performance. ● Can also be formed into special shapes such as picture frame and flat face. ● Used with specially shaped flanges, valve bonnets, heat exchangers, etc. 	<ul style="list-style-type: none"> ● Has excellent handling ability, and can be formed into complicated shapes. ● Used with specially shaped flanges, valve bonnets, heat exchangers, etc. 	<ul style="list-style-type: none"> ● Has higher strength than TOMBO™ No.1215-A. <p>*This type is recommended in the case where the strength of TOMBO™ No.1215-A is insufficient, or when there is a limitation imposed by the specifications.</p>
Service range	<p>Service temperature</p> <p>Oxidising atmosphere -240~400℃</p> <p>Non-oxidising atmosphere -240~800℃</p> <p>Service pressure ~5.2MPa</p>	<p>Service temperature</p> <p>Oxidising atmosphere -240~400℃</p> <p>Non-oxidising atmosphere -240~800℃</p> <p>Service pressure ~5.2MPa</p>	<p>Service temperature</p> <p>Oxidising atmosphere -240~400℃</p> <p>Non-oxidising atmosphere -240~800℃</p> <p>Service pressure ~5.2MPa</p>
Remarks		<p>[Other lineups]</p> <p>A type with SUS304 steel sheet core is available. Its heat resistance and pressure resistance are not significantly different from those of TOMBO™ No.1215-A, so select a gasket that matches your specifications.</p> <ul style="list-style-type: none"> ·TOMBO™ No.1215 ... SUS304 with a thickness of 0.1mm ·TOMBO™ No.1215-B-E04 ... SUS304 with a thickness of 0.4mm ·TOMBO™ No.1215-B-E10 ... SUS304 with a thickness of 1.0mm <p>[Impermeability treatment]</p> <p>The TOMBO™ No.1215 series contains a lineup that has been treated to make it impermeable.</p> <ul style="list-style-type: none"> ·TOMBO™ No.1215-T ·TOMBO™ No.1215-AT ·TOMBO™ No.1215-BT-E04 ·TOMBO™ No.1215-BT-E10 	

▶ **Information**

Oxidising atmosphere: This refers to the state in which a gas contains a large quantity of oxygen, ozone, nitrogen dioxide or other oxidized gas. "Ambient atmosphere" corresponds to an oxide atmosphere.

Non-oxidising atmosphere: This refers to a state in which a space is filled with a noble gas, nitrogen, nitrogen dioxide, or the like.

Impermeability treatment: Expanded graphite is graphite that has been expanded between the crystalline layers. It has a porous construction, so a GRASEAL™ gasket is unable to completely prevent minute amounts of gas leakage. If high gas sealing performance is demanded, use a gasket that has been subjected to impermeability treatment and to which sufficient seating stress for sealing can be applied.

When impermeability treatment is carried out, the heat resistance will fall (maximum service temperature: 260℃), but the gas sealing performance will improve.

GRASEAL™ gasket is a cut gasket made from expanded graphite sheet or an expanded graphite sheet containing a metallic reinforcing plate.

TOMBO™ No.

1200

GRASEAL™ gasket

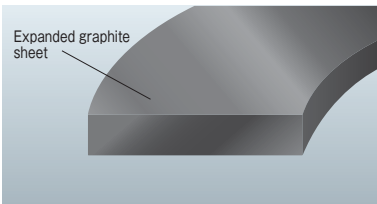
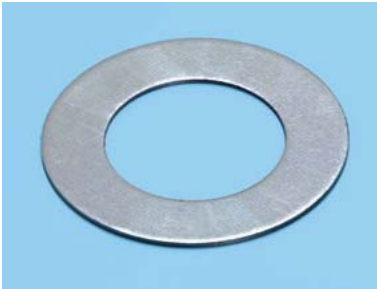

- More economical than other GRASEAL™ gaskets.
- This gasket has lower strength and poor handling compared to a gasket containing a steel plate. For this reason, it should be used only for a nominal diameter of 4 inches or less.

Service temperature

Oxidising atmosphere -240~400°C

Non-oxidising atmosphere -240~800°C

Service pressure

~3.0MPa

TOMBO™ No.

1220/1221

GRASEAL™ gasket tape (Plane/Crinkle)

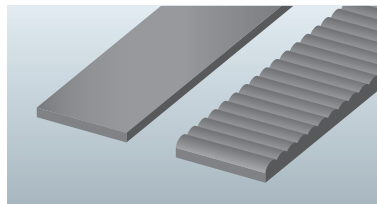

- Can be directly applied to the flange face as a free size gasket.
- Can be bonded to a hard gasket (TOMBO™ No.1850 or 1841) as an auxiliary sealing material.

*Do not apply this tape to a soft gasket such as a jointing sheet.

Service temperature

Oxidising atmosphere -240~400°C

Non-oxidising atmosphere -240~800°C

Service pressure

~3.0MPa

[Examples of use]

- TOMBO™ No.1220, 0.13mm in thickness
As a sealant tape for a high temperature screw coupling
(Maximum service temperature: 300°C)
- TOMBO™ No.1220, 0.25mm in thickness
As a seal for a flange of 18 inches or larger bore
- TOMBO™ No.1221
As a seal for a flange of 16 inches or smaller

Product name

Construction

Features

Service range

Remarks

Details of design criteria, standard dimensions, and precautions **P.34**

Dimension table **P.68 - 77**



■ Design criteria

TOMBO™ No.		1880-GR	1215-A	1210-A	1200
Gasket coefficient m	[-]	2.00	2.00	2.00	2.00
Minimum design seating stress y	[N/mm ²]	26.0	29.4	29.4	26.0
Minimum seating stress σ_3	Water-type or oil-type fluid	14.7	14.7	14.7	14.7
	Gas-type fluid ⁽¹⁾	39.2	49.0	49.0	49.0
Allowable seating stress	0.8 t	—	294.0	294.0	170.0
	1.6 t	166.0	167.0	167.0	106.0
	3.2 t	166.0	98.0	98.0	79.0

Note : (1) There may be cases that it is difficult to obtain the required seating stress by the standard dimension gaskets.

■ Standard dimensions

TOMBO™ No.	1880-GR	1215 1215-T	1215-A 1215-AT	1215-B-E04 1215-BT-E04	1215-B-E10 1215-BT-E10	1210-A	1200
Nominal thickness [mm]	1.6, 3.2	0.8, 1.6, 3.2	0.8, 1.6, 3.0	1.2, 2.0	1.8, 2.6	1.5, 2.0, 3.0	0.4, 0.8, 1.6, 3.2
Reinforcing plate thickness [mm]	0.8	0.10	0.05	0.40	1.00	0.10	—
Diameter of gasket that can be manufactured [mm]	φ3300 ⁽¹⁾	φ580	φ1480 ⁽³⁾	φ985 ⁽²⁾	φ985 ⁽²⁾	φ1480	φ985
Minimum width [mm]	12.8	10	5	10	10	—	—

Note : (1) For a dimension exceeding φ3300mm, please consult us.

(2) If the O.D. of the gasket exceeds φ985mm, weld a stainless steel sheet of 1.0mm thickness at several locations, or bond an expanded graphite sheet at several locations. [maximum O.D. φ2800mm, minimum width 40mm]

(3) A gasket with a nominal thickness of 0.8mm can be manufactured to a maximum diameter of φ985mm.

[GRASEAL™ tape]

TOMBO™ No.	1220			1221	
Thickness [mm]	0.13	0.25	0.25	0.38	0.38
Width [mm]	12.7	12.7	25.4	12.7	25.4
Length [mm]	7.6	7.6	15.2	7.2	14.2

⚠ Precautions concerning GRASEAL™ gaskets

■ Precautions concerning design and selection

● Finish of the gasket seat

The recommended gasket seat surface roughness when using a GRASEAL™ gasket is as follows.

- For sealing liquid: 6.3μm Ra max.
- For sealing gas: 3.2μm Ra max.

● Dimension of the gasket

When a GRASEAL™ gasket is used to seal the gas-type fluid, care should be taken that it is difficult to obtain the required seating stress (σ_3 or the like) by the gasket of the standard dimension.

■ Precautions for use

An expanded graphite gasket is liable to deform or become damaged, so be very careful when handling it. If the gasket surface is deformed or greatly damaged, it may be impossible to maintain its intrinsic performance.

- Do not place a heavy object on the gasket.
- Do not strike the gasket with a hard object.
- Do not step on the gasket or bend it with your foot.
- When using a cutter or other sharp implement to unpack the gasket, take care not to damage the gasket.
- Do not pull out the gasket until you have completely unpacked it.

Fluids for which a GRASEAL™ gasket is not suitable.

Classification	Name of fluid
Oxidizing acid	Nitric acid, concentrated sulfuric acid, hot sulfuric acid, chromic acid, mixed acid, etc.
Oxidizing salt	Nitrate, chloride, hypochlorite, etc.
Halogen compound	Bromine, fluorine, iodine, chlorine dioxide, etc.
Combustible gas	Oxygen (pure oxygen)

● When handling TOMBO™ No.1210-A, TOMBO™ No.1215 series, be careful not to cut your finger with metallic plate.

● When using TOMBO™ No.1210-A, TOMBO™ No.1215 series, please confirm that 316 stainless steel is resistant to the fluid.

Applicable standards (TOMBO™ No.1200, 1210, 1215 series)

■ JPI-7S-79

"Expanded Graphite Sheet Gasket for Piping"

■ JIS F 7102

"Standard for Using Gaskets and Packing for Pipes in Marine Engines"



Semi-metallic gasket

A semi-metallic gasket consists of a combination of a metal, such as a stainless steel sheet, and a non-metal, such as expanded graphite. It can be used at higher temperature and pressure than a soft gasket. Nichias offers the following semi-metallic gaskets.

For details of kammprofile gaskets, see P.36, P.39 and P.40.

For details of VORTEX™ gaskets, see P.36 to 38, and P.42 to 49.

For details of metal jacket gaskets, see P.38, P.50 and P.51.

Kammprofile gaskets

〈Standard type〉

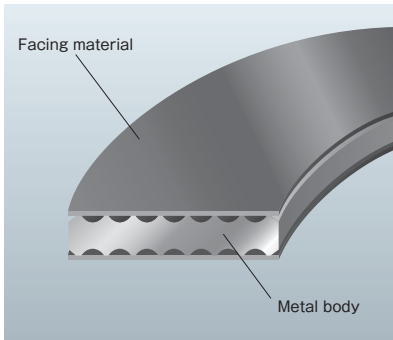

〈Outer ring type〉

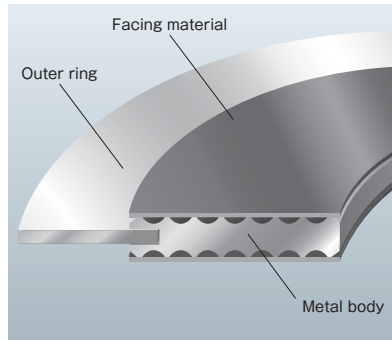

A kammprofile gasket is a semi-metallic gasket consisting of an expanded graphite sheet or a PTFE sheet bonded to both faces of a metal ring that has a special groove cut in it. It features a construction in which the convex surface has been flattened so as to greatly reduce damage to the flange.

VORTEX™ gaskets

〈Basic type〉

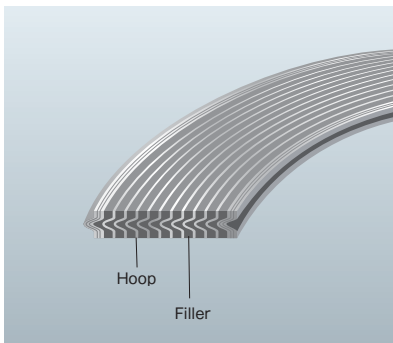

〈Inner and outer ring type〉

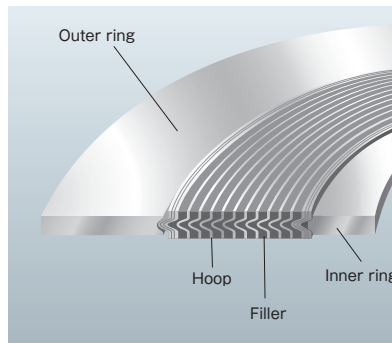

A VORTEX™ gasket consists of alternate layers of thin V-shaped metal band plates called hoops and cushion material called filler, wound in the shape of a vortex. There is also a type that has metal reinforcing material (inner and outer rings). When using this type of gasket, it is necessary to select an appropriate shape according to the type of flange to be used.

Metal jacketed gaskets

〈Normal type〉

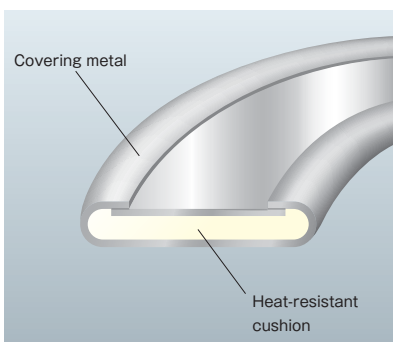

〈Corrugated type〉

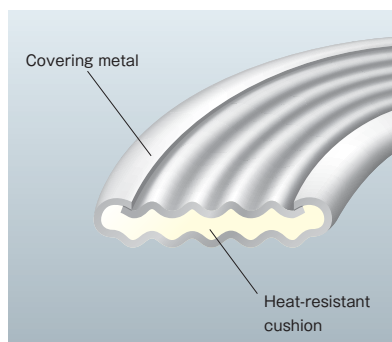

A metal jacketed gasket is a gasket that has an inorganic heat-resistant cushion covered by a thin metal plate. It is manufactured in various shapes and covering methods depending upon the intended application and the location where it is to be used. It is used for high temperature coupling flanges and man-holes, etc. for heat exchangers, pressure vessels, towers and vessels, equipment, valves, etc.



Comparison of semi-metallic gaskets

Recommended service range
Usable range (The usable range varies according to the conditions of use. Be sure to consult us in advance.)

Product name

Construction

Features

Service range

TOMBO™ No.

1891 series

Kammprofile gasket

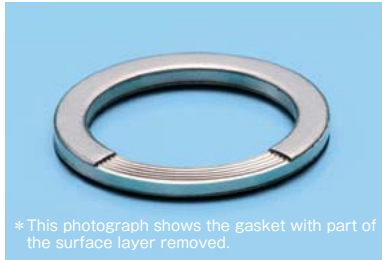

* This photograph shows the gasket with part of the surface layer removed.

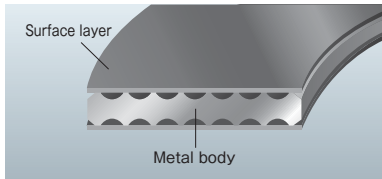

- Can be used under severe conditions encountered in a heat cycle, and exhibits excellent sealing performance even when a small tightening force is used.
- There is no need for an inner ring to stop buckling. This enables this gasket to be designed with a narrow width.
- There is no need to worry about the gasket breaking up even in the case of a large bore gasket.
- Suitable for use in heat exchangers and pressure vessels.

Water-type, oil-type, gas-type or corrosive fluids

TOMBO™ No.1891-GR

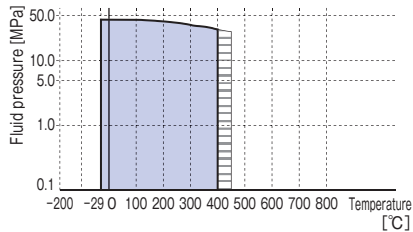

Water-type, oil-type, gas-type or corrosive fluids

TOMBO™ No.1891-TF

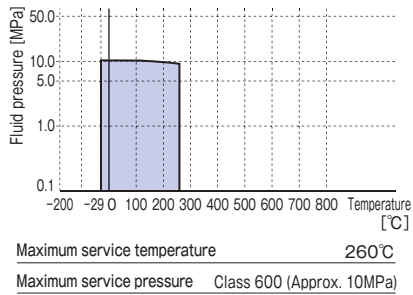

* When using TOMBO™ No.1891 at Class 400 or higher, use an interlocking type (M&F) or a grooved type (T&G) flange.

For details of a kammprofile gasket, see P.39 and P.40.

TOMBO™ No.

1834R-GR series

GRASEAL™ VORTEX™ gasket

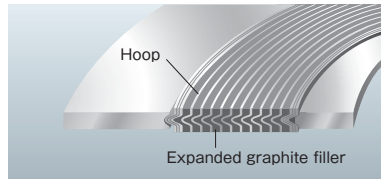

- Exhibits excellent sealing performance even under severe conditions such as high temperature and high pressure, extremely low temperatures, or heat cycles.
- It is suitable for a variety of applications in pipes, equipment, etc.

Water-type fluid

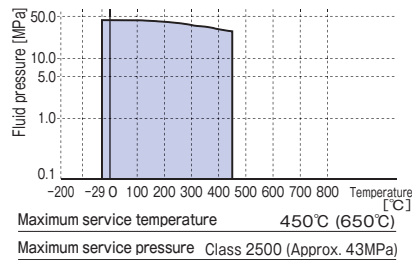

Oil-type, gas-type or corrosive fluids

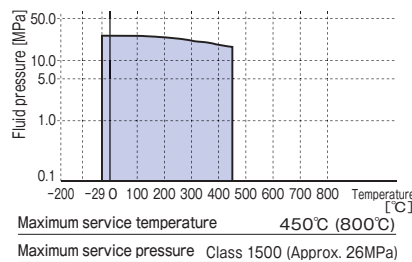

Low temperature fluids

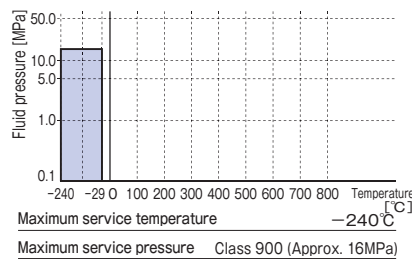

* This temperature is the maximum temperature when used in the Face and groove (F&G) type flange under the condition of non-oxidizing fluid.

TOMBO™ No.

9090-IOR series

NAFLON™ VORTEX™ gasket

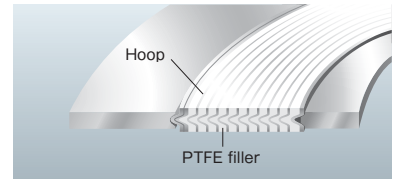

- Can be used with corrosive fluids and pure oxygen gas, in vacuum lines that require airtightness.
- Can be used in pipes, pressure vessels, heat exchangers, valve bonnets, etc.

Water-type, oil-type, gas-type or corrosive fluids

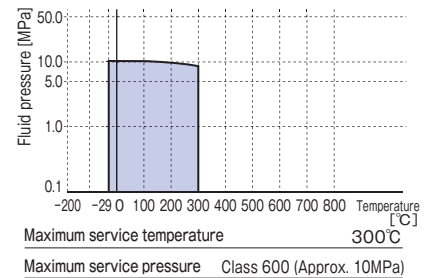

Low temperature fluids

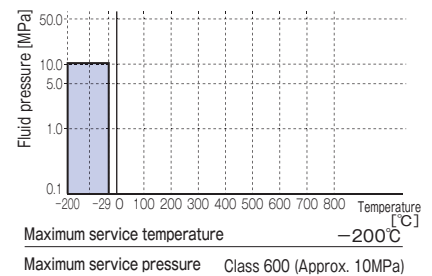

These gaskets use metal as a base material, so they can be used at higher temperature and pressure compared to a sheet gasket. These gaskets fit well with the flanges, so a good seal can be obtained using a smaller tightening force compared to a metal gasket.

TOMBO™ No.

1834R-NA series

NA VORTEX™ gasket

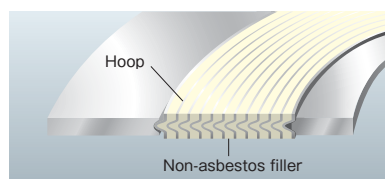

● This is an economical VORTEX™ gasket which uses non-asbestos (NA) paper as a filler.

* As long as there are no restrictions to use black filler, the use of GRASEAL™ VORTEX™ which has superior heat resistance and sealing performance is recommended.

Water-type fluid

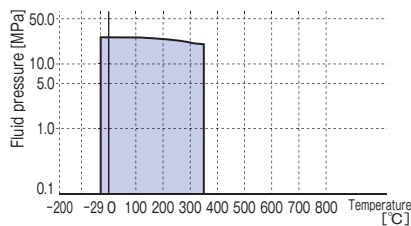

Maximum service temperature 350°C

Maximum service pressure Class 1500 (Approx. 26MPa)

Oil-type fluid

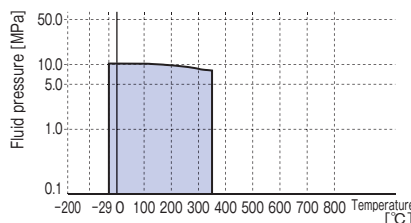

Maximum service temperature 350°C

Maximum service pressure Class 600 (Approx. 10MPa)

Gas-type fluid

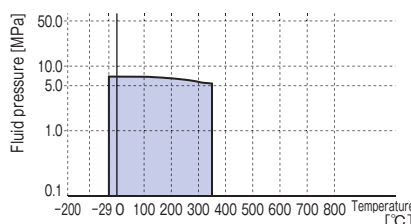

Maximum service temperature 350°C

Maximum service pressure Class 400 (Approx. 7MPa)

TOMBO™ No.

1836R-GS/-GM/-GH series

VORTEX™ gasket -GS / -GM / -GH

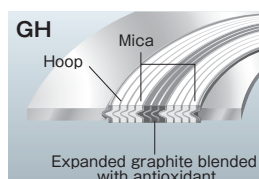
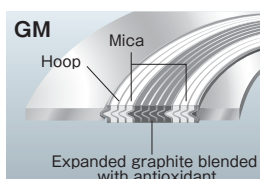
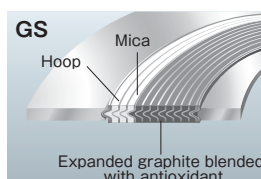
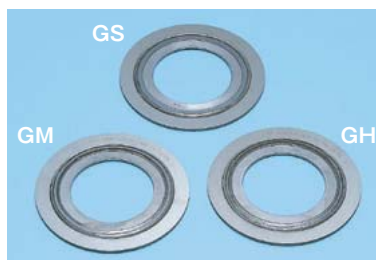

● This gasket uses a special expanded graphite filled with antioxidant, enabling it to be used at a temperature of 450°C or higher.

* The sealing performance of the normal GRASEAL™ VORTEX™ gasket is superior to this type.

● One of three types, -GS, -GM and -GH, can be selected according to the conditions of use.

-GS series: A location where oxygen is not contained in the internal fluid

-GM series: Temperature of 450°C or higher

-GH series: Temperature of 650°C or higher

Water-type and oil-type fluids

-GS series, -GM series

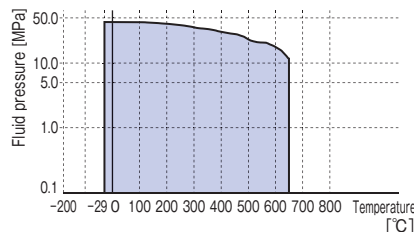

Maximum service temperature 650°C

Maximum service pressure Class 2500 (Approx. 43MPa)

Water-type and oil-type fluids

-GH series

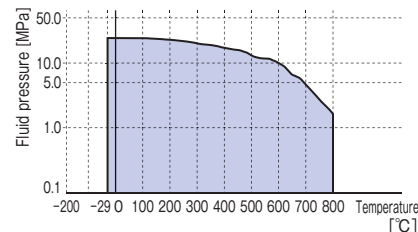

Maximum service temperature 800°C

Maximum service pressure Class 1500 (Approx. 26MPa)

Oil-type and gas-type fluids

-GS series, -GM series

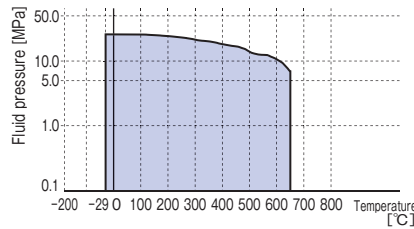

Maximum service temperature 650°C

Maximum service pressure Class 1500 (Approx. 26MPa)

Gas-type fluids

-GH series

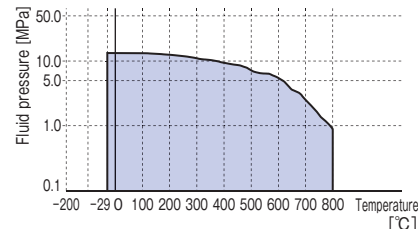

Maximum service temperature 800°C

Maximum service pressure Class 600 (Approx. 10MPa)

* In the case of a gas-type fluid at 650°C or higher, use Class 600 or lower.

* This product has been designed to minimize the loss of expanded graphite through oxidation. If oxygen is contained in the internal fluid, however, it is possible that the loss of expanded graphite will start to occur when the temperature exceeds 450°C.
Do not use type of gasket over 450°C if the internal fluid contains oxygen.
Do not use -GM, -GH type of gasket over 450°C if the internal fluid contains air.

For details of VORTEX™ gaskets, see P.42 to P.49.

Product name

Construction

Features

Service range

TOMBO™ No.
1839R series
 GRASEAL™ VORTEX™ gasket -L

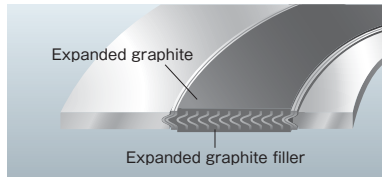

- This gasket consists of large quantity of filler on the seal face, enabling a satisfactory seal to be obtained when using a smaller tightening force than that of a normal GRASEAL™ VORTEX™ gasket.
- Can be used in a low-temperature line containing LNG, LN₂, liquefied air, etc.

Water-type, oil-type, gas-type or corrosive fluids

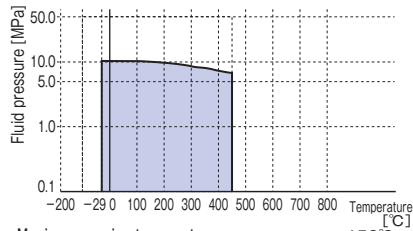

Maximum service temperature **450°C**
 Maximum service pressure Class 600 (Approx. 10MPa)

Low-temperature fluid

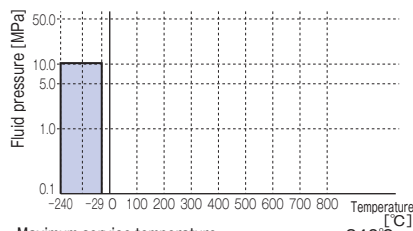

Maximum service temperature **-240°C**
 Maximum service pressure Class 600 (Approx. 10MPa)

TOMBO™ No.
1839R-AL series
 GRASEAL™ VORTEX™ gasket -AL

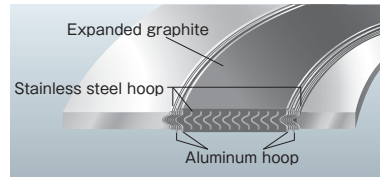

- This GRASEAL™ VORTEX™ gasket for aluminum flanges is constructed in such a way that it does not easily damage the flange face.
- Can be used in low-temperature lines carrying LNG, LNN₂, etc.

Water-type, oil-type and gas-type fluids

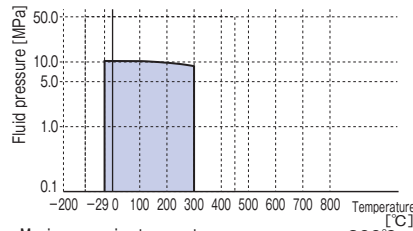

Maximum service temperature **300°C**
 Maximum service pressure Class 600 (Approx. 10MPa)

Low-temperature fluid

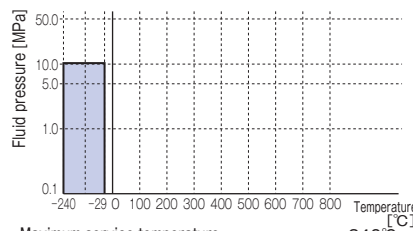

Maximum service temperature **-240°C**
 Maximum service pressure Class 600 (Approx. 10MPa)

TOMBO™ No.
1841/1861
 Metal jacketed gasket/Corrugated metal jacketed gasket

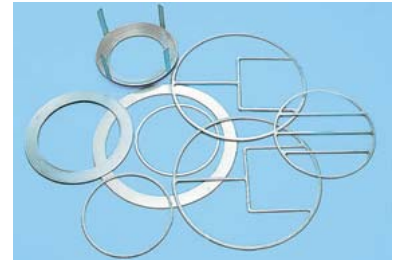

TOMBO™ No.1841



TOMBO™ No.1861

- This gasket can be manufactured in various shapes, such as a branched type, according to the particular application and the intended location.
- It is used in heat exchangers, pressure vessels, towers and vessels, equipment, valves, high-temperature coupling flanges, manholes, etc.

The maximum service temperature of a metal jacketed differs according to the type of core material and cover metal.

Maximum service temperature for different core materials

Millboard	530°C
Millboard for high-temperature	1300°C
Expanded graphite	400°C

Maximum service pressure

6MPa

Maximum service temperature by cover metal

Carbon steel	535°C
304 stainless steel	800°C
316 stainless steel	800°C
Copper	400°C
Aluminum	400°C
310S stainless steel	1150°C
Monel	800°C

For details of a metal jacket gasket, see P.50 and P.51.

For details of VORTEX™ gaskets, see P.42 to P.49.



TOMBO™ No. 1891

Kammprofile gasket

Lineup

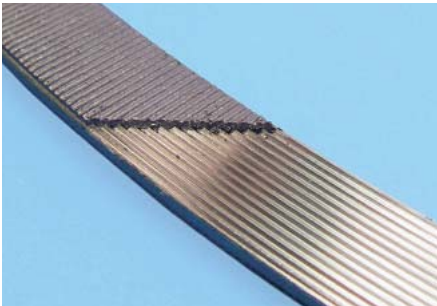

Expanded graphite clad gasket (TOMBO™ No.1891-GR)
* This photograph shows the gasket with part of the surface layer removed.

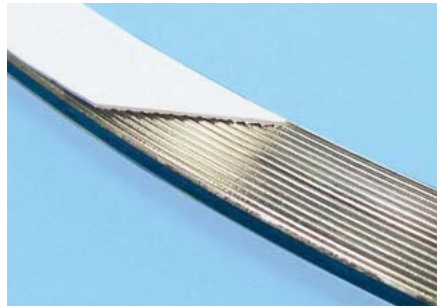

PTFE clad gasket (TOMBO™ No.1891-TF)

(Example of metal body material)

304 stainless steel	Carbon steel
316L stainless steel	329J4L
321 stainless steel	Monel
	Titanium
	Nickel

* For other materials, please contact us.

■ Understanding TOMBO™ No. When placing an order, please include the following product specifications (TOMBO™ No.).

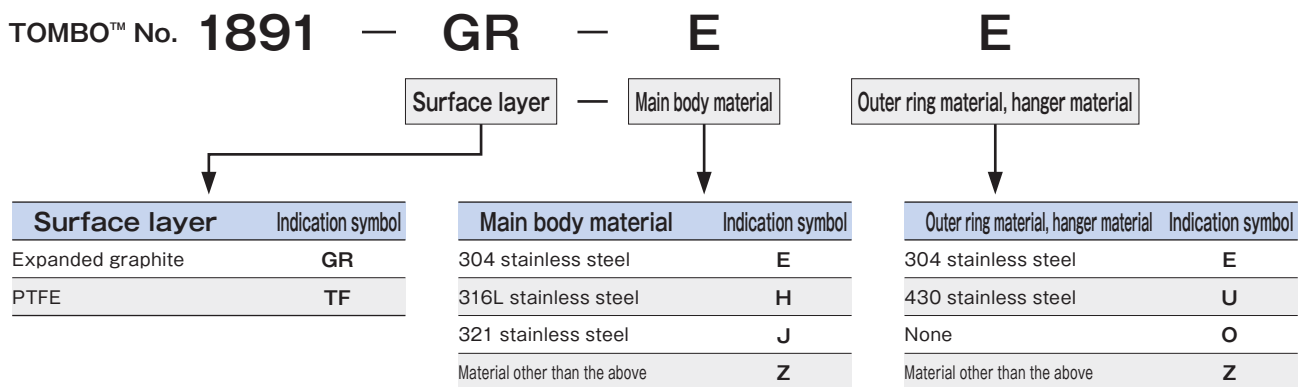

* In the case of a branched type gasket or a gasket with a hanger, clearly indicate the dimensions.

Design criteria

TOMBO™ No.	1891-GR	1891-TF
Gasket coefficient m	[-]	
Minimum design seating stress γ	[N/mm ²]	
Minimum seating stress σ_3	Water-type and oil-type fluids	29.4
	Gas-type fluid	39.2
Allowable seating stress	[N/mm ²]	
	450	

Standard dimensions

Standard O.D. [mm]	ϕ 4000 ⁽¹⁾
Standard thickness [mm]	4.0 (Metal thickness: 3.0, Cover material: 0.5×2 = 4.0)
Standard width [mm]	10, 13, 15, 20
Minimum manufacturable width [mm]	5 ⁽²⁾
Standard metal main body material	304 stainless steel, 316L stainless steel
Standard hanger material	304 stainless steel
Construction	Basic type, type with hangers, branched type

Note :

(1) For gaskets larger than ϕ 4000mm, please consult us. We can also manufacture gaskets to specifications other than those shown at left.

Note, however, that due to structural considerations we are unable to manufacture the fully-seating type gaskets with bolt holes or irregularly shaped (track type or, elliptical type) gaskets.

In such a case, please consider the use of TOMBO™ No.1880-GR (CMGC gasket).

(2) This is the minimum width to which a gasket can be manufactured. Please note that the minimum width that can provide satisfactory sealing performance varies according to the conditions of use.

■ Design guideline concerning the standard clearance and appropriate groove depth

● Groove to gasket clearance

Gasket [mm]	Standard clearance [mm]	
	(a)	(b)
250 or lower	0.5	0.5 or higher
251 ~ 630	0.7	0.7 or higher
631 ~ 2000	1.0	1.0 or higher
2001 ~ 3000	1.3	1.3 or higher
3001 or higher	1.5	1.5 or higher

● Groove depth (when the gasket thickness is 4mm)

Flange seat type	Appropriate groove depth (f) [mm]
Tongue and groove type (T&G)	5.0 min.
Male and female type (M&F)	5.0 min.

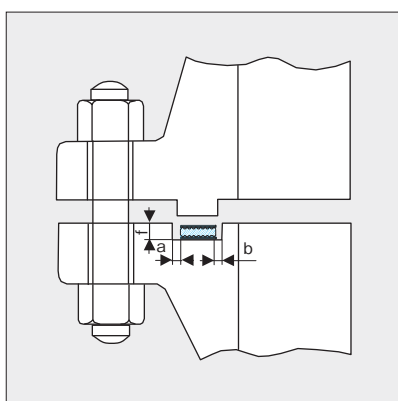

When used in a tongue and groove (T&G) type flange

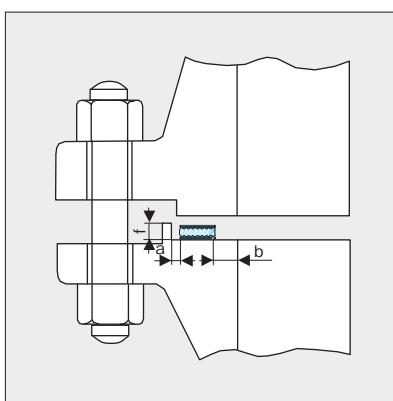

When used in a male and female (M&F) type flange

■ Flange facing type and appropriate gasket shape

Flange facing type	Flat Face (FF)	Raised Face (RF)	Male and Female (M&F)	Tongue and Groove (T&G) ⁽²⁾
	Appropriate shape	Gasket with hanger ⁽¹⁾	Gasket with hanger ⁽¹⁾	Basic type

Note : (1) In the case of a piping standard gasket (Class 150 /Class 300), the gasket has an outer ring.

(2) In the case of Class 400 or higher, the use of the tongue and groove type (T&G) flange is recommended.

⚠ Precautions for use

- A Kammprofile gasket is clad with expanded graphite or PTFE. For this reason, the surface of the gasket is easily damaged. If the damage causes the metal to be exposed, leakage may occur. Handle the gasket carefully.
- A Kammprofile gasket clad with expanded graphite cannot be used with the fluids shown in the table at right, as a general rule.

Fluids for which a Kammprofile gasket (clad with expanded graphite) is not suitable.

Classification	Name of fluid
Oxidizing acid	Nitric acid, concentrated sulfuric acid, hot sulfuric acid, chromic acid, mixed acid, etc.
Oxidizing salt	Nitrate, chloride, hypochlorite, etc.
Halogen compound	Bromine, fluorine, iodine, chlorine dioxide, etc.
Combustible gas	Oxygen (pure oxygen)

Shapes of gaskets for heat exchangers

Nichias can manufacture semi-metallic gaskets that are suitable for various heat exchangers. They are used in a wide range of applications. When placing an order, please specify the desired shape using the corresponding abbreviation shown below, or a drawing.

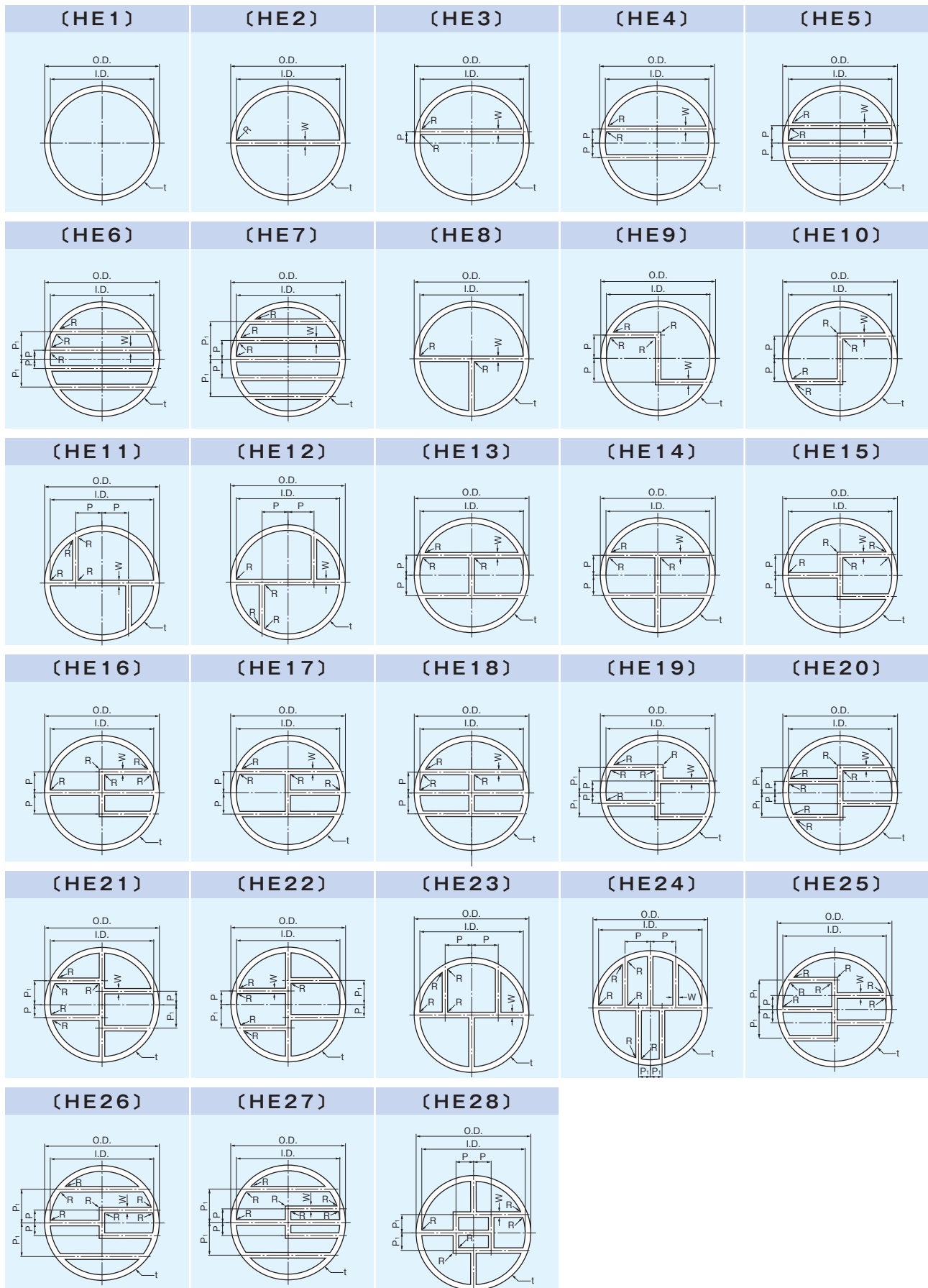



VORTEX™ gaskets

For details of the design criteria and the standard dimensions, see P.46.

For handling precautions, see P.49.

Lineup

Nichias VORTEX™ gaskets are available in the following special shapes, in addition to the basic type gaskets and gaskets with inner and outer rings.

Inner ring rod type

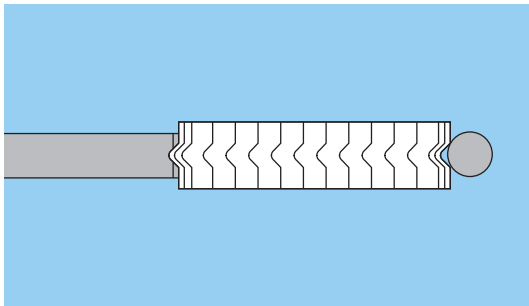

- This type of gasket has a metal rod installed at the I.D. side. It is intended to be used in a place where the width of the necessary inner ring is narrow.
- When the bore is large, this gasket may buckle. TOMBO™ No.1891 (Kammprofile gasket) is recommended.

Gasket thickness ⁽¹⁾	4.5mm
Rod diameter	φ 3.2mm
Standard material	304 steel, 316 steel

Note : (1) This gasket is available only in a thickness of 4.5mm, as a general rule.

Wound metal hoop type

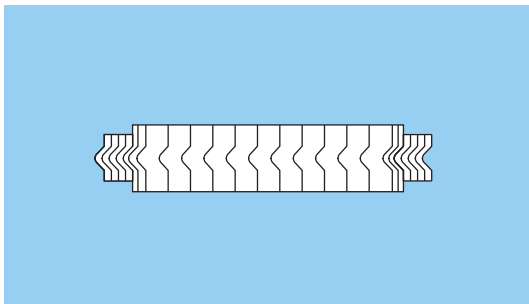

- This gasket has a 3.2mm winding metal hoop at the I.D. side or the O.D. side.
- This gasket is used on an M&F type or T&G type the flanges of which have insufficient width to permit the use of an outer ring.
- The winding metal part does not have the same degree of strength as the inner ring or outer ring, so this type of gasket is not suitable for an FF or an RF type flange.

Gasket thickness ⁽¹⁾	4.5mm	
Wound metal part	Thickness	3.2mm
	Maximum width	3.0mm

Note : (1) This gasket is available only in a thickness of 4.5mm, as a general rule.

〈Effectiveness of winding metal〉

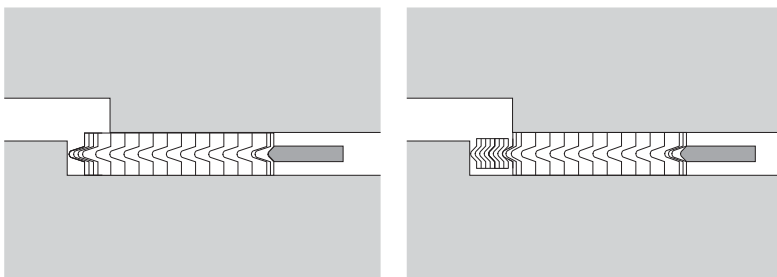

When the gasket main body has moved from the seat

When the wound metal hoop type is used

In the case of an M&F or T&G flange, if the clearance between the tongue and the groove is large, the main body of the gasket may slip off the flange seat as shown in the figure at left, resulting in possible leakage. When a wound metal hoop type gasket is used, the winding metal part functions to prevent centering and abnormal deformation to the O.D. side. It thus eliminates the risk of the main body slipping off the seat.

Branched type for heat exchanger

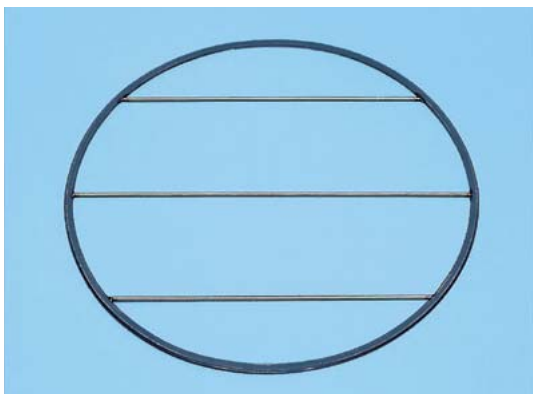

- This type of gasket can be made to any desired shape. It is suitable for use in multipath type heat exchangers.

Types of gasket body	NA VORTEX™, GRASEAL™ VORTEX™, NAFLON™ VORTEX™		
Type of branch (For a thickness of 4.5mm)	Hollow metal tube	Material	321 stainless steel
		Dimensions	4.8 (pipe diameter) × 0.5 (wall thickness)
	TOMBO™ No.1841 (Metal jacket)	Cover metal	Normally, same as the material of the hoop or inner ring
		Standard shape	10 (width) × 4.7 (thickness)

Irregular shaped type



- This type of gasket is used mainly for boiler manholes, hand holes, and valve bonnets.

- When placing an order for a gasket, please specify the dimensions A, B, C, R1, R2, and R3 shown in the diagrams. In the case of a diamond shape, if R3 is a straight line, there is no need to specify R3.
- In the case of an elliptical or track type, dimension A must be at least 40mm. In the case of a diamond type, dimension A must be at least 60mm.
- The ratio A/B must be at least 2/3.
- Because this type of gasket may break apart, ensure that the straight part (indicated by ★ in the diagrams below) is no more than 100mm, as a rough guide. If it is necessary to use a straight length of more than 100mm, use TOMBO™ No.1880-GR (CMGC gasket).

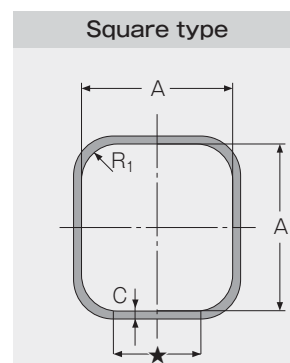
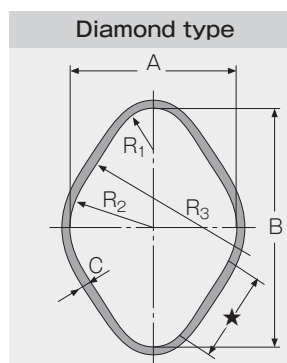
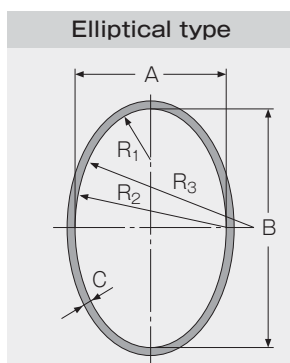
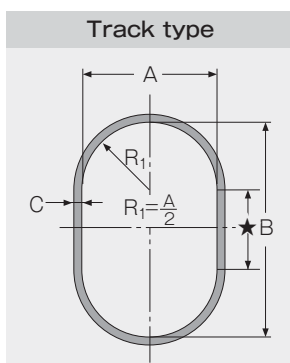

■ **Understanding TOMBO™ No.** When placing an order, specify the following product specifications (TOMBO™ No.).

TOMBO™ No. **1804** – **EX** – **GR** – **000** – **G**

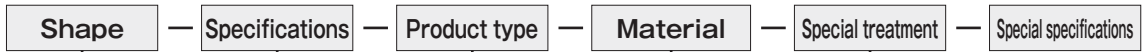

Specifications ⁽¹⁾	Indication symbol
Branched type for heat exchangers	EX
With I.D. rod	RD
I.D. wound metal hoop	IH
O.D. wound metal hoop	OH
I.D./O.D. wound metal hoop	IOH
General specifications	No symbol

Note: (1) In the following cases, the notations differ from the above.

NAFLON™ VORTEX™ inner ring rod type with an outer ring	9090 RD OR
NAFLON™ VORTEX™ I.D. wound metal hoop with an outer ring	9090 IH OR

Necessary only when special specifications are agreed upon individually with the user.

Shape	Hoop material	Indication symbol
Basic type	304 stainless steel	1804
	316 stainless steel	1806
	Other materials	1808
With inner ring	304 stainless steel	1804 R
	316 stainless steel	1806 R
	Other materials	1808 R
With outer ring	304 stainless steel	1834
	316 stainless steel	1836
	Other materials	1838
With inner and outer rings	304 stainless steel	1834 R
	316 stainless steel	1836 R
	Other materials	1838 R

Type of product	Indication symbol
GRASEAL™ VORTEX™ gasket	GR
NA VORTEX™ gasket	NA
VORTEX™ gasket -GS	GS
VORTEX™ gasket -GM	GM
VORTEX™ gasket -GH	GH

Shape	Indication symbol
Basic type	1809
With inner ring	1809 R
With inner and outer rings	1839 R

Type of product	Indication symbol
GRASEAL™ VORTEX™ gasket-L	No symbol
GRASEAL™ VORTEX™ gasket for aluminum flange	AL

Shape	Indication symbol
Basic type	9090
With inner ring	9090 -IR
With outer ring	9090 -OR
With inner and outer rings	9090 -IOR

Type of product	Indication symbol
NAFLON™ VORTEX™ gasket	No symbol

Examples of TOMBO™ No.

Special treatment	Indication symbol
General product	No symbol
Gas-tight treatment	G
Degreasing	K
For oxygen (OX treatment)	OX

- * Products that can be subjected to G treatment or K treatment
- GRASEAL™ VORTEX™
- GRASEAL™ VORTEX™ -L
- GRASEAL™ VORTEX™ for aluminum flange
- * Products that can be subjected to OX treatment
- OX treatment refers to a gasket that has been degreased and made suitable for oxygen lines in which even a minute amount of oil is not permitted.

1806-GR-GOO

Shape	Product type	Hoop material	Inner ring material	Outer ring material
Basic type	GRASEAL™ VORTEX™	316 stainless steel	None	None

1834-NA-EOS

Shape	Product type	Hoop material	Inner ring material	Outer ring material
With outer ring	NA VORTEX™	304 stainless steel	None	Carbon steel

9090-IOR-TTG

Shape	Type of product	Hoop material	Inner ring material	Outer ring material
With inner and outer rings	NAFLON™ VORTEX™	Titanium	Titanium	316 stainless steel

1838-IH-GR-ZZZ

Shape	Specifications	Product type	Hoop material	Inner ring material	Outer ring material
With outer ring	I.D.wound metal hoop	GRASEAL™ VORTEX™	Others (1)	Others (1)	Others (1)

Note : (1) In the case of "Others", specify the material name.

Recommended service temperature for material⁽²⁾ and applicable standards

Material	Recommended service temperature	Applicable standards
Carbon steel	—	JIS G 3141 SPCC JIS G 3131 SPHC ASTM A285 Grade-C SNI-07-0601-BjPC (Indonesian standard)
304 stainless steel	500°C max.	UNS No. S30400 JIS G4305 SUS304 ASTM A240 TYPE304
304L stainless steel	500°C max.	UNS No. S30403 JIS G4305 SUS304L ASTM A240 TYPE304L
309S + Cb stainless steel	—	AISI 309S+Cb
316 stainless steel	600°C max.	UNS No. S31600 JIS G4305 SUS316 ASTM A240 TYPE316
316L stainless steel	600°C max.	UNS No. S31603 JIS G4305 SUS316L ASTM A240 TYPE316L
316ELC stainless steel	—	AISI 316ELC (Corresponds to JIS G4305 SUS316L and C content of 0.025% max.)
310S stainless steel	—	UNS No. S31008 JIS G4305 SUS310S ASTM A240 TYPE310S
347 stainless steel	750°C max.	UNS No. S34700 JIS G4305 SUS347 ASTM A240 TYPE347
Alloy 600	800°C max.	UNS No. N06600 JIS G 4902 NCF600 ASTM B168 N06600
Alloy 400	750°C max.	UNS No. N04400 JIS H 4551 NcuP ASTM B127 N04400
Titanium	500°C max.	JIS H 4600 Type 2 TR340C
321 stainless steel	750°C max.	UNS No. S32100 JIS G4305 SUS321 ASTM A240 TYPE321

Note : (2) Recommended service temperature as hoop material

[Reference: Old material symbol]

Carbon steel	SS	316L stainless steel	316L	430 stainless steel	430
304 stainless steel	304	316ELC stainless steel	316ELC	Alloy 600	Y
304L stainless steel	304L	321 stainless steel	321	Alloy 400	M
309S + Cb stainless steel	309S+CB	347 stainless steel	347	Titanium	T
316 stainless steel	316	410 stainless steel	410	Others	—

Material	Material	Material
Hoop material	Inner ring material (rod and wound metal materials) ⁽¹⁾	Outer ring material (wound metal material)
Indication symbol	Indication symbol	Indication symbol
—	None	None
304 stainless steel	304 stainless steel	304 stainless steel
316 stainless steel	316 stainless steel	316 stainless steel
316L stainless steel	316L stainless steel	316L stainless steel
321 stainless steel	321 stainless steel	321 stainless steel
Titanium	Titanium	Titanium
304L stainless steel	304L stainless steel	304L stainless steel
309S + Cb stainless steel	347 stainless steel	347 stainless steel
316ELC stainless steel	Alloy 600	Alloy 600
347 stainless steel	Alloy 400	Alloy 400
Alloy 600	410 stainless steel	410 stainless steel
Alloy 400	430 stainless steel	430 stainless steel
Nickel	Carbon steel	Carbon steel
310S stainless steel	Others	Others
410 stainless steel		
Others		

Standard materials of TOMBO™ No.1804-GR series (GRASEAL™ VORTEX™).
Materials not specified as standard or not listed here may be used under special individual specifications. Please contact us for details. In such a case, use the symbol "Z" and indicate the material name.

Note : (1) In the case of a gasket with an I.D. rod (RD), indicate the rod material. In the case of a wound metal hoop type (IH, OH, IOH), indicate the material of the wound metal hoop. In the case of IOH, specify the material in the sequence I.D. wound metal followed by O.D. wound metal.

■ Design criteria

TOMBO™ No. ⁽¹⁾	1804-GR	1804-NA	9090	1806-GS -GM, -GH	1809 1809-A L	
Gasket coefficient m [-]	3.00				3.00	
Minimum design seating stress γ [N/mm ²]	68.9				58.8	
Minimum seating stress σ_3 [N/mm ²]	Water-type and oil-type fluids	29.4	34.3	29.4	34.3	—
	Gas-type fluids	39.2	78.4	39.2	78.4	Class150 29.4
						Class300 39.2
Class600 49.0						
Allowable seating stress [N/mm ²]	294.2				294.2	

Note : (1) Indicates the TOMBO™ No. for the basic type.

■ Standard dimensions

Gasket thickness [mm] ⁽¹⁾	Inner and outer ring thickness [mm]		Recommended I.D. ⁽²⁾ [mm]	
	Carbon steel	Other than carbon steel	Min.	Max.
3.2	2.0	2.0	φ 16	φ 600
4.5 (Standard)	3.2	3.0	φ 16	φ 3000
6.4	4.5	4.0	φ 1500	φ 3000

Note : (1) When this gasket is to be used as a pipe flange gasket, use a gasket thickness of 4.5mm as a general rule.

(2) We can also manufacture gaskets to the dimensions other than the above. However, this may result in deformation, warping or breaking up of the gaskets. In addition, the delivery period may be longer than normal due to the custom specifications. Please consult us for details.

■ Recommended width of the main body of the gasket (When the gasket thickness is 4.5mm)

When individually setting the Vortex dimensions, ensure that the width of the main body of the gasket is the recommended minimum width indicated in the minimum diagram below.

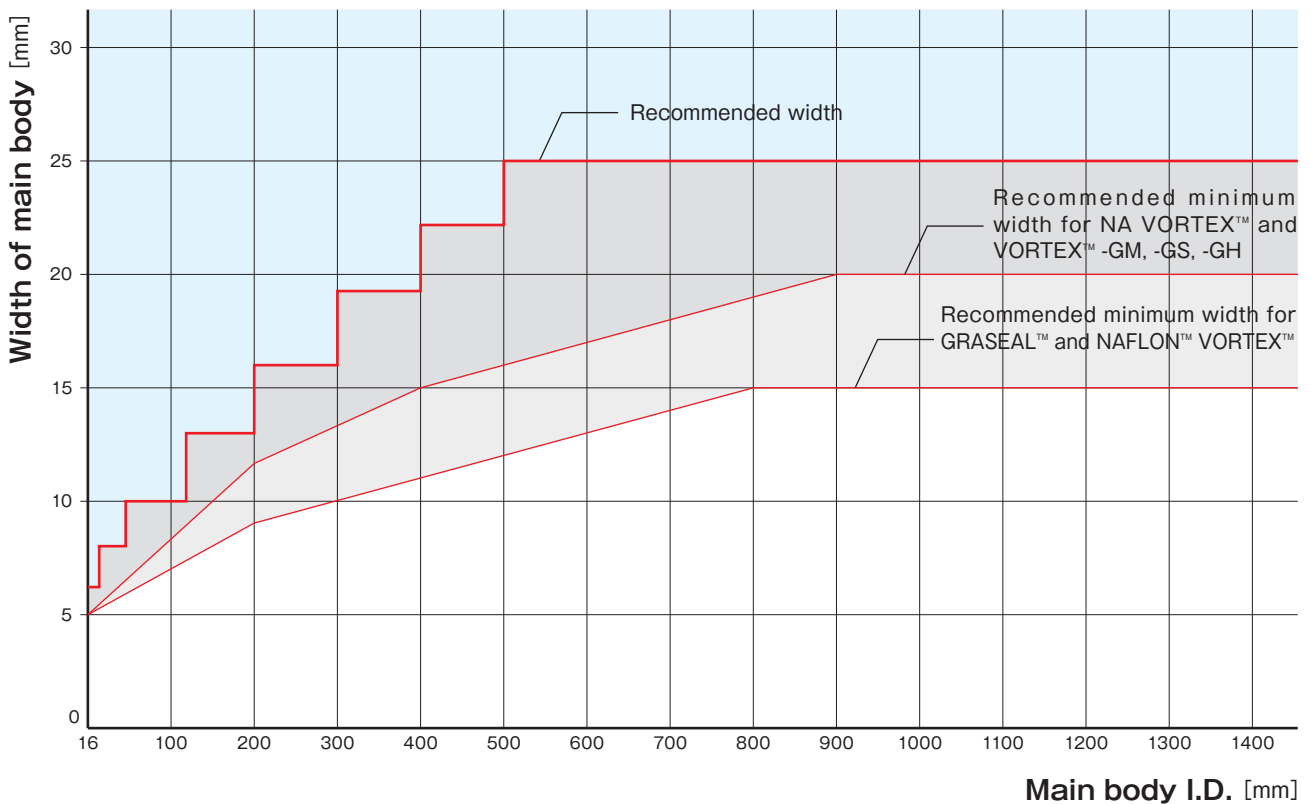

Available range of gasket widths

Main body I.D. Inner ring I.D. Outer ring I.D. [mm]	Range of available main body widths [mm]			Minimum available width of inner ring [mm]	Minimum available width of outer ring [mm]
	Main body thickness: 3.2	Main body thickness: 4.5	Main body thickness: 6.4		
16 ~ 30	4.0 ~ 10	4.5 ~ 10	—	2.5	—
31 ~ 46	4.0 ~ 15	4.5 ~ 15	—	2.5	4
47 ~ 55	4.0 ~ 20	4.5 ~ 20	—	3	4
56 ~ 70	4.0 ~ 22	4.5 ~ 25	—	3	4
71 ~ 90	4.0 ~ 22	4.5 ~ 30	—	3.5	4
91 ~ 110	4.5 ~ 22	5.0 ~ 35	—	3.5	4
111 ~ 150	4.5 ~ 22	5.0 ~ 35	—	4	4
151 ~ 170	4.5 ~ 22	5.0 ~ 40	—	4	4.5
171 ~ 200	4.5 ~ 20	5.0 ~ 40	—	4	4.5
201 ~ 300	4.5 ~ 20	5.0 ~ 40	—	4.5	4.5
301 ~ 400	4.5 ~ 18	5.0 ~ 40	—	5	5
401 ~ 500	5.0 ~ 18	5.5 ~ 40	—	5.5	5.5
501 ~ 600	5.5 ~ 15	6.0 ~ 35	—	6	6
601 ~ 700	—	6.5 ~ 35	—	7	7
701 ~ 800	—	7.0 ~ 35	—	8	8
801 ~ 900	—	7.5 ~ 35	—	9	9
901 ~ 1000	—	8.0 ~ 30	—	10	10
1001 ~ 1100	—	8.5 ~ 30	—	11	11
1101 ~ 1200	—	9.0 ~ 30	—	11	12
1201 ~ 1300	—	10.0 ~ 27 (25)	—	11	13
1301 ~ 1400	—	11.0 ~ 27 (25)	—	11	14
1401 ~ 1500	—	12.0 ~ 27 (25)	—	11	15
1501 ~ 1600	—	(12) ~ 27 (25)	(12) ~ 30	15	16
1601 ~ 1700	—	(12) ~ 25 (22)	(12) ~ 30	15	17
1701 ~ 1800	—	(12) ~ 25 (22)	(12) ~ 30	15	18
1801 ~ 1900	—	(12) ~ 25 (22)	(12) ~ 30	15	19
1901 ~ 2000	—	(12) ~ 25 (22)	(12) ~ 30	20	20
2001 ~ 2100	—	(12) ~ 22 (20)	(12) ~ 30	20	20
2101 ~ 2200	—	(12) ~ 20	(12) ~ 30	20	20
2201 ~ 2300	—	(12) ~ 20	(12) ~ 25	20	20
2301 ~ 2500	—	(12) ~ 18	(12) ~ 25	20	20
2501 ~ 2800	—	—	(12) ~ 22	20	20
2801 ~ 3000	—	—	(12) ~ 20	20	20

* We can also manufacture gaskets to the dimensions other than the above. However, this may result in deformation, warping or breaking up of the gaskets, and also the delivery period may be longer than normal due to the custom specifications. Please consult us for details.

* The numbers in parenthesis are reference values.

* The numbers in the above table are for gaskets with expanded graphite filler. The numbers in [] are for gaskets with PTFE filler and a titanium hoop.

* The thickness of TOMBO™ No.1809, 1809-AL or an irregular shaped VORTEX™ gasket is limited to 4.5mm only, as a general rule.

* The maximum available size of TOMBO™ No.1809 is ϕ 1200, and that of TOMBO™ No.1809-AL is ϕ 600. If you require a larger size, please consult us.

■ Design guidelines concerning the standard clearance and appropriate groove depth

(Tongue and groove (T&G) type or male and female (M&F) type flange)

● Gasket clearance

Main body of gasket [mm]	Standard clearance [mm]	
	(a)	(b)
250 or less	0.5	0.5
251 ~ 630	0.7	0.7
631 ~ 1600	1.0	1.0
1601 or more	1.5	1.5

● Groove depth

Gasket thickness [mm]	Appropriate groove depth (f) [mm]
3.2	3.5 min.
4.5	5.0 min.
6.4	7.0 min.

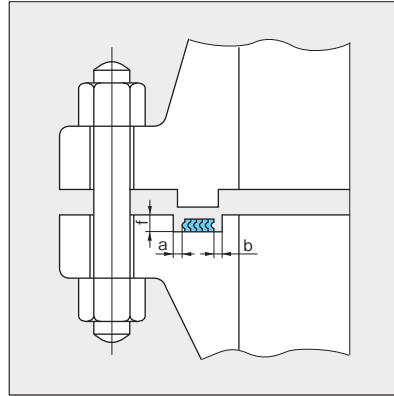

When used in a tongue and groove type flange

(Face and groove (F&G) type flange)

● Gasket clearance

The clearance (b) differs according to the gasket seating stress. Please consult us for details.

● Groove depth

Gasket thickness [mm]	Appropriate groove depth (f) [mm]
3.2	2.4 (+0.1, -0)
4.5	3.2 (+0.1, -0)
6.4	—

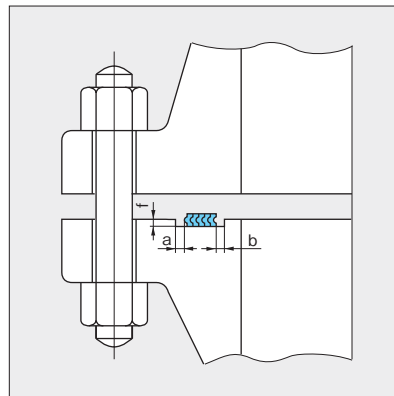

When used in a face and groove type flange

■ Flange facing type and appropriate gasket shape

Flange facing type	Flat Face (FF)	Raised Face (RF)	Male and Female (M&F)	Tongue and Groove (T&G)
Applicable shape	With inner and outer rings	With inner and outer rings	With inner ring	Basic type

* A VORTEX™ gasket requires a larger tightening force compared to a soft gasket, so it cannot be used on a flange for low pressure (JIS 2K, 5K, vacuum flange, etc.).

* For an aluminum flange, use a TOMBO™ No.1809-AL series gasket. The use of another VORTEX™ gasket may cause damage to the flange.

* If all of the following conditions are satisfied, the gasket can be used without an inner ring.

- Size (nominal diameter): ϕ 24B or less or 600A or less
- Pressure rating: Class 600 or less or 40K or less
- NA VORTEX™ gasket

⚠️ Precautions for VORTEX™ gaskets

■ Precautions concerning design and selection

● Finish of the gasket seat

The recommended surface roughness of the seat of a VORTEX™ gasket is as follows.

- For sealing liquid: 6.3 μm Ra max.
- For sealing gas: 3.2 μm Ra max.

● Bolt material

A VORTEX™ gasket requires a larger tightening force compared to a soft gasket. The use of high tension bolts made of SNB7 or higher is recommended.

● Shape of VORTEX™

The inner ring functions to prevent buckling of the main body of the gasket, maintain high tightening force, and prevent the gasket from breaking (breaking up), and to prevent deformation of the main body of the gasket to the I.D. side when the gasket is tightened. Be sure to select a type with an inner ring if it is to be installed onto a flange that is unconstrained on the I.D. side, and also in the following cases:

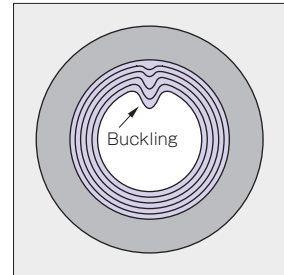

- If the filler used has a low friction coefficient, like GRASEAL™ and NAFLON™
- When the pressure rating of the flange is Class 900 {63K} or higher
- When the nominal diameter of the flange is 650A {26B} or larger

● Recommended gaskets for various kinds of fluids

Fluid	Precautions	Recommended gaskets
Combustible gas	Do not use a GRASEAL™ VORTEX™ or NA VORTEX™ gasket. There is a possibility of loss of GRASEAL™ and the organic component of the NA filler due to oxidation.	● NAFLON™ VORTEX™ for oxygen (TOMBO™ No.9090-OX series)
Strongly oxidizing fluid (oxidizing acids, oxidizing salts, halogen components)	Do not use GRASEAL™ VORTEX™ gaskets. There is a possibility of GRASEAL™ being oxidized.	● NAFLON™ VORTEX™
High-temperature fluid	Select materials for the hoop and inner ring that can withstand the conditions under which the gasket is to be used.	● VORTEX™ gasket -GS, -GM ● VORTEX™ gasket -GH (when the oxidizing strength of the fluid is weak)
Corrosive fluid	Do not use an NA VORTEX™ gasket because the fluid corrodes the filler.	● GRASEAL™ VORTEX™, NAFLON™ VORTEX™ (Select materials for the inner and outer rings and hoop that can withstand the fluid.)

■ Precautions for use

● Before installation

- Before installing a gasket, clean the flange face and confirm that it is free of foreign matter and damage.
- Handle a gasket with care. Particularly, a large bore gasket may break (break up), arrange several persons handle it carefully.
- Place a gasket in a suitable position so that it does not shift to one side of the flange.
- There is no need to apply gasket paste, as a general rule. However, if it is necessary and the temperature is not higher than 300°C, apply No.9400 (NAFLON™ paste).
- You cannot reuse a gasket.

● When using a basic type of VORTEX™ gasket

A basic type VORTEX™ gasket (including an irregularly shaped gasket) may deform under a very small force, so be very careful when installing it. Note that even if the gasket becomes slightly deformed, it may be possible to insert it into the flange groove and use it as it is, please consult us for this matter.

Applicable standards

■ JIS F 0602

"Shipbuilding - Non-asbestos gaskets to cargo piping system - Application standard" (HUC TOMBO™ No.1834-NA, HUD TOMBO™ No.1834R-NA, KUD TOMBO™ No.1834R-GR, FUC TOMBO™ No.9090-IOR)

■ JIS F 7102

"Standard for Using Gaskets and Packing for Pipes in Marine Engines" (HUC TOMBO™ No.1834-NA, HUD TOMBO™ No.1834R-NA, KUD TOMBO™ No.1834R-GR)

■ JPI-7S-41 "VORTEX™ Type Gaskets for Piping" (TOMBO™ No.1804-GR series, TOMBO™ No.9090 series)

■ ASME B16.20

[METALLIC GASKETS FOR PIPE FLANGES_RING JOINT, SPIRAL-WOUND, AND JACKETED]

■ API 601(former)

METALLIC GASKETS FOR RAISED FACE PIPE FLANGES AND FLANGED CONNECTIONS (DOUBLE JACKETED CORRUGATED AND SPIRAL-WOUND)

■ BS 3381

METALLIC SPIRAL-WOUND GASKETS FOR USE WITH FLANGES TO BS 1560, PARTS 1 AND 2

■ ISO 7483

DIMENSIONS OF GASKETS FOR USE WITH FLANGES TO ISO 7005



TOMBO™ No. 1841 / 1861

Metal jacketed gaskets

Lineup

Normal type

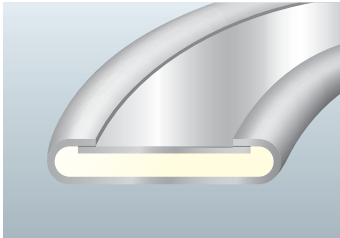

TOMBO™ No. 1841	NA metal jacketed gasket	Core material : Millboard
TOMBO™ No. 1841-FI	NA metal jacketed gasket for high temperature	Core material : Millboard for high temperature
TOMBO™ No. 1841-GR	GR metal jacketed gasket	Core material : Expanded graphite

Corrugated type

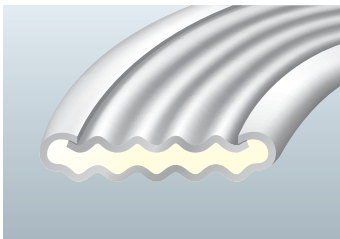

TOMBO™ No. 1861	NA corrugated metal jacketed gasket	Core material : Millboard
TOMBO™ No. 1861-FI	NA corrugated metal jacketed gasket for high temperature	Core material : Millboard for high temperature
TOMBO™ No. 1861-GR	GR corrugated metal jacketed gasket	Core material : Expanded graphite



Metal jacketed gasket with GRASEAL™ tape

This is a metal jacketed gasket with GRASEAL™ (expanded graphite) tape applied to the seal face. (Maximum service temperature: 400°C)



Metal jacketed gasket for heat exchangers

This type of gasket can be manufactured to any desired shape for use in a heat exchanger. Install the gasket in such a way that the face with the turned edges touches the bottom of the groove in the flange.

Understanding TOMBO™ No. When placing an order, indicate the required product specifications (TOMBO™ No.) from those set out below.

TOMBO™ No. **1841** — **FI** — **S** — **GR**

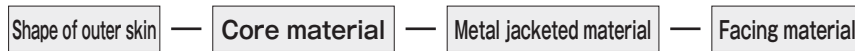

Shape	Indication symbol	Core material	Indication symbol	Metal jacketed material	Indication symbol	Surface material	Indication symbol
Flat	1841	NA mill board	No indication symbol	Carbon steel	S	Expanded graphite	GR
Corrugated	1861	FF sheet	FI	304 stainless steel	E	None	No indication symbol
		Expanded graphite	GR	316 stainless steel	G		
				310S stainless steel	V		
				Aluminum	A		
				Copper	C		
				Alloy 400	M		
				Other than the above	Z		

* Shown at left are the standard materials for cover metal. We can manufacture from other metals according to your specifications.

Maximum service temperature

Core materials	Maximum service temperature
Millboard	530
Millboard for high-temperature	1300
Expanded graphite	400

Cover metal	Maximum service temperature
Carbon steel	535
304 stainless steel	800
316 stainless steel	800
Copper	400
Aluminum	400
310S stainless steel	1150
Alloy 400	800

* Be sure to check the heat-resisting property of both the core material and the cover metal material.

Design criteria

TOMBO™ No.	1841-S	1841-E, 1841-G, others	1841-C	1841-A	1861-S	1861-E, 1861-G, others	1861-C	1861-A
Cover metal material	Carbon steel	304 stainless steel, 316 stainless steel, others	Copper	Aluminum	Carbon steel	304 stainless steel, 316 stainless steel, others	Copper	Aluminum
Gasket coefficient m [-]	3.75	3.75	3.50	3.25	3.00	3.50	3.25	2.50
Minimum design seating stress y [N/mm ²]	52.4	62.1	44.8	38.0	31.0	44.8	38.0	20.0
Minimum seating stress σ_3 [N/mm ²]	Water-type and oil-type fluids	39.2	49.0	34.3	29.4	—	—	—
	Gas-type fluids	101.4	120.4	76.2	58.8	—	—	—

Standard dimensions

Metal jacketed material	Carbon steel	304 stainless steel	316 stainless steel	Copper	Aluminum	310S stainless steel
Material symbol	S	E	G	C	A	V
Standard dimensions [mm]	1480	1180	1180	1180	980	1180

* Indicates the largest diameter of gasket that can be made using a single metal sheet. If a larger gasket is necessary, we will make it by welding two or more metal sheets together.

⚠ Precautions for metal jacketed gasket

Precautions concerning design and selection

● Finish of the gasket seat

The recommended surface roughness when using a metal jacketed gasket is as follows.

- For sealing liquid: 3.2 μm Ra max.
- For sealing gas: 1.6 μm Ra max.

● For 400°C or lower

The sealing face of a metal jacketed gasket is made of metal. If the service temperature is 400°C or lower, the use of the TOMBO™ No.1891 (kammprofile gasket) which has a good fit with the flange and ensures a stable seal is recommended.

● For a standard flange

A standard pipe flange cannot readily acquire adequate tightening force, therefore the use of a metal jacketed gasket is not recommended. If it necessary to use a metal jacketed gasket, the use of one with a hanger rather than a self-centering type is recommended.

Precautions for use

- When using a metal jacketed gasket for a gas-type fluid, use it together with GRASEAL™ (expanded graphite) tape or gasket paste (NEVER-SEEZ™ (service temperature range: -183 to 1425°C), etc.).
- When using a metal jacketed gasket with a T&G type flange, install the gasket so that the face with the turned edges is at the inside of the groove.

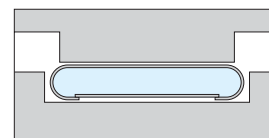





Reference standard

- ASME B16.20
[Metallic Gaskets for Pipe Flanges-Ring-Joint, Spiral-Would, and Jacketed]
(TOMBO™ No.1850C, TOMBO™ No.1850V)

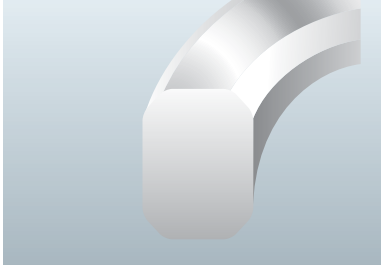

Comparison of metallic gaskets

Metallic Gasket

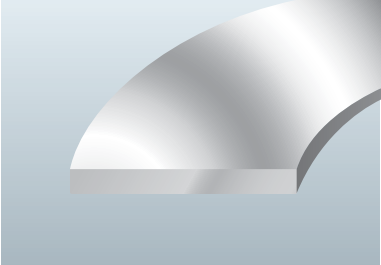
	Product name	Construction	Features	Applications	Service range
	<p>TOMBO™ No.</p> <p>1850C</p> <p>Octagonal ring joint gasket</p>	 	<p>This gasket is made of forged metal that is formed into an octagonal cross-section.</p> <hr/> <ul style="list-style-type: none"> ● The surface-to-surface contact of the gasket sealing face and the flange groove realizes excellent sealing performance. ● The gasket can be reused by re-grinding⁽¹⁾. <p>Note: (1) This involves rubbing the metal surfaces against each other in order to obtain smoother surfaces.</p> <hr/>	<p>This type of gasket is suitable for sealing pipe flanges, valves, pressure vessels, and heat exchangers, etc., under high-temperature and high-pressure conditions, which is difficult to use with a plain type metal gasket.</p> <hr/>	<p>Dependent on the material.</p>
	<p>TOMBO™ No.</p> <p>1850V</p> <p>Oval type ring joint gasket</p>	 	<p>This gasket is made of forged metal formed into an oval cross-section.</p> <hr/> <ul style="list-style-type: none"> ● Compared to an octagonal type, the sealing face of this type of gasket touches the flange along a line, thus provides a good sealing with the flange groove. On the other hand, the ring cannot be reused. <hr/>	<p>Pipe flanges, valves, pressure vessels, heat exchangers, and other applications where sealing is important.</p> <hr/>	<p>Dependent on the material.</p>
	<p>TOMBO™ No.</p> <p>1850P</p> <p>Flat type metallic gasket</p>	 	<p>This is a flat gasket that is cut out from a flat sheet, circular rod, or a forged part, and shaped using a lathe.</p> <hr/> <ul style="list-style-type: none"> ● Flat type gasket made by flat-forming metal. ● A high tightening pressure is necessary to ensure a good sealing between the seal face and the flange. <hr/>	<p>Pipe flanges, valves, pressure vessels, heat exchangers and other places under high-temperature and high-pressure where the flange cannot be formed to the designated shape.</p> <hr/>	<p>Dependent on the material.</p>

These gaskets, which are made of various kinds of metal, are formed to the necessary shape and dimensions for the intended conditions of use.

TOMBO™ No.

1890

Serrated type metallic gasket

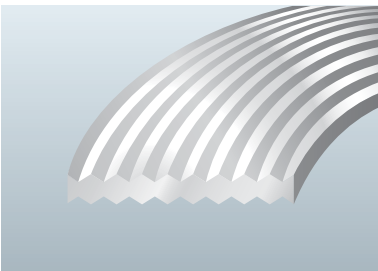

Metallic gasket with concentric serrations on its seating faces.

- Compared to a flat type metallic gasket, the shape of this gasket results in high sealing performance.
- This gasket can withstand the application of concentrated face pressure. On the other hand, it can sometimes damage the flange.

This gasket is used for pipe flanges, valves, pressure vessels, and heat exchangers, etc., where it is necessary to obtain higher sealing performance than that flat type gasket under the same tightening force.

Dependent on the material.

TOMBO™ No.

9200P

Standard type metal O-seal

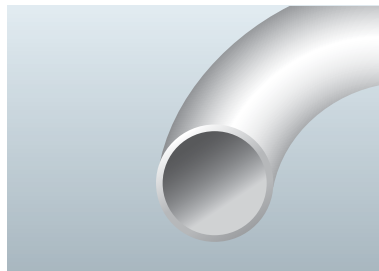

TOMBO™ No.

9200V

Vent hole type metal O-seal

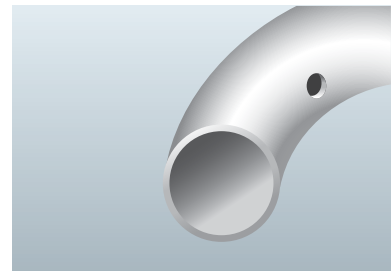

- This gasket is made of a fine metal pipe, which is formed into a circle with its ends welded and its surface finished to a high degree of precision.
- TOMBO™ No.9200V has two or more small holes on its I.D. side (for internal pressure) or O.D. side (for external pressure), through which the fluid enters the ring to increase self-sealing performance.
- This gasket is used by inserting it into a groove and tightening it fully. It can thus provide a high pressure seal with only a small tightening force.

- It has stable, high sealing performance over a wide range of conditions from high temperature to low temperature, and from high pressure to negative pressure.
- When using this gasket in a gas, vacuum or highly volatile fluid, it is recommended that you use a PTFE-coated or silver-plated version.

This gasket is recommended for equipment couplings, forming machines, compression equipment and various engines that require compact design.

- TOMBO™ No.9200P...From a vacuum to fluid of about 7.0MPa
- TOMBO™ No.9200V...High pressure seal of 7.0MPa or higher

Dependent on the material.

Product name

Construction

Features

Applications

Service range

Metallic Gasket



TOMBO™ No. **1850 series / 1890**
Solid metal gasket

■ **Lineup**

We can manufacture octagonal, oval, plain and serrated gaskets, and also metallic gaskets of various shapes.

Shape	Product name	Indication symbol	Features
	RX type ring joint gasket	RX	This is a special octagonal ring joint intended for use on a 6B flange which is stipulated in API spec 6A.
	BX type ring joint gasket	BX	This is a special octagonal ring joint intended for use on a 6BX flange which is stipulated in API spec 6A.
	Delta type metallic gasket	D	This is an auto-seal type metallic gasket that has a triangular cross-section.
	Lens type metallic gasket	L	This is an auto-seal type metallic gasket that has a lens-shaped cross-section. It is stipulated in DIN 2696.
	Double cone type metallic gasket	No indication symbol	This is an auto-seal type metallic gasket the cross section of which is a longitudinally split octagonal ring.
	Bridgeman type metallic gasket	No indication symbol	This is an auto-seal type metallic gasket which has a wedge-shaped cross-section. It is also called a seal ring.

*For shapes other than the above, please contact us.

■ **Understanding TOMBO™ No.** When placing an order, please specify the following product specifications (TOMBO™ No.)

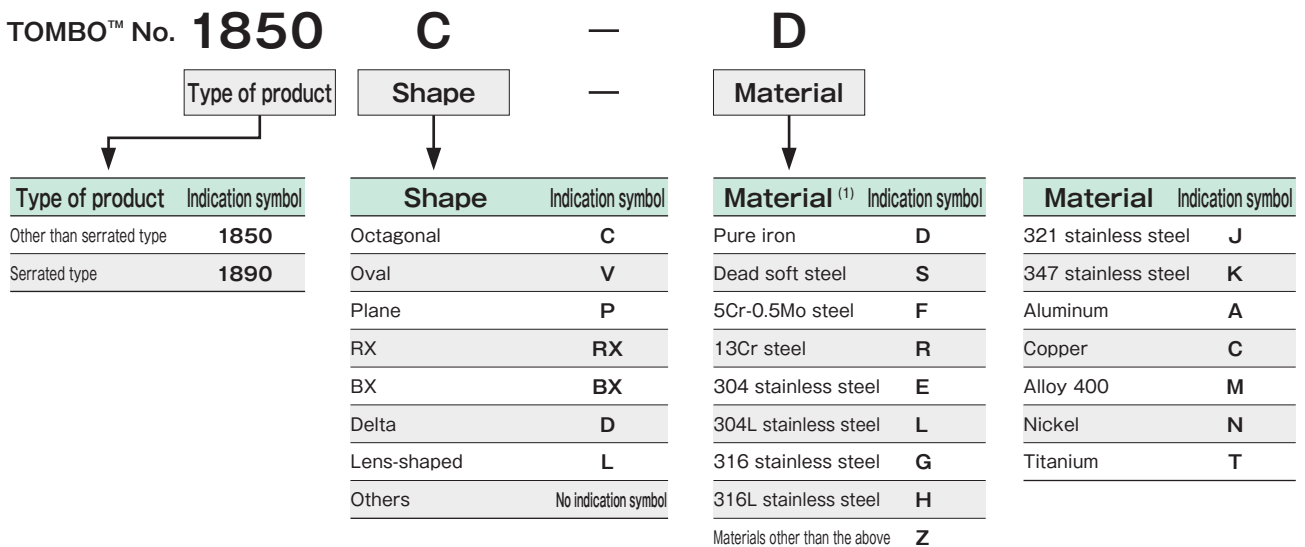

Note : (1) We can manufacture gaskets from other metals according to your specifications. We recommend that you select a gasket that has a Brinell hardness (HB) value of between 30 and 40 softer than that of the flange material.

■ Type of metal and service temperature

Material	Material symbol	Max. service temperature [°C]	Max. hardness ⁽¹⁾	
			HB	HV
Pure iron	D	538	90	—
Dead soft steel	S	538	120	—
5Cr-0.5Mo steel	F	649	130	—
13Cr steel	R	704	170	—
304 stainless steel	E	816	160	—
304L stainless steel	L	816	150	—
316 stainless steel	G	816	160	—
316L stainless steel	H	816	150	—
321 stainless steel	J	816	160	—
347 stainless steel	K	816	160	—
Aluminum	A	300	—	40
Copper	C	400	—	80
Alloy 400	M	800	130	—
Nickel	N	760	120	—
Titanium	T	800	140	—

Note :

(1) In the case of TOMBO™ No.1850P and No.1890, the actual values may differ from those indicated in the table.

*All metallic gaskets are made to order. Regarding the possibility of making a gasket from a material other than those listed in this table, please contact us.

■ Finish of the gasket seat

The recommended surface roughness when using a metal solid gasket is as follows.

- For sealing liquid: 1.6 μm Ra max.
- For sealing gas: 1.6 μm Ra max.

Application standards

■ JPI-7S-23

"Ring joint gaskets and grooves for the petroleum industry"
(TOMBO™ No.1850C, TOMBO™ No.1850V)

■ ASME B16.20



[Metallic Gaskets for Pipe Flanges-Ring-Joint, Spiral-Would, and Jacketed]
(TOMBO™ No.1850C, TOMBO™ No.1850V)

■ API spec 6A

[Wellhead Equipment 6BX Flanges]
(TOMBO™ No.1850C, 1850RX, 1850BX)

Blinds, spacers, and spectacle blinds

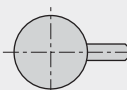
Blinds and spacers are used together with gaskets for blocking pipes or for cutting off pressure during sealing or a pressure resistance test. We also manufacture spectacle blinds which are a combination of a blind and a spacer. In addition, we can also manufacture blinds, spacers and spectacle blinds integrated with ring joint gaskets. Please specify the required material, dimensions, etc.

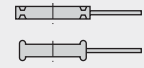
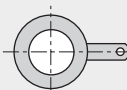
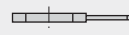
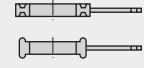
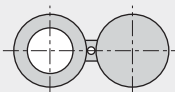
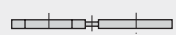
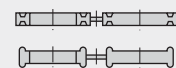
	Shape	RF type	RTJ type
TOMBO™ No.1850-BL Blind			
TOMBO™ No.1850-SP Spacer			
TOMBO™ No.1850-SB Spectacle blind			



TOMBO™ No. 9200 series

Metal O-seal

The sealing of a metal O-seal is by compression force. A vent hole type O-seal provides greater sealing performance due to the fluid that enters the hollow part of the ring, therefore it is recommended that a vent hole type O-seal be used when the pressure is 7MPa or greater.

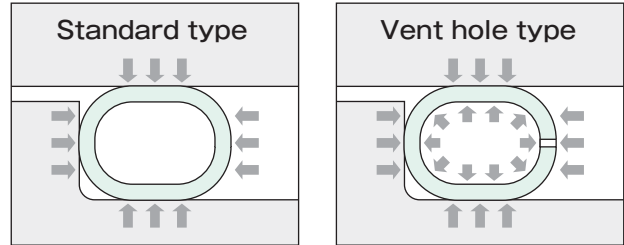

■ Understanding TOMBO™ No. When placing an order, indicate the required product specifications (TOMBO™ No.) from those set out below.

TOMBO™ No. **9200 P** — **J** — **AG**

Shape		Tube material		Surface treatment material	
Shape	Indication symbol	Tube material	Indication symbol	Surface treatment material	Indication symbol
Standard type	P	321 stainless steel	J	None	No indication symbol
Vent hole type	V	Alloy 600	Y	Silver plating	AG
				PTFE coating	TF

[Reference: Old material symbol]

321 stainless steel	321
Alloy 600	In
Silver plating	Ag
PTFE coating	TFE

■ Service range

Tube material ⁽¹⁾	Surface treatment ⁽²⁾	Service temperature range [°C]	Serviceable pressure
321 stainless steel	None	-250~500	High water pressure: 400MPa High-pressure gas: 300MPa Vacuum: 10 ⁻⁴ Pa
	Silver plating	-250~250	
	PTFE coating		
Alloy 600	None	-250~700	
	Silver plating	-250~250	
	PTFE coating		

Note:

(1) A metal O-seal can only be made from 321 stainless steel or Alloy 600.

(2) The surface treatment thickness is between 0.03 and 0.05mm. For sealing a gas, vacuum or volatile fluid, surface treatment is necessary.

■ Tightening criteria

Tube cross-section diameter [mm]	Wall thickness [mm]	Compression load [N/mm]
φ0.8	0.15	69
φ1.6	0.25	118
	0.36	284
φ2.4	0.25	59
	0.46	235
φ3.2	0.25	49
	0.35	88
	0.5	177
φ4.8	0.5	69
	0.8	333
φ6.4	0.8	177

To calculate the actual tightening load, add the load (Wa) of the end force part due to fluid pressure to the load (Wb) calculated from the compression load (Y). The compression load indicates the necessary load for applying the correct tightening force.

■ Calculation of tightening force

$$W = W_a + W_b \\ = \frac{\pi}{4} G^2 P + \pi G Y$$

W: Total bolt load [N]
G: Gasket O.D. [mm]
P: Pressure [MPa]
Y: Compression load [N/mm]

Standard dimensions

Tube cross-section diameter [mm]	Wall thickness [mm]	O.D. dimension [mm]	
		Recommended service range	Manufacturable dimensions
φ0.8	0.15	6 ~ 25	6 ~ 30
φ1.6	0.25	—	12 ~ 200
	0.36	15 ~ 50	11 ~ 200
φ2.4	0.25	—	40 ~ 500
	0.46	40 ~ 200	20 ~ 500
φ3.2	0.25	—	70 ~ 1500
	0.35 ⁽¹⁾	—	60 ~ 1500
	0.5	65 ~ 700	50 ~ 1500
φ4.8	0.5 ⁽¹⁾	—	150 ~ 1500
	0.8	500 ~ 1200	150 ~ 1500
φ6.4	0.8	1000 ~ 1500	250 ~ 1500 ⁽²⁾

Minimum value of the corner radius in the case of a square gasket

For a standard wall thickness (hatched area)

Radius of I.D. side ≥ 6times the O.D. of the tube

For a wall thickness that is less than the standard wall thickness

Radius of I.D. side ≥ 8times the O.D. of the tube

 Indicates the standard wall thickness. For sealing gas, use the standard wall thickness.

 The minimum O.D. of a vent hole type is φ10mm.

 The maximum O.D. of the PTFE coating is φ1300mm. That of silver plating is φ1100.

Note: (1) The only material that can be used to manufacture a tube is SUS321.

(2) If you wish to use a diameter exceeding 1500mm, please consult us.

Groove dimensions

Tube cross-section diameter [mm]	For an internal pressure seal Groove O.D. ⁽¹⁾ [mm]	For an external pressure seal Groove I.D. ⁽¹⁾ [mm]	Groove width (W) ⁽¹⁾ [mm]		Groove depth (H) [mm]	Groove corner rounding (R) [mm]
			Recommended	Min.		
φ0.8	A +0.35 +0.25	(A-1.6) -0.25 -0.35	1.2 min	1.1	0.60 ± 0.05	0.2
φ1.6	A +0.40 +0.30	(A-3.2) -0.30 -0.40	2.4 min	2.0	1.15 ± 0.05	0.3
φ2.4	A +0.40 +0.30	(A-4.8) -0.30 -0.40	3.6 min	2.9	1.75 ± 0.05	0.5
φ3.2	A +0.50 +0.35	(A-6.4) -0.35 -0.50	4.8 min	3.7	2.55 ± 0.05	0.8
φ4.8	A +0.50 +0.35	(A-9.6) -0.35 -0.50	7.2 min	5.6	3.75 ± 0.05	0.8
φ6.4	A +0.55 +0.40	(A-12.8) -0.40 -0.55	9.6 min	7.5	5.00 ± 0.05	0.8

[A = O.D. of gasket]

Note: (1) In the case of a PTFE-coated or silver-plated gasket, the dimensions of the groove will be changed as follows.

- For an internal pressure seal: 0.1mm will be added to the groove O.D., groove width (W) and the groove depth (H).
- For an external pressure seal: 0.1mm will be reduced from the groove I.D., and 0.1mm will be added to the groove width (W) and the groove depth (H).
- If the groove width is narrow, it will be difficult to remove the gasket, so the use of a wide groove width is recommended.

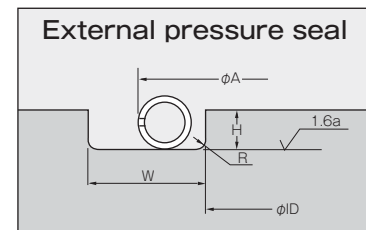
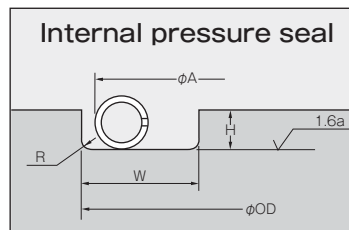

Finish of groove

- For sealing gas or vacuum: 0.8μm Ra max.
- In other cases: 1.6μm Ra max.



Comparison of elastomer gaskets

Product name
Construction
Features
Service range
Lineup

TOMBO™ No. 1050/1051

Elastomer cut gaskets



TOMBO™ No.1050
This gasket is formed by cutting an elastomer sheet into the shape of a gasket.

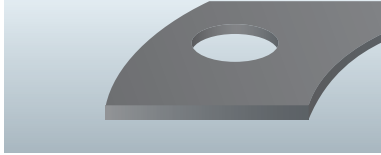

TOMBO™ No.1051
This gasket is formed by cutting an elastomer sheet reinforced with polyester layer into the shape of a gasket.

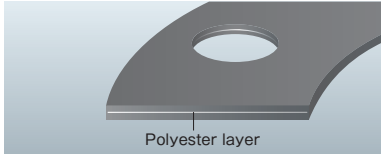

- This gasket utilizes the elasticity, restoring ability and fitting ability of elastomer to realize good sealing performance under low contact pressure.
- * Because TOMBO™ No.1051 is reinforced with a polyester layer, the protrusion from the flange is small. However, this gasket is not suitable as a gas seal, because leakage due to permeation is liable to occur.

Service temperature range Depends on the elastomer material.

Maximum service pressure 1.0MPa

For details of the elastomer materials, see P.58.

For details of the service temperature and standard dimensions, see P.60.

TOMBO™ No. 9013/9013-D

EBILON™ gasket

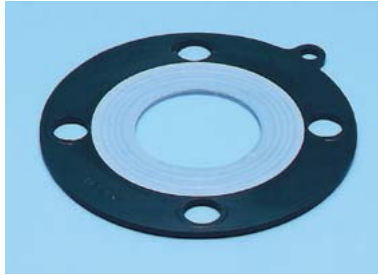

Conforms to the Standards and criteria for food and food additives, etc. (3-D-2. Public Notice No. 370 of the Ministry of Health & Welfare, 1959) stipulated by the Food Sanitation Act
* This applies to PTFE film used on the face that is in contact with the fluid.

This gasket consists of an elastomer core integrated with a pressurized and heat-formed PTFE film.

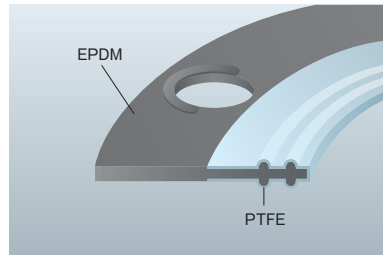

- This gasket combines the elastomer with the corrosion resistance of PTFE, resulting in excellent sealing performance.
- It is ideal for PVC pipes, glass-lined pipes and other applications where a large tightening force cannot be applied.

Service temperature range -30 - 150°C

Maximum service pressure 2.0MPa

Flange shape Full face

TOMBO™ No.9013
Consists of EPDM covered with PTFE.

TOMBO™ No.9013-D
Consists of special EPDM for an electrolytic tank. Covered with PTFE.

TOMBO™ No. 9013-EP/-DEP

EBILON™ gasket



Elastomer gasket pressure-formed to the shape shown below.

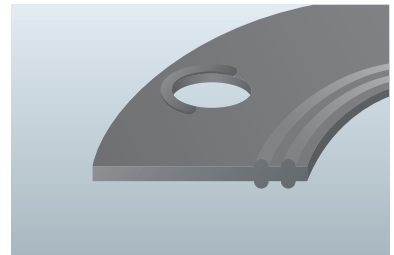

- This gasket realizes stable sealing performance under a lower contact pressure than that of an elastomer cut gasket.
- * This gasket is recommended for use at places where the service conditions are not harsh, and there is not much need for chemical resistance.

Service temperature range -30 - 150°C

Maximum service pressure 1.0MPa

Flange shape Full face

TOMBO™ No.9013-EP
EPDM

TOMBO™ No.9013-DEP
Special EPDM for an electrolytic tank

For details of standard dimensions, see P.60.

These gaskets consist mainly of elastomer. Consequently, they feature good sealing with the flange, even under low tightening pressure.

TOMBO™ No.

9014-B/BW

SANICLEAN™ gaskets for ferrules



Conforms to the Standards and criteria for food and food additives, etc. (3-D-2, Public Notice No. 370 of the Ministry of Health & Welfare, 1959) stipulated by the Food Sanitation Act

* This applies to PTFE film used on the face that is in contact with the fluid.

TOMBO™ No.

9014-A

SANICLEAN™ gaskets for screw coupling



TOMBO™ No.

2670/2675

Elastomer O-rings/BLAZER™ O-rings



This sandwiched type combination gasket is an elastomer sanitary gasket covered with PTFE film, realizing excellent resistance against chemicals, heat, and contamination.

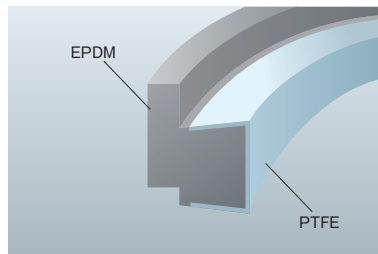
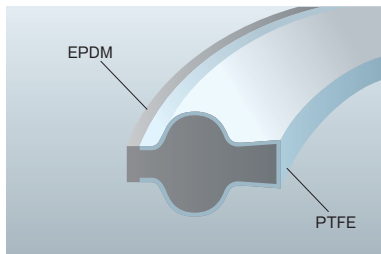

- Because the entire face in contact with the fluid is made of PTFE⁽¹⁾, the surface is not degraded by hot water, hot caustic fluid, or chlorine water used in a sanitation⁽²⁾ process.
- Because the entire face in contact with the fluid is made of PTFE, there is little adhesion or penetration of liquid, so these gaskets are effective for preventing contamination of flavor during a flavor change⁽³⁾.
- The use of these gaskets reduces the duration of the sanitation process during a flavor change, contributing to improved productivity.

* The method of using these gaskets is basically the same as conventional elastomer sanitary gasket, and is easy, however it is necessary to carry out additional tightening work.

Note: (1) PTFE used on the fluid contact surface of TOMBO™ No.9014 (SANICLEAN™ gasket) has passed the elution test for plastic implement, container and package specified in 3-D-2 of the standard covering foodstuffs and additives, etc. (Public Notice No.370, 1959).

(2) Sanitation: This is cleaning work carried out using tap water, chlorine water, hot water or hot caustic fluid.

(3) Flavor change: This is a change of a production item on a beverage production line, such as a product filler line, which is shared among several kinds of beverages.

Service temperature range -30 - 150°C

Maximum service pressure 1.0MPa

TOMBO™ No.9014-B for ferrule Black EPDM

TOMBO™ No.9014-BW for ferrule White EPDM

For details of standard dimensions, see P.61.

Elastomer O-rings are manufactured from various kinds of elastomer using a die.

- These elastomer O-rings provide a good sealing, even under a small tightening force, and can provide a seal from a vacuum to a high pressure of about 25MPa.
- In addition to their use as shaft seals (packing), these elastomer O-rings can be inserted into a groove and used as gaskets.

Service temperature range Depends upon the elastomer material.

Maximum service pressure 25MPa

* These O-rings can also be used at pressures above 25MPa, provided that consideration is given to clearances, backup rings, etc.

For details of the elastomer materials, see P.61.

For details of standard dimensions and basic physical properties, see P.61.

Product name

Construction

Features

Service range

Lineup

Elastomer Gaskets



TOMBO™ No. 1050 / 1051

Elastomer cut gaskets

Standard dimensions

Thickness [mm]	Width [mm]	Max. O.D. [mm]
1.0	1,000	φ1,000
1.5		
2.0		
3.0		
5.0		
10.0		

* The minimum thickness of a cloth-reinforced NR gasket is 1.5mm.

Design standard

TOMBO™ No.	1050 (HS ⁽¹⁾ less than 75)	1050 (HS ⁽¹⁾ 75 or more)	1051
Gasket coefficient m [-]	0.50	1.00	1.25
Minimum design seating stress γ [N/mm ²]	0.0	1.4	2.8
Minimum seating stress σ_3 [N/mm ²]	Water-type and oil-type fluids	2.0	2.9
	Gas-type fluids	2.0	—
Allowable seating stress [N/mm ²]	14.7	14.7	14.7

Note: (1) Hardness of elastomer (by Type A durometer)

Finish of gasket seat

The recommended surface roughness for a elastomer cut gasket is as follows.

- For sealing liquid: 25 μ m Ra max.
- For sealing gas: 25 μ m RA max.

Standard materials

Material	Material symbol	Service temperature range [°C]	TOMBO™ No.	
			1050	1051
Nitrile elastomer (oil resistance)	NBR	-30 ~ 120	●	●
Chloroprene elastomer (weather resistance)	CR	-30 ~ 120	●	●
Ethylene-propylene elastomer (weather resistance and vapor resistance)	EP	-40 ~ 150	●	—
Butyl elastomer (weather resistance, acid resistance and vapor resistance)	IIR	-30 ~ 150	●	—
Silicone elastomer (weather resistance and cold resistance)	SI	-60 ~ 230	●	—
Fluoro elastomer (heat resistance)	FA	-15 ~ 200	●	—
Fluoro elastomer (corrosion resistance)	FS	0 ~ 200	●	—
Natural elastomer	NR	-20 ~ 100	●	●



TOMBO™ No. 9013 series

EBILON™ gaskets

Standard dimensions

- Plastic flange (equivalent to JIS 10K) 15A to 300A
- JPI class 150 1/2 - 12B

Finish of gasket seat

The recommended surface roughness for an EBILON™ gasket is as follows.

- For sealing liquid: 25 μ m Ra max.
- For sealing gas: 25 μ m Ra max.

* The surface roughness of the seat on a steel flange is 6.3 μ m Ra.



TOMBO™ No. 9014 series

SANICLEAN™ gaskets

Standard dimensions

Nominal dimension [inch]	TOMBO™ No.					
	9014-A (for screw coupling) [mm]			9014-B (for ferrule) [mm]		
	φA	φB	φC	φA	φB	φC
1	32.5	29.2	23.0	49.5	43.5	23.1
1 1/2	46.0	42.7	35.6	49.5	43.5	35.8
2	59.5	56.2	47.8	63.0	56.5	48.0
2 1/2	73.0	69.9	59.5	76.5	70.5	59.7
3	86.5	82.6	72.1	90.0	83.5	72.3
4	112.5	108.3	97.6	118.0	110.0	97.8

* The standard dimensions of TOMBO™ No.9014-A, B and BW are determined based on the IDF standard. It can also be used for screw couplings and clamp type couplings stipulated by ISO2852 and ISO2853.

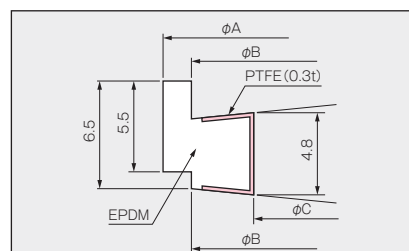

TOMBO™ No.9014-A (for screw coupling)

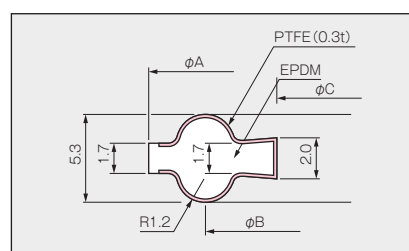

TOMBO™ No.9014-B and BW (for ferrule)



TOMBO™ No. 2670 / 2675

Elastomer O-rings

Standard dimensions

- JIS B 2401 "O-rings," ● AS 568B "Aerospace size standards for O-rings," ● JIS B 8365 "Dimensions of Clamped-type Vacuum Couplings"

Service temperature and basic physical properties

ASTM code		FFKM			Special FKM		FKM		Q	EPDM	CR	NBR
Product name		BLAZER™ next	BLAZER™ A	BLAZER™ S2	BLAZER™ FC	BLAZER™ FE	Fluoro elastomer FB	Fluoro elastomer FA	Silicone elastomer	Ethylene- propylene elastomer	Chloroprene elastomer	Nitrile elastomer
Material symbol		BNX	A	S2	FC	FE	FB	FA	SI	EP	CR	NBR
Features		Heat-resistance	Chemical-resistance	Vapor-resistance	Plasma-resistance	Plasma-resistance	Acid-resistance and vapor-resistance	Heat-resistance	Heat-resistance	Weather-resistance and water-resistance	Weather-resistance and oil-resistance	Mineral oil-resistance
JIS class		—	—	—	—	—	—	FKM-70	VMQ-70	EPDM-70	—	NBR-70
Color tone		Black	Black	Black	Black	Black	Black	Black	Reddish brown	Black	Black	Black
Service temperature range (rough guide) [°C]		0~335	0~210	0~320	0~200	0~200	0~200	-15~200	-50~200	-40~150	-30~120	-30~120
Physical properties in normal state	Hardness measured using a type A durometer	76	75	80	60	60	70	69	70	70	67	68
	Tensile strength [MPa]	11.1	13.1	15.3	18.8	11.4	15.7	15.3	6.3	15.3	12.8	16.4
	Elongation [%]	140	150	198	210	230	460	300	260	280	260	300
	Tensile stress [at 100% elongation]	8.3	6.4	15.6	3.9	3.5	2.8	3.3	—	—	4.2	3.0
Compression set property	Temperature × Time [°C] × [hrs]	300×72	150×72	300×72	100×72	100×72	175×24	200×72	175×72	100×72	100×72	120×72
	Compression set [%]	26	20	45	9	9	20	22	27	8	29	13
Aging resistance	Temperature × Time [°C] × [hrs]	—	—	—	—	—	230×24	230×24	230×72	100×72	100×72	120×72
	Change of hardness measured using a type A durometer	—	—	—	—	—	0	+1	-6	+1	+9	+4
	Tensile strength rate of change [%]	—	—	—	—	—	-13.0	-5	-8	+9	+8	-3
	Elongation rate of change [%]	—	—	—	—	—	-6.0	0	-23	+4	-23	-29

* In addition to the above, butyl elastomer (IIR), hydrogen added nitrile elastomer (ZR) are also available.

* The table above indicates the general physical properties of elastomer O-rings. For more details, please refer to the "Elastomer O-rings" catalog.



Comparison of cloth gaskets

These gaskets are not suitable for tight gas seals. Use them in places where a certain amount of leakage is permitted.

Product name

TOMBO™ No.
1374
NA manhole gasket

TOMBO™ No.
1400-TH
FF manhole gasket

TOMBO™ No.
1400-NA/-S
Super manhole series

TOMBO™ No.
1400-ST
Super manhole series

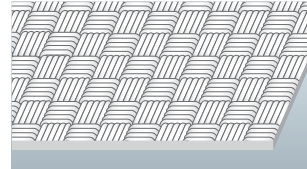

These gaskets consist of heat resistant cloth which is caulked with rubber filler and then cut to the specified shape.

TOMBO™ No.		1374	1400-TH	1400-NA	1400-ST	1400-S
Cloth construction	Wefe	Glass fiber	Ceramic fiber + SUS wire	Glass fiber	Ceramic fiber + SUS wire	Ceramic fiber + SUS wire
	Warp	Glass fiber	Ceramic fiber + SUS wire	SUS wire	Ceramic fiber + SUS wire	SUS wire
Heat-resistant temperature [°C]		400	600		800	
Color tone		Gray	Yellow	Black	Yellow	Gray
Smoke emission ⁽¹⁾ (quantity of organic matter)		25% or less	20% or less	15% or less	25% or less	15% or less

* This is a measured value. It is not a guaranteed value.

Features

Handling

TOMBO™ No.		1374	1400-TH	1400-NA	1400-ST	1400-S
Hardness/softness	Evaluation	Soft	Soft	Hard	Soft	Soft
	Compression [%] ⁽¹⁾	59	70	34	70	58
Stiffness	Evaluation	Strong	Weak	Very strong	Strong	Strong
	Deflection [mm] ⁽²⁾	18	36	1	19	15
Tensile strength	Evaluation	Strong	Weak	Very strong	Somewhat weak	Somewhat strong
	Tensile strength ⁽³⁾	282N	60N	568N	74N	109N

Note: (1) Degree of compression when a contact pressure of 5.9MPa is applied.
(2) Fix a testpiece of 20mm × 200mm at one point, and measure the deflection when the test piece is allowed to droop under its own weight.
(3) Tensile strength per one piece of cloth.

* This is the measured value. It is not a guaranteed value.

Applications

Manholes and hand holes for exhaust gas, hot air passage, etc. Autoclaves and large bore flanges.
Diesel engine exhaust pipe, flue manhole, boiler combustion port.

Lineup

TOMBO™ No. 1374-G
This gasket consists of TOMBO™ No.1374 that has been subjected to anti-seizure treatment (graphite treatment). Black.

TOMBO™ No. 1400-THG
This gasket consists of TOMBO™ No.1400-TH that has been subjected to anti-seizure treatment (graphite treatment). Black.

TOMBO™ No.9094 NAFLON™ manhole gasket
This is a manhole gasket that uses PTFE dispersion as the filler material. It is used for the ducts where chemical resistance or solvent resistance is required and the ducts for corrosive gas such as acidic exhaust gas. It withstands a temperature of 300°C. Color: White

Woven gaskets are divided mainly into two types. One is a tape type consisting of woven cloth coated with rubber compound that is folded into several layers and pressed into the form of a tape. The other is a manhole type consisting of woven cloth sewn to fit the shape of the manhole and then formed into a gasket. They are ideal for applications in which the bore of the flange is large, where there is distortion, and also where a high seating stress cannot be applied.

TOMBO™ No.

1364

NA gasket tape

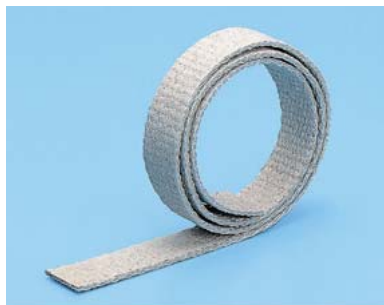

This gasket tape consists of woven glass cloth coated with natural rubber and folded to form a laminated tape.

3-layer fold 4-layer fold



400°C

Gray

Manholes, hand holes, autoclaves and large bore flanges that are exposed to low pressure vapor, exhaust gas, hot air, etc.

TOMBO™ No.

1368

NA tadpole gasket tape

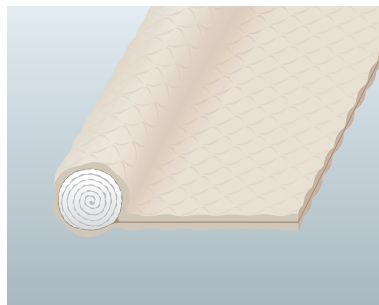

■ TOMBO™ No.1368 gasket tape has a core of woven glass cloth coated with rubber compound and coiled, and its outer skin is formed as shown in the figure above.

■ TOMBO™ No.1378 is TOMBO™ No.1368 that is formed into a ring and sewn into the shape of a gasket.

400°C

Gray

Doors of furnaces, heaters, dryers, etc., dampers, and also manholes for passages of exhaust gas, hot air, dust, etc.

■ TOMBO™ No.1368-G

This is TOMBO™ No.1368 subjected to anti-seizure treatment (graphite treatment). Black.

TOMBO™ No.

1378

NA tadpole gasket



Product name

Series description

Color tone

Applications

Lineup



Cloth Gasket

■ Standard dimensions

TOMBO™ No.		1374 1374-G	1400-TH 1400-THG	1400-ST	1400-NA	1400-S	9094	1364	1368 1368-G	1378	
Nominal thickness	1.6	—	—	—	—	—	●	—	—	—	
	2.5	—	—	●	—	—	—	—	—	—	
	3.0	—	—	—	—	●	—	—	—	—	
	3.2	●	—	—	●	—	●	●	●	●	
	4.0	—	●	—	—	—	—	—	—	—	
	4.8	●	—	—	●	—	●	●	—	—	
	5.0	—	—	●	—	●	—	—	—	—	
	6.0	—	●	—	—	●	—	—	—	—	
	6.4	●	—	—	●	—	●	●	—	—	
	7.5	—	—	●	—	—	—	—	—	—	
	8.0	●	●	—	●	●	—	—	—	—	
	9.6	●	—	—	—	●	—	—	—	—	
10.0	—	●	●	—	—	●	—	—	—		
Dimensions		Please specify.					Please specify.		[Width mm] 13, 20, 25, 30, 40, 50 [Length m]30	[Height mm] 6.4, 7.9, 9.5, 11.1, 12.7, 15.9, 19.1, 22.2, 25.4	Please specify.



Comparison of pastes and other sealing materials

	TOMBO™ No. 9105 AQUA-TIGHT™ Paste	TOMBO™ No. 9106 OIL-TIGHT™ Paste	TOMBO™ No. 9400 NAFLON™ Paste
Product name			
Features	This gasket paste is suitable for a water-type fluid. It consists of fine mica powder blended with a special oil-soluble binder.	This gasket paste is suitable for use with oil-type fluids. It consists of fine mica powder blended with a water-soluble binder which is highly resistant to oil and solvents.	<ul style="list-style-type: none"> ● This gasket paste, which is inert at normal temperature, consists of a colloidal suspension of fluororesin particles dispersed in water. ● This versatile paste has excellent chemical resistance, and can be used for acidic fluids and corrosive fluids.
Applications	Water-type fluids such as water, steam, hot water, seawater, acids, alkalis, and saline solutions	Petroleum-based oil, oil gas, solvents, solvent vapor, animal and mineral oil, hydrocarbon-based fluids, exhaust gas, etc.	Various water-type fluids, various oil-type fluids, acidic fluids, corrosive fluids, and vacuum seals.
Color	Cream	Cream	White
Service range	-200°C - 200°C	-200°C - 900°C	~ 260°C
Coverage	Approx. 200g/m ² (12.5m ² /can)	Approx. 300g/m ² (8.3m ² /can)	Approx. 50g/m ² (2m ² /tube)
Package	2.5kg polyethylene container	2.5kg polyethylene container	65cc (approx. 100g) tube 700cc (approx. 1kg) polyethylene container

⚠ Precautions for using gasket paste

- Gasket paste is intended to assist the sealing function of a gasket. It is not intended to be used on its own. Be sure to use it by applying it to a gasket.
- Before using gasket paste that comes in a container, agitate it thoroughly.
- Spread gasket paste thinly and apply it using a brush, shop towel, etc. If you apply too much paste, the gasket may become damaged.
- When using gasket paste for the purpose of improving the gas sealing performance of a jointing sheet, apply the gasket paste to the I.D. side in order to prevent gas leakage due to penetration.
- Set the gasket on the flange before the gasket paste has completely dried.
- After use, close the container securely and store in a cool and dark location.
- There is a possibility of elution of a minute quantity of paste particles. Do not use gasket paste in applications such as foodstuff where even a minute quantity of elution is not tolerated.

■ Guide to the suitability of gasket paste

Product	TOMBO™ No. (example)	Gas	Liquid	Applicable paste (TOMBO™ No.)
Joint sheet	1120	○	×	9105
	1995	○	×	9106
				9400
Fluororesin gasket	9007-SC	○	×	9400
	9007-LC	○	×	
	1133	○	×	
GRASEAL™ gasket	1200 series	▲	▲	—
VORTEX™ gasket	1834-GR series	×	×	—
	1834R-NA series	×	×	—

○ Recommended.

▲ When high gas sealing performance is required, use TOMBO™ No.1215-T.

× Paste is not required. (However, it can be used.)

* On a gasket using expanded graphite, if paste containing metal, such as Never-Seez, is used at high temperature, the expanded graphite may be lost by oxidation due to the catalytic action of the paste components.

TOMBO™ No.

9401

Fluorine grease



This type of grease consists of fluorine resin oil to which chemically inert highly heat resistant fine powder macromolecular material has been added.

Oxygen, corrosive fluids, vacuum seal

White

~ 150°C

Approx. 50g/m² (1m²/tube)

50g tube

TOMBO™ No.

9082/9082-BL

NAFLON™ PTFE thread seal tape



- This product consists of unsintered PTFE that is extruded by an extruder and rolled into the form of tape.
- It is very soft, so it enables a seal of a complicated shape to be easily made. It does not contaminate the fluid, can be removed easily, and has excellent workability.

* When using this tape on a screw coupling, be sure to use it on a tapered thread.

Screw coupling for various fluids other than combustible gases and toxic gases

* Do not use this seal tape for combustible gases or toxic gases.

Service range

-200~260°C

* The service range is a rough guide. The range differ according to the condition of use.

Standard dimensions

Thickness 0.1mm

Width 13mm

Length 5m / 15m

This tape is wound on a plastic reel. It comes in a box containing 10rolls.

Lineup

TOMBO™ No.9082

Apparent density[g/cm³] 1.0 or more, but less than 1.4

Tensile strength[N/mm²] 6.9 ~ 15.7

TOMBO™ No.9082-BL

Apparent density[g/cm³] 0.75 or more, but less than 1.15

Tensile strength[N/mm²] 4.9 ~ 12.7

TOMBO™ No.

1600

METAKOTE™



- This gasket consists of a thin metal sheet that is lightly coated on both sides with rubber, and surface-treated with graphite.
- It has high thickness and dimensional accuracy, and there is no substantial leakage.
- The amount of stress reduction is small, so there is no need to perform additional tightening.

Gaskets and sealing washers for hydraulic equipment, pneumatic equipment, equipment related to automobiles, and compressors for chillers

Maximum service temperature

~180°C

Features

Applications

Paste and other sealing materials

TOMBO™ BRAND GASKETS

Dimension Tables / Basic Items Concerning Gaskets

■ Dimension Tables

Sheet gaskets	68 – 77
VORTEX™ gaskets	78 – 93
Metallic gaskets	94 – 98
Envelope gaskets	99 – 111
Rubber gaskets	112 – 113

■ Basic Items Concerning Gaskets

Gasket tightening criteria	114 – 115
Introduction of JIS B 2251-2008 Bolt tightening for pressure boundary flanged joint assembly	115
Gasket design criteria list	116 – 117
Gasket standard dimension list	118 – 119

For JIS pipe flanges

Soft gaskets / ring gaskets (F.R.)

■ Applicable gaskets

Joining sheets, fluoropolymer gaskets, GRASEAL™ gaskets, cut rubber gaskets, cloth reinforced rubber cut gasket

■ Applicable standards

JIS B 2404-2006 "Dimensions of Gaskets for Use with Pipe Flanges," Appendix Table 4 Dimensions

(Old) JIS B 2238-1996 "General Rules for Steel Pipe Flanges," Reference Tables 2 and 3

(Old) JIS B 2404-1999 "Dimensions of Gaskets for Use with Pipe Flanges," Table 7

■ Applicable flanges

JIS B 2220-2012 "Steel Pipe Flanges"

(Old) JIS B 2238-1996 "General Rules for Steel Pipe Flanges"

JIS B 2239-2004 "Cast Iron Pipe Flanges"

(Old) JIS B 2240-1996 "General Rules for Copper Alloy Pipe Flanges"

JIS B JIS B 2240-2006 "Copper Alloy Pipe Flanges"

(Old) JIS B 2241-1986 "Basic Dimensions of Aluminium Alloy Pipe Flanges"

JIS B 2241-2006 "Aluminium alloy pipe flanges"

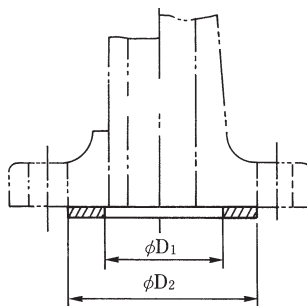

For full-face seat flange

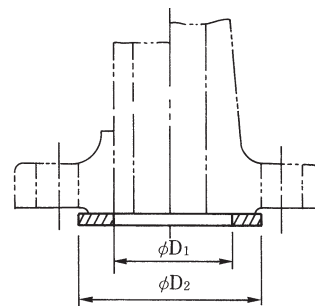

For large flat seat flange

[Dimension Table 1]

Unit [mm]

Nominal flange diameter	I.D. of gasket D ₁	For full-face seat, large flat seat, and small flat seat flanges									
		Gasket O.D. D ₂							Nominal pressure 30K	Nominal pressure 40K	Nominal pressure 63K
		Nominal pressure 2K	Nominal pressure 5K	Nominal pressure 10K	Thin flange nominal pressure 10K	Nominal pressure 16K	Nominal pressure 20K				
10A	18	—	45	53	55	53	53	59	59	64	
15	22	—	50	58	60	58	58	64	64	69	
20	28	—	55	63	65	63	63	69	69	75	
25	35	—	65	74	78	74	74	79	79	80	
32	43	—	78	84	88	84	84	89	89	90	
40	49	—	83	89	93	89	89	100	100	108	
50	61	—	93	104	108	104	104	114	114	125	
65	84 (77)	—	118	124	128	124	124	140	140	153	
80	90	—	129	134	138	140	140	150	150	163	
90	102	—	139	144	148	150	150	163	163	181	
100	115	—	149	159	163	165	165	173	183	196	
125	141	—	184	190	194	203	203	208	226	235	
150	167	—	214	220	224	238	238	251	265	275	
175	192	—	240	245	249	—	—	—	—	—	
200	218	—	260	270	274	283	283	296	315	330	
225	244	—	285	290	294	—	—	—	—	—	
250	270	—	325	333	335	356	356	360	380	394	
300	321	—	370	378	380	406	406	420	434	449	
350	359	—	413	423	425	450	450	465	479	488	
400	410	—	473	486	488	510	510	524	534	548	
450	460	535	533	541	—	575	575	—	—	—	
500	513	585	583	596	—	630	630	—	—	—	
550	564	643	641	650	—	684	684	—	—	—	
600	615	693	691	700	—	734	734	—	—	—	
650	667	748	746	750	—	784	805	—	—	—	
700	718	798	796	810	—	836	855	—	—	—	
750	770	856	850	870	—	896	918	—	—	—	
800	820	906	900	920	—	945	978	—	—	—	
850	872	956	950	970	—	995	1,038	—	—	—	
900	923	1,006	1,000	1,020	—	1,045	1,088	—	—	—	
1,000	1,025	1,106	1,100	1,124	—	1,158	—	—	—	—	
1,100	1,130	1,216	1,210	1,234	—	1,258	—	—	—	—	
1,200	1,230	1,326	1,320	1,344	—	1,368	—	—	—	—	
1,300	1,335	—	—	—	—	1,474	—	—	—	—	
1,350	1,385	1,481	1,475	1,498	—	1,534	—	—	—	—	
1,400	1,435	—	—	—	—	1,584	—	—	—	—	
1,500	1,540	1,636	1,630	1,658	—	1,694	—	—	—	—	

*The dimension in parentheses [] and unstipulated nominal pressure values of 2K, 40K and 63K are the same as those in (Old) JIS B 2238-1996 "General Rules for Steel Pipe Flanges" Reference Tables 2 and 3 and (Old) JIS B 2404-1999 "Dimensions of Gaskets for Use with Pipe Flanges" Table 7.

*Bold border □: It may sometimes be impossible to apply adequate tightening force to joining sheets, GRASEAL™ gaskets and PTFE cut gaskets, so we do not recommend that they be used at nominal pressure values of 2K and 5K, as a general rule. Rubber cut gaskets and cloth reinforced gaskets are recommended.

*Double border □: We do not recommend soft gaskets for a nominal pressure of 30K or more, as a general rule. Semi-metallic gaskets are recommended.

For JIS pipe flanges

Soft gaskets / full-face gaskets (F.F.)

■ **Applicable gaskets**

Joining sheets, fluoropolymer gaskets, GRASEAL™ gaskets, cut rubber gaskets, cloth reinforced rubber cut gaskets

■ **Applicable standards**

JIS B 2404-2006 "Dimensions of Gaskets for Use with Pipe Flanges," Appendix Tables 1, 2, 3 Dimensions
 (Old) JIS B 2404-1999 "Dimensions of Gaskets for Use with Pipe Flanges," Table 6

■ **Applicable flanges**

JIS B 2220-2012 "Steel Pipe Flanges"
 (Old) JIS B 2238-1996 "General Rules for Steel Pipe Flanges"
 JIS B 2239-2004 "Cast Iron Pipe Flanges"
 (Old) JIS B 2240-1996 "General Rules for Copper Alloy Pipe Flanges"
 JIS B 2240-2006 "Copper Alloy Pipe Flanges"
 (Old) JIS B 2241-1986 "Basic Dimensions of Aluminium Alloy Pipe Flanges"
 JIS B 2241-2006 "Aluminium alloy pipe flanges"

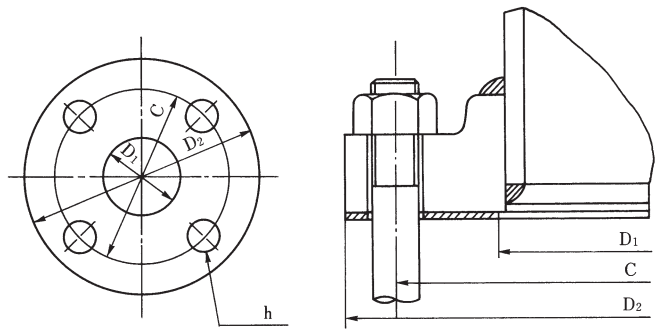

[Dimension Table 2]

Unit [mm]

Nominal flange diameter	I.D. of gasket D ₁	Nominal pressure 2K			5K			10K			16K		
		O.D. of gasket D ₂	Pitch circle diameter C	n x h	O.D. of gasket D ₂	Pitch circle diameter C	n x h	O.D. of gasket D ₂	Pitch circle diameter C	n x h	O.D. of gasket D ₂	Pitch circle diameter C	n x h
10A	18	—	—	—	75	55	4×12	90	65	4×15	90	65	4×15
15	22	—	—	—	80	60	4×12	95	70	4×15	95	70	4×15
20	28	—	—	—	85	65	4×12	100	75	4×15	100	75	4×15
25	35	—	—	—	95	75	4×12	125	90	4×19	125	90	4×19
32	43	—	—	—	115	90	4×15	135	100	4×19	135	100	4×19
40	49	—	—	—	120	95	4×15	140	105	4×19	140	105	4×19
50	61	—	—	—	130	105	4×15	155	120	4×19	155	120	8×19
65	84 (77)	—	—	—	155	130	4×15	175	140	4×19	175	140	8×19
80	90	—	—	—	180	145	4×19	185	150	8×19	200	160	8×23
90	102	—	—	—	190	155	4×19	195	160	8×19	210	170	8×23
100	115	—	—	—	200	165	8×19	210	175	8×19	225	185	8×23
125	141	—	—	—	235	200	8×19	250	210	8×23	270	225	8×25
150	167	—	—	—	265	230	8×19	280	240	8×23	305	260	12×25
175	192	—	—	—	300	260	8×23	305	265	12×23	—	—	—
200	218	—	—	—	320	280	8×23	330	290	12×23	350	305	12×25
225	244	—	—	—	345	305	12×23	350	310	12×23	—	—	—
250	270	—	—	—	385	345	12×23	400	355	12×25	430	380	12×27
300	321	—	—	—	430	390	12×23	445	400	16×25	480	430	16×27
350	359	—	—	—	480	435	12×25	490	445	16×25	540	480	16×33
400	410	—	—	—	540	495	16×25	560	510	16×27	605	540	16×33
450	460	605	555	16×23	605	555	16×25	620	565	20×27	675	605	20×33
500	513	655	605	20×23	655	605	20×25	675	620	20×27	730	660	20×33
550	564	720	665	20×25	720	665	20×27	745	680	20×33	795	720	20×39
600	615	770	715	20×25	770	715	20×27	795	730	24×33	845	770	24×39
650	667	825	770	24×25	825	770	24×27	845	780	24×33	—	—	—
700	718	875	820	24×25	875	820	24×27	905	840	24×33	—	—	—
750	770	945	880	24×27	945	880	24×33	970	900	24×33	—	—	—
800	820	995	930	24×27	995	930	24×33	1,020	950	28×33	—	—	—
850	872	1,045	980	24×27	1,045	980	24×33	1,070	1,000	28×33	—	—	—
900	923	1,095	1,030	24×27	1,095	1,030	24×33	1,120	1,050	28×33	—	—	—
1,000	1,025	1,195	1,130	28×27	1,195	1,130	28×33	1,235	1,160	28×39	—	—	—
1,100	1,130	1,305	1,240	28×27	1,305	1,240	28×33	1,345	1,270	28×39	—	—	—
1,200	1,230	1,420	1,350	32×27	1,420	1,350	32×33	1,465	1,380	32×39	—	—	—
1,350	1,385	1,575	1,505	32×27	1,575	1,505	32×33	1,630	1,540	36×45	—	—	—
1,500	1,540	1,730	1,660	36×27	1,730	1,660	36×33	1,795	1,700	40×45	—	—	—

*The values for the nominal pressure of 2K are the same as in JIS B 2404-1999 "Dimensions of Gaskets for Use with Pipe Flanges" Table 7.
 *Bold border □: It may sometimes be impossible to apply adequate tightening force to joining sheets. GRASEAL™ gaskets and PTFE cut gaskets, so we do not recommend that they be used at nominal pressure values of 2K and 5K, as a general rule. Rubber cut gaskets and cloth reinforced gaskets are recommended.
 *Double border □: It is difficult to seal gas, even for nominal diameters of 10K and 16K.

For JPI pipe flanges and JPI large bore flange series B

Soft gaskets / ring gaskets (F.R.) Group I

■ **Applicable gaskets**

Joining sheets, fluoropolymer gaskets, GRASEAL™ gaskets, rubber cut gaskets, cloth reinforced rubber cut gaskets

■ **Applicable standard**

JPI-7S-16-2014 "Dimensions of Non-metallic Gaskets for Pipes," Appendix Tables 1, 3, 10, 11 and 12 and Reference Appendix Table 1 Dimensions

■ **Applicable flanges**

JPI-7S-15-99 "Flanges for the Petroleum Industry"
 JPI-7S-43-01 (Series B) "Large Bore Flanges for the Petroleum Industry"
 ASME B 16.5 "Pipe Flanges and Flanged Fittings"
 ANSI B 16.5 "Steel pipe Flange"
 ASME B 16.47-1996 (series B) "Large Diameter Steel Flanges"
 API-Std 605-1980 "Large-Diameter Carbon Steel Flanges"

Slip-on welded type (socket-welded type) flange dimensions can also be used on a TAYLOR FORGE flange.

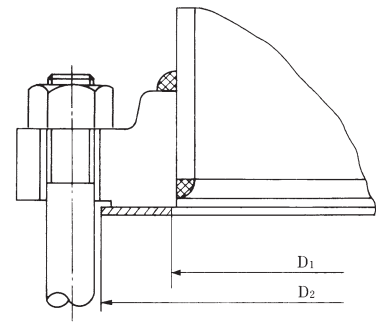

[Dimension Table 3]

Unit [mm]

Nominal flange diameter		For flat seat flange						For large bore slip-on welded type flange			
		Class 75		Class 150		Class 300		Class 175		Class 350	
A	B	I.D. D ₁	O.D. D ₂	I.D. D ₁	O.D. D ₂	I.D. D ₁	O.D. D ₂	I.D. D ₁	O.D. D ₂	I.D. D ₁	O.D. D ₂
15	1/2	—	—	22	47	22	53	—	—	—	—
20	3/4	—	—	28	56	28	66	—	—	—	—
25	1	—	—	34	66	34	72	—	—	—	—
32	1 1/4	—	—	44	75	44	82	—	—	—	—
40	1 1/2	—	—	49	85	49	94	—	—	—	—
50	2	—	—	61	104	61	110	—	—	—	—
65	2 1/2	—	—	77	123	77	129	—	—	—	—
80	3	—	—	90	135	90	148	—	—	—	—
90	3 1/2	—	—	103	161	103	164	—	—	—	—
100	4	—	—	116	173	116	180	—	—	—	—
125	5	—	—	143	196	143	215	—	—	—	—
150	6	—	—	169	221	169	249	—	—	—	—
200	8	—	—	220	277	220	306	—	—	—	—
250	10	—	—	275	338	275	360	—	—	—	—
300	12	—	—	326	408	326	420	—	—	—	—
350	14	—	—	358	449	358	484	—	—	—	—
400	16	—	—	408	512	408	538	—	—	—	—
450	18	—	—	459	547	459	595	—	—	—	—
500	20	—	—	510	604	510	651	—	—	—	—
550	22	—	—	(561)	(657)	(561)	(702)	—	—	—	—
600	24	—	—	612	715	612	772	—	—	—	—
650	26	663	705	663	722	663	768	711	737	724	749
700	28	714	756	714	773	714	822	762	787	775	800
750	30	765	807	765	824	765	883	813	845	826	857
800	32	816	857	816	878	816	937	864	895	876	908
850	34	867	908	867	932	867	991	911	949	927	959
900	36	917	970	917	984	917	1,045	962	1,000	984	1,022
950	38	968 (968)	1,021 (1,021)	968 (968)	1,041 (1,035)	968 (968)	1,096 (1,096)	1,013	1,051	1,035	1,073
1,000	40	1,019 (1,019)	1,072 (1,072)	1,019 (1,019)	1,092 (1,093)	1,019 (1,019)	1,147 (1,147)	1,064	1,102	1,080	1,124
1,050	42	1,070	1,122	1,070	1,143	1,070	1,197	1,118	1,162	1,130	1,181
1,100	44	1,121 (1,121)	1,178 (1,173)	1,121 (1,121)	1,194 (1,201)	1,121 (1,121)	1,248 (1,248)	1,168	1,213	1,191	1,241
1,150	46	1,171 (1,171)	1,229 (1,229)	1,171 (1,171)	1,253 (1,252)	1,171 (1,171)	1,315 (1,314)	1,219	1,264	1,241	1,292
1,200	48	1,222	1,280	1,222	1,303	1,222	1,365	1,270	1,314	1,292	1,343
1,250	50	1,273	1,331	1,273	1,354	1,273	1,416	1,321	1,365	—	—
1,300	52	1,324	1,384	1,324	1,405	1,324	1,467	1,372	1,422	—	—
1,350	54	1,375	1,435	1,375	1,461	1,375	1,527	1,422	1,473	—	—
1,400	56	1,425	1,493	1,425	1,511	1,425	1,591	—	—	—	—
1,450	58	1,476	1,543	1,476	1,577	1,476	1,651	—	—	—	—
1,500	60	1,527	1,594	1,527	1,625	1,527	1,702	1,575	1,626	—	—

*The dimensions in parentheses () are the flange dimensions stipulated in the old version of standard JPI-7S-43-72.

*The values in the bold border **□** are the dimensions for series B.

For JPI pipe flanges

Soft gaskets / ring gaskets (F.R.) Group II

■ **Applicable gaskets**

The main applicable gaskets are jointing sheets, and the gasket thickness is 0.8 mm or 1.5 mm

■ **Applicable standard**

JPI-7S-16-2014 "Dimensions of Non-metallic Gaskets for Pipes," Appendix Tables 2 and 4 Dimensions

■ **Applicable flanges**

JPI-7S-15-99 "Flanges for the Petroleum Industry"

ASME B 16.5 "Pipe Flanges and Flanged Fittings"

ANSI B 16.5 "Steel pipe Flange"

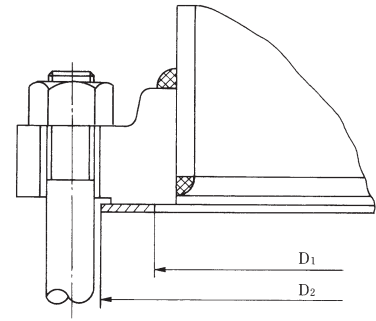

[Dimension Table 4]

Unit [mm]

Nominal flange diameter		Class 150		Class 300	
A	B	I.D. D ₁	O.D. D ₂	I.D. D ₁	O.D. D ₂
15	1/2	25	47	25	53
20	3/4	33	56	33	66
25	1	38	66	38	72
32	1 1/4	48	75	48	82
40	1 1/2	54	85	54	94
50	2	73	104	73	110
65	2 1/2	86	123	86	129
80	3	108	135	108	148
90	3 1/2	121	161	121	164
100	4	132	173	132	180
125	5	160	196	160	215
150	6	190	221	190	249
200	8	238	277	238	306
250	10	287	338	287	360
300	12	344	408	344	420
350	14	376	449	376	484
400	16	427	512	427	538
450	18	490	547	490	595
500	20	535	604	535	651
600	24	643	715	643	772

*For sealing a gas-type fluid, we recommend the Group II dimensions.

For JPI pipe flanges and JPI large bore flange series B

Soft gaskets / full-face gaskets (F.F.)

■ **Applicable gaskets**

Joining sheets, fluoropolymer gaskets, GRASEAL™ gaskets, rubber cut gaskets, cloth reinforced rubber cut gaskets

■ **Applicable standard**

JPI-7S-16-2014 "Dimensions of Non-metallic Gaskets for Pipes,"
Dimensions for full-face seat

■ **Applicable flanges**

JPI-7S-15-85 "Flanges for the Petroleum Industry"
JPI-7S-43-84 "Large Bore flanges for the Petroleum Industry"
ASME B 16.5 "Pipe Flanges and Flanged Fittings"
ASME B 16.47 (series B) "Large Diameter Steel Flanges"

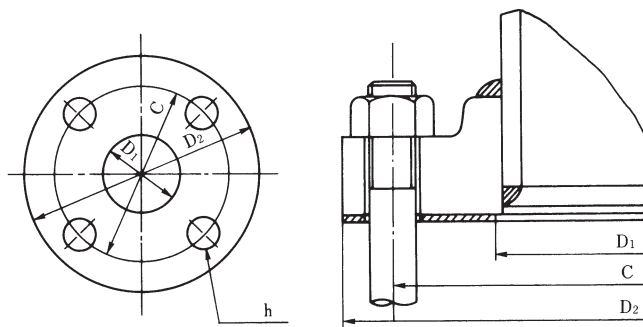

[Dimension Table 5]

Unit [mm]

Nominal flange diameter		I.D. D ₁	Class 75			Class 150			Class 300		
A	B		O.D. D ₂	Pitch circle diameter C	n x h	O.D. D ₂	Pitch circle diameter C	n x h	O.D. D ₂	Pitch circle diameter C	n x h
15	1/2	22	—	—	—	89	60.5	4 x 16	95	66.5	4 x 16
20	3/4	28	—	—	—	99	69.8	4 x 16	117	82.6	4 x 19
25	1	34	—	—	—	108	79.2	4 x 16	124	88.9	4 x 19
32	1 1/4	44	—	—	—	117	88.9	4 x 16	133	98.6	4 x 19
40	1 1/2	49	—	—	—	127	98.6	4 x 16	155	114.3	4 x 22
50	2	61	—	—	—	152	120.6	4 x 19	165	127.0	8 x 19
65	2 1/2	77	—	—	—	178	139.7	4 x 19	190	149.4	8 x 22
80	3	90	—	—	—	190	152.4	4 x 19	210	168.1	8 x 22
90	3 1/2	103	—	—	—	216	177.8	8 x 19	229	184.2	8 x 22
100	4	116	—	—	—	229	190.5	8 x 19	254	200.2	8 x 22
125	5	143	—	—	—	254	215.9	8 x 22	279	235.0	8 x 22
150	6	169	—	—	—	279	241.3	8 x 22	318	269.7	12 x 22
200	8	220	—	—	—	343	298.4	8 x 22	381	330.2	12 x 26
250	10	275	—	—	—	406	362.0	12 x 26	444	387.4	16 x 29
300	12	326	—	—	—	483	431.8	12 x 26	520	450.8	16 x 32
350	14	358	—	—	—	535	476.2	12 x 29	585	514.4	20 x 32
400	16	408	—	—	—	595	539.8	16 x 29	650	571.5	20 x 35
450	18	459	—	—	—	635	577.8	16 x 32	710	628.6	24 x 35
500	20	510	—	—	—	700	635.0	20 x 32	775	685.8	24 x 35
550	22	561	—	—	—	(750)	(692.2)	(20 x 35)	(840)	(743.0)	(24 x 42)
600	24	612	—	—	—	815	749.3	20 x 35	915	812.8	24 x 42
650	26	663	760	723.9	36 x 19	785	744.5	36 x 22	865	803.1	32 x 35
700	28	714	815	774.7	40 x 19	835	795.3	40 x 22	920	857.2	36 x 35
750	30	765	865	825.5	44 x 19	885	846.1	44 x 22	990	920.8	36 x 39
800	32	816	915	876.3	48 x 19	940	900.2	48 x 22	1,055	977.9	32 x 42
850	34	867	965	927.1	52 x 19	1,005	957.3	40 x 26	1,110	1,031.7	36 x 42
900	36	917	1,035	992.1	40 x 22	1,055	1,009.6	44 x 26	1,170	1,089.2	32 x 45
950	38	968	1,085	1,042.9	40 x 22	1,125	1,069.8	40 x 29	1,220	1,140.0	36 x 45
1,000	40	1,019	1,135	1,093.7	44 x 22	1,175	1,120.6	44 x 29	1,275	1,190.8	40 x 45
1,050	42	1,070	1,185	1,144.5	48 x 22	1,225	1,171.4	48 x 29	1,335	1,244.6	36 x 48
1,100	44	1,121	1,250	1,203.4	36 x 26	1,275	1,222.2	52 x 29	1,385	1,295.4	40 x 48
1,150	46	1,171	1,300	1,254.3	40 x 26	1,340	1,284.2	40 x 32	1,460	1,365.2	36 x 51
1,200	48	1,222	1,355	1,305.1	44 x 26	1,390	1,335.0	44 x 32	1,510	1,416.0	40 x 51
1,250	50	1,273	1,405	1,355.9	44 x 26	1,445	1,385.8	48 x 32	1,560	1,466.8	44 x 51
1,300	52	1,324	1,455	1,409.7	48 x 26	1,495	1,436.6	52 x 32	1,615	1,517.6	48 x 51
1,350	54	1,375	1,510	1,460.5	48 x 26	1,550	1,492.2	56 x 32	1,675	1,577.8	48 x 51
1,400	56	1,425	1,575	1,521.0	40 x 29	1,600	1,543.0	60 x 32	1,765	1,651.0	36 x 60
1,450	58	1,476	1,625	1,571.8	44 x 29	1,675	1,611.4	48 x 35	1,825	1,713.0	40 x 60
1,500	60	1,527	1,675	1,622.6	44 x 29	1,725	1,662.2	52 x 35	1,880	1,763.8	40 x 60

*When using a joining sheet as a full-face type, it is difficult to seal a gas-type fluid.

*The values inside the bold border □ indicate the dimensions for series B.

Soft gaskets

■ **Applicable gaskets**

Joining sheets, fluoropolymer gaskets, GRASEAL™ gaskets

■ **Applicable standard**

JIS B 2404-2006 "Dimensions of Gaskets for Use with Pipe Flanges," Appendix Table 5 Dimensions

■ **Applicable flanges**

JIS B 2220-2004 "Steel Pipe Flanges" (Latest: 2012)
(Old) JIS B 2238-1996 "General Rules for Steel Pipe Flanges"

(Old) JIS B 2239-1996 "General Rules for Cast Iron Pipe Flanges"

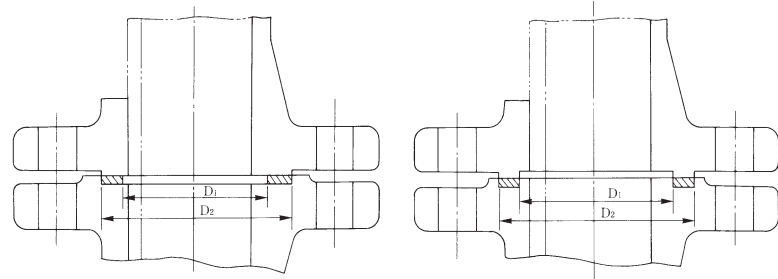

Male and female type

Tongue & groove type

[Dimension Table 6]

Unit [mm]

Nominal flange diameter	M&F type		T&G type	
	Gasket I.D. D ₁	Gasket O.D. D ₂	Gasket I.D. D ₁	Gasket O.D. D ₂
10A	18	38	28	38
15	22	42	32	42
20	28	50	38	50
25	35	60	45	60
32	43	70	55	70
40	49	75	60	75
50	61	90	70	90
65	77	110	90	110
80	90	120	100	120
90	102	130	110	130
100	115	145	125	145
125	141	175	150	175
150	167	215	190	215
200	218	260	230	260
250	270	325	295	325
300	321	375	340	375
350	359	415	380	415
400	410	475	440	475
450	460	523	483	523
500	513	575	535	575
550	564	625	585	625
600	615	675	635	675
650	667	727	682	727
700	718	777	732	777
750	770	832	787	832
800	820	882	837	882
850	872	934	889	934
900	923	987	937	987
1,000	1,025	1,092	1,042	1,092
1,100	1,130	1,192	1,142	1,192
1,200	1,230	1,292	1,237	1,292
1,300	1,335	1,392	1,337	1,392
1,350	1,385	1,442	1,387	1,442
1,400	1,435	1,492	1,437	1,492
1,500	1,540	1,592	1,537	1,592

Soft gaskets

■ Applicable gasket

The main applicable gaskets are jointing sheets.

■ Applicable standard

JPI-7S-16-2014 "Dimensions of Non-metallic Gaskets for Pipes"

■ Applicable flanges

JPI-7S-15-99 "Flanges for the Petroleum Industry"

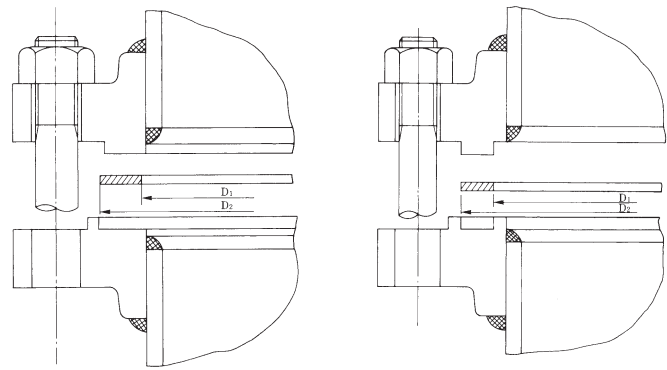

Large male & female seat type

Large tongue & groove seat type

[Dimension Table 7]

Unit [mm]

Nominal flange diameter		Large male & female seats				Large tongue & groove seat	
		Group I		Group II		Group II	
A	B	I.D. D ₁	O.D. D ₂	I.D. D ₁	O.D. D ₂	I.D. D ₁	O.D. D ₂
15	1/2	22	35	25	35	25	35
20	3/4	28	43	33	43	33	43
25	1	34	51	38	51	38	51
32	1 1/4	44	64	48	64	48	64
40	1 1/2	49	73	54	73	54	73
50	2	61	92	73	92	73	92
65	2 1/2	77	105	86	105	86	105
80	3	90	127	108	127	108	127
90	3 1/2	103	140	121	140	121	140
100	4	116	157	132	157	132	157
125	5	143	186	160	186	160	186
150	6	169	216	190	216	190	216
200	8	220	268	238	268	238	268
250	10	275	323	287	323	287	323
300	12	326	380	344	380	344	380
350	14	358	412	376	412	376	412
400	16	408	469	427	469	427	469
450	18	459	532	490	532	490	532
500	20	510	583	535	583	535	583
600	24	612	690	643	690	643	690

Soft gaskets / ring gaskets (F.R.)

■ Applicable gaskets

Joining sheets, fluoropolymer gaskets, GRASEAL™ gaskets, rubber cut gaskets, cloth reinforced rubber cut gaskets

■ Applicable standard

ASME B 16.21-2005 "Non-metallic Flat Gaskets for Pipe Flanges"

■ Applicable flanges

ANSI B 16.1 "Cast Iron Pipe Flanges and Flanged Fittings"

ANSI B 16.5 "Pipe Flanges and Flanged Fittings"

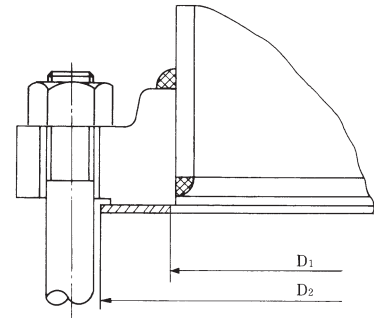

[Dimension Table 8]

Unit [mm]

Nominal flange diameter	Gasket I.D. D ₁	For ANSI B 16.1 Cast Iron flanges			For ANSI 16.5 Pipe flanges	
		Gasket O.D. D ₂			Gasket O.D. D ₂	
		Class 25	Class 125	Class 250	Class 150	Class 300
1/2B	21	—	—	—	48	54
3/4	27	—	—	—	57	67
1	33	—	67	73	67	73
1 1/4	42	—	76	83	76	83
1 1/2	49 (48)	—	86	95	86	95
2	60	—	105	111	105	111
2 1/2	73	—	124	130	124	130
3	89	—	137	149	137	149
3 1/2	102	—	162	165	162	165
4	114	175	175	181	175	181
5	141	200	197	216	197	216
6	168	225	222	251	222	251
8	219	283	279	308	279	308
10	273	346	352	362	340	362
12	324	416	410	422	410	422
14	356	457	451	486	451	486
16	406	521	514	540	514	540
18	457	559	549	597	549	597
20	508	616	606	654	606	654
24	610	730	718	775	718	775
30	762	892	883	953	—	—
36	914	1,064	1,048	1,118	—	—
42	1,067	1,232	1,219	1,289	—	—
48	1,219	1,397	1,384	1,492	—	—
54	1,372	1,568	—	—	—	—
60	1,524	1,730	—	—	—	—
72	1,829	2,067	—	—	—	—
84	2,134	2,394	—	—	—	—
96	2,438	2,724	—	—	—	—

*The use of joining sheets is not recommended for Class 25.

*The value in parentheses () is the dimension for ANSI B 16.5 Pipe flanges.

Soft gaskets / full-face gaskets (F.F.)

■ **Applicable gaskets**

Joining sheets, fluoropolymer gaskets, GRASEAL™ gaskets, rubber cut gaskets, cloth reinforced rubber cut gaskets

■ **Applicable standard**

ASME B 16.21-2011 "Non-metallic Flat Gaskets for Pipe Flanges"

■ **Applicable flanges**

ANSI B 16.1 "Cast Iron Pipe Flanges and Flanged Fittings"
ANSI B 16.5 "Pipe Flanges and Flanged Fittings"

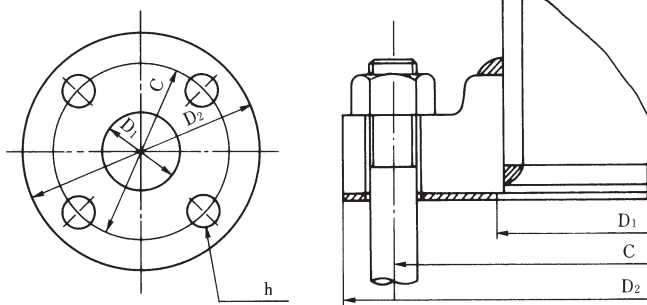

[Dimension Table 9]

Unit [mm]

Nominal flange diameter	Gasket I.D. D ₁	For ANSI B 16.1 Cast Iron flanges						For ANSI 16.5 Steel flanges		
		Class 25			Class 125			Class 150		
		O.D. D ₂	Pitch circle diameter C	n x h	O.D. D ₂	Pitch circle diameter C	n x h	O.D. D ₂	Pitch circle diameter C	n x h
1/2B	21	—	—	—	—	—	—	89	60.3	4 x 15.9
3/4	27	—	—	—	—	—	—	98	69.9	4 x 15.9
1	33	—	—	—	108	79.4	4 x 15.9	108	79.4	4 x 15.9
1 1/4	42	—	—	—	117	88.9	4 x 15.9	117	88.9	4 x 15.9
1 1/2	49	—	—	—	127	98.4	4 x 15.9	127	98.4	4 x 15.9
2	60	—	—	—	152	120.7	4 x 19.1	152	120.7	4 x 19.1
2 1/2	73	—	—	—	178	139.7	4 x 19.1	178	139.7	4 x 19.1
3	89	—	—	—	191	152.4	4 x 19.1	191	152.4	4 x 19.1
3 1/2	102	—	—	—	216	177.8	8 x 19.1	216	177.8	8 x 19.1
4	114	229	190.5	8 x 19.1	229	190.5	8 x 19.1	229	190.5	8 x 19.1
5	141	254	215.9	8 x 19.1	254	215.9	8 x 22.2	254	215.9	8 x 22.2
6	168	279	241.3	8 x 19.1	279	241.3	8 x 22.2	279	241.3	8 x 22.2
8	219	343	298.5	8 x 19.1	343	298.5	8 x 22.2	343	298.5	8 x 22.2
10	273	406	362.0	12 x 19.1	406	362.0	12 x 25.4	406	362.0	12 x 25.4
12	324	483	431.8	12 x 19.1	483	431.8	12 x 25.4	483	431.8	12 x 25.4
14	356	533	476.3	12 x 22.2	533	476.2	12 x 28.6	533	476.3	12 x 28.6
16	406	597	539.8	16 x 22.2	597	539.8	16 x 28.6	597	539.8	16 x 28.6
18	457	635	577.9	16 x 22.2	635	577.9	16 x 31.8	635	577.9	16 x 31.8
20	508	699	635.0	20 x 22.2	699	635.0	20 x 31.8	699	635.0	20 x 31.8
24	610	813	749.3	20 x 22.2	813	749.3	20 x 34.9	813	749.3	20 x 34.9
30	762	984	914.4	28 x 25.4	984	914.4	28 x 34.9	—	—	—
36	914	1,168	1,085.9	32 x 25.4	1,168	1,085.9	32 x 41.3	—	—	—
42	1,067	1,346	1,257.3	36 x 28.6	1,346	1,257.3	36 x 41.3	—	—	—
48	1,219	1,511	1,422.4	44 x 28.6	1,511	1,422.4	44 x 41.3	—	—	—
54	1,372	1,683	1,593.9	44 x 28.6	—	—	—	—	—	—
60	1,524	1,854	1,759.0	52 x 31.8	—	—	—	—	—	—
72	1,829	2,197	2,095.5	60 x 31.8	—	—	—	—	—	—
84	2,134	2,534	2,425.7	64 x 34.9	—	—	—	—	—	—
96	2,438	2,877	2,755.9	68 x 34.9	—	—	—	—	—	—

*The use of joining sheets is not recommended for Class 25 flanges.

(F.R.)

■ Applicable gaskets

Jointing sheets, fluoropolymer gaskets, GRASEAL™ gaskets, rubber cut gaskets, cloth reinforced rubber cut gaskets

■ Applicable standard

ASME B 16.21-2005 "Non-metallic Flat Gaskets for Pipe Flanges"

■ Applicable flanges

ASME B 16.47 (Series A) "Large Diameter Steel Flanges"
(MSS-SP-44-1982 "Steel Pipe line Flanges")

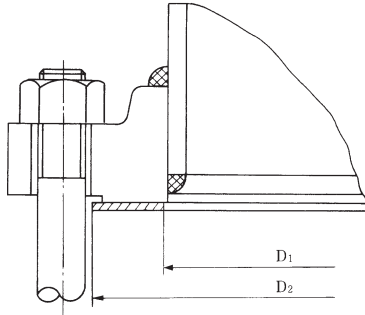

[Dimension table 10]

Unit [mm]

Nominal flange diameter	Gasket I.D. D ₁	Gasket O.D. D ₂	
		Class 150	Class 300
22 ⁽¹⁾	559	660	705
26	660	775	835
28	711	832	899
30	762	883	953
32	813	940	1,006
34	864	991	1,057
36	914	1,048	1,118
38	965	1,111	1,054
40	1,016	1,162	1,114
42	1,067	1,219	1,165
44	1,118	1,276	1,219
46	1,168	1,327	1,273
48	1,219	1,384	1,324
50	1,270	1,435	1,378
52	1,321	1,492	1,429
54	1,372	1,549	1,492
56	1,422	1,607	1,543
58	1,473	1,664	1,594
60	1,524	1,715	1,645

Note: (1) Because this value is not stipulated in ASME B16.47, it is only used for reference.

Union Table

■ Applicable gaskets

Mainly jointing sheets

■ Reference standard⁽²⁾

JIS B 2301 "Screwed type malleable cast iron pipe fittings"

Note:(2) This dimension table has been prepared by Nichias based on the above standard.

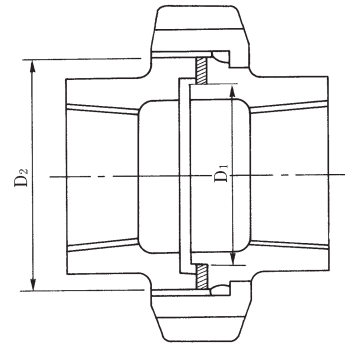

[Dimension Table 11]

Unit [mm]

Nominal union diameter	I.D. D ₁	O.D. D ₂
1/8B	13	18
1/4	17	23
3/8	21	28
1/2	25	32
3/4	31	39
1	39	48
1 1/4	47	57
1 1/2	54	64
2	66	78
2 1/2	82	96
3	96	111
3 1/2	109	126
4	122	141
5	151	170
6	178	200

*The recommended gasket thickness is 2.0mm or 1.5mm.

For JIS pipe flanges

VORTEX™ gaskets with outer ring

■ **Applicable gaskets**

GRASEAL™ VORTEX™, NA VORTEX™, NAFLON™ VORTEX™, VORTEX™ gaskets -GS, -GM and -GH

■ **Applicable standard**

JIS B 2404-2006 "Dimensions of Gaskets for Use with Pipe Flanges," Appendix Tables 6, 7, Appendix 1 Appendix Tables 2, 4 Dimensions

■ **Applicable flanges**

JIS B 2220-2012 "Steel Pipe Flanges"

(Old) JIS B 2238-1996 "General Rules for Steel Pipe Flanges"

(Old) JIS B 2239-1996 "General Rules for Cast Iron Pipe Flanges"

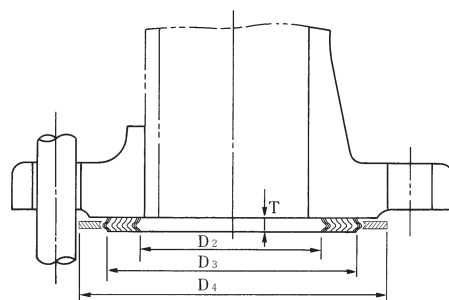

*The O.D. dimension of the body of a gasket with an outer ring is expressed as the dimension of the gasket shoulder excluding spring layers.

[Dimension Table 12]

Unit [mm]

Nominal flange diameter	Nominal pressure 10K			16, 20K			30K			40K			63K			Thickness T
	I.D. D ₂	O.D. D ₃	Outer ring outer diameter D ₄	I.D. D ₂	O.D. D ₃	Outer ring outer diameter D ₄	I.D. D ₂	O.D. D ₃	Outer ring outer diameter D ₄	I.D. D ₂	O.D. D ₃	Outer ring outer diameter D ₄	I.D. D ₂	O.D. D ₃	Outer ring outer diameter D ₄	
10A	24	37	52	24	37	52	24	37	59	21	34	59	21	34	64	4.5
15	28	41	57	28	41	57	28	41	64	24	37	64	24	37	69	
20	34	47	62	34	47	62	34	47	69	29	42	69	29	42	75	
25	40	53	74	40	53	74	40	53	79	35	48	79	35	48	80	
32	51	67	84	51	67	84	51	67	89	44	60	89	44	60	90	
40	57	73	89	57	73	89	57	73	100	51	67	100	51	67	107	
50	69	89	104	69	89	104	69	89	114	63	79	114	63	79	125	
65	87	107	124	87	107	124	78	98	140	78	98	140	78	98	152	
80	98	118	134	99	119	140	90	110	150	90	110	150	90	110	162	
90	110	130	144	114	139	150	102	127	162	102	127	162	102	127	179	
100	123	143	159	127	152	165	116	141	172	116	141	182	116	141	194	
125	148	173	190	152	177	202	140	165	207	140	165	224	140	165	235	
150	174	199	220	182	214	237	165	197	249	165	197	265	165	197	275	
175	201	226	245	—	—	—	—	—	—	—	—	—	—	—	—	
200	227	252	270	233	265	282	218	250	294	218	250	315	218	250	328	
225	252	277	290	—	—	—	—	—	—	—	—	—	—	—	—	
250	278	310	332	288	328	354	271	311	360	271	311	378	271	311	394	
300	329	361	377	339	379	404	320	360	418	320	360	434	320	360	446	
350	366	406	422	376	416	450	356	396	463	356	396	479	356	396	488	
400	417	457	484	432	482	508	403	453	524	403	453	531	403	453	545	
450	468	518	539	483	533	573	—	—	—	—	—	—	—	—	—	
500	518	568	594	533	583	628	—	—	—	—	—	—	—	—	—	
550	569	619	650	584	634	684	—	—	—	—	—	—	—	—	—	
600	620	670	700	635	685	734	—	—	—	—	—	—	—	—	—	

*The dimensions in the double border □ cannot be used on small flat seats.

*The dimensions in the bold border ■ apply to large flat seats and small flat seats. (Note, however, that these dimensions apply only to butt-welded flanges and type C slip-on welded flanges stipulated in JIS B 2220.)

*■ : For a 30K type A slip-on welded flange and a type B slip-on welded flange, use the dimensions on Page 80.

*It is recommended that VORTEX™ gaskets with inner and outer rings be used on flanges that are intended for a nominal pressure of 63K.

*It is recommended that GRASEAL™ VORTEX™ gaskets and NAFLON™ VORTEX™ gaskets fitted with inner and outer rings.

*It is not recommended that VORTEX™ gaskets used on flanges intended for nominal pressures 2K and 5K.

*It is recommended that high-strength alloy steel bolts of SNB-7 or higher to be used.

VORTEX™ gaskets with inner and outer rings

■ **Applicable gaskets**

GRASEAL™ VORTEX™, NA VORTEX™, NAFLON™ VORTEX™, VORTEX™ gaskets -GS, -GM and -GH

■ **Applicable standard** ⁽¹⁾

JIS B 2404-2006 "Dimensions of Gaskets for Use with Pipe Flanges," Appendix Tables 6, 8, Appendix 1 Appendix Tables 3, 5 Dimensions

■ **Applicable flanges**

JIS B 2220-2012 "Steel Pipe Flanges"

(Old) JIS B 2238-1996 "General Rules for Steel Pipe Flanges"

(Old) JIS B 2239-1996 "General Rules for Cast Iron Pipe Flanges"

Note: (1) The I.D. of the inner ring of a gasket for a nominal pressure of 10K has been prepared by Nichias.

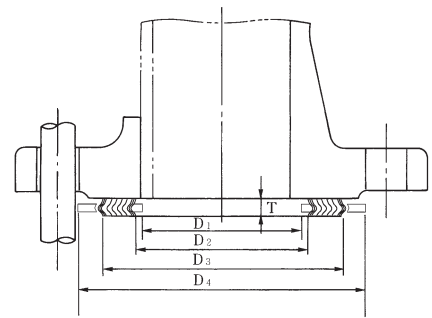

*The O.D. dimension of the body of a gasket with inner and outer rings is expressed as the dimension of the gasket shoulder excluding spring layers.

[Dimension Table 13-1]

Unit [mm]

Nominal flange diameter	Nominal pressure 10K				16, 20K				30K				40K				63K				Thickness T
	Inner ring I.D. D ₁	I.D. D ₂	O.D. D ₃	Outer ring O.D. D ₄	Inner ring I.D. D ₁	I.D. D ₂	O.D. D ₃	Outer ring O.D. D ₄	Inner ring I.D. D ₁	I.D. D ₂	O.D. D ₃	Outer ring O.D. D ₄	Inner ring I.D. D ₁	I.D. D ₂	O.D. D ₃	Outer ring O.D. D ₄	Inner ring I.D. D ₁	I.D. D ₂	O.D. D ₃	Outer ring O.D. D ₄	
10A	18	24	37	52	18	24	37	52	18	24	37	59	15	21	34	59	15	21	34	64	4.5
15	22	28	41	57	22	28	41	57	22	28	41	64	18	24	37	64	18	24	37	69	
20	28	34	47	62	28	34	47	62	28	34	47	69	23	29	42	69	23	29	42	75	
25	34	40	53	74	34	40	53	74	34	40	53	79	29	35	48	79	29	35	48	80	
32	43	51	67	84	43	51	67	84	43	51	67	89	38	44	60	89	38	44	60	90	
40	49	57	73	89	49	57	73	89	49	57	73	100	43	51	67	100	43	51	67	107	
50	61	69	89	104	61	69	89	104	61	69	89	114	55	63	79	114	55	63	79	125	
65	77	87	107	124	77	87	107	124	68	78	98	140	68	78	98	140	68	78	98	152	
80	88	98	118	134	89	99	119	140	80	90	110	150	80	90	110	150	80	90	110	162	
90	98	110	130	144	102	114	139	150	92	102	127	162	92	102	127	162	92	102	127	179	
100	111	123	143	159	115	127	152	165	104	116	141	172	104	116	141	182	104	116	141	194	
125	136	148	173	190	140	152	177	202	128	140	165	207	128	140	165	224	128	140	165	235	
150	158	174	199	220	166	182	214	237	153	165	197	249	153	165	197	265	153	165	197	275	
200	211	227	252	270	217	233	265	282	202	218	250	294	202	218	250	315	202	218	250	328	
250	258	278	310	332	268	288	328	354	251	271	311	360	251	271	311	378	251	271	311	394	
300	309	329	361	377	319	339	379	404	300	320	360	418	300	320	360	434	300	320	360	446	
350	346	366	406	422	356	376	416	450	336	356	396	463	336	356	396	479	336	356	396	488	
400	392	417	457	484	407	432	482	508	383	403	453	524	383	403	453	531	383	403	453	545	
450	443	468	518	539	458	483	533	573	—	—	—	—	—	—	—	—	—	—	—	—	
500	493	518	568	594	508	533	583	628	—	—	—	—	—	—	—	—	—	—	—	—	
550	544	569	619	650	559	584	634	684	—	—	—	—	—	—	—	—	—	—	—	—	
600	595	620	670	700	610	635	685	734	—	—	—	—	—	—	—	—	—	—	—	—	

*The dimensions in the double border cannot be used on small flat seats.

*The dimensions in the bold border apply to large flat seats and small flat seats. (Note, however, that these dimensions apply only to butt-welded flanges and type C slip-on welded flanges stipulated in JIS B 2220.)

*For a 30K type A slip-on welded flange and a type B slip-on welded flange, use the dimensions on Page 80.

*It is recommended that VORTEX™ gaskets with inner and outer rings be used on flanges for a nominal pressure of 63K.

*It is recommended that high-strength alloy steel bolts of SNB-7 or higher to be used.

For JIS pipe large-bore flanges

VORTEX™ gaskets with inner and outer rings

■ Applicable gaskets

GRASEAL™ VORTEX™, NA VORTEX™, NAFLON™ VORTEX™, VORTEX™ gaskets -GS, -GM and -GH

■ Applicable flanges

JIS B 2220-2012 "Steel Pipe Flanges"

(Old) JIS B 2238-1996 "General Rules for Steel Pipe Flanges"

(Old) JIS B 2239-1996 "General Rules for Cast Iron Pipe Flanges"

*This dimension table has been prepared by Nichias based on the above standards.

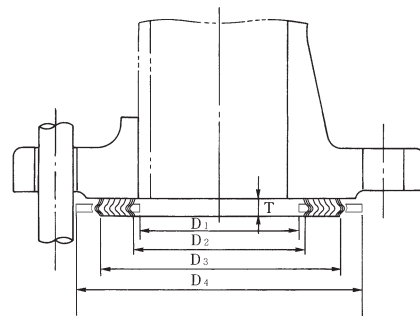

*The O.D. dimension of the body of a gasket with inner and outer rings is expressed as the dimension of a gasket shoulder excluding spring layers.

[Dimension Table 14]

Unit [mm]

Nominal flange diameter	Nominal pressure 10K				16K				20K			
	Inner ring I.D. D ₁	I.D. D ₂	O.D. D ₃	Outer ring O.D. D ₄	Inner ring I.D. D ₁	I.D. D ₂	O.D. D ₃	Outer ring O.D. D ₄	Inner ring I.D. D ₁	I.D. D ₂	O.D. D ₃	Outer ring O.D. D ₄
650A	650	675	725	750	674	699	749	784	695	720	770	805
700	701	726	776	810	716	741	791	836	740	765	815	855
750	752	777	827	870	777	802	852	896	799	824	874	918
800	803	828	878	920	831	856	906	945	865	881	931	978
850	854	879	929	970	880	905	955	995	919	944	994	1,038
900	904	929	979	1,020	934	959	1,009	1,045	971	996	1,046	1,088
1,000	1,006	1,036	1,086	1,124	1,030	1,060	1,110	1,158	—	—	—	—
1,100	1,108	1,138	1,188	1,234	1,132	1,162	1,212	1,258	—	—	—	—
1,200	1,209	1,239	1,289	1,344	1,240	1,270	1,320	1,368	—	—	—	—
1,300	—	—	—	—	1,341	1,371	1,421	1,474	—	—	—	—
1,350	1,362	1,392	1,442	1,498	1,403	1,433	1,483	1,534	—	—	—	—
1,400	—	—	—	—	1,453	1,483	1,533	1,584	—	—	—	—
1,500	1,514	1,544	1,594	1,658	1,559	1,589	1,639	1,694	—	—	—	—

*It is recommended that high-strength alloy steel bolts of SNB-7 or higher to be used.

For type A slip-on welded flanges (socket-welded type)

VORTEX™ gaskets with inner and outer rings

[Dimension Table 13-2] Unit [mm]

Nominal flange diameter	30K			
	Inner ring I.D. D ₁	I.D. D ₂	O.D. D ₃	Outer ring O.D. D ₄
10A	21.0	29.0	42.0	59.0
15	25.0	32.0	45.0	64.0
20	30.5	37.0	50.0	69.0
25	37.5	47.0	60.0	79.0
32	46.0	54.0	70.0	89.0
40	52.0	64.0	80.0	100.0
50	64.0	75.0	95.0	114.0
65	80.0	100.0	120.0	140.0
80	93.0	110.0	130.0	150.0
90	105.5	120.0	140.0	163.0
100	118.5	130.0	150.0	173.0
125	146.0	160.0	185.0	208.0
150	171.5	190.0	220.0	251.0
200	223.0	235.0	265.0	296.0
250	274.0	290.0	330.0	360.0
300	326.0	350.0	390.0	420.0
350	363.0	395.0	435.0	465.0
400	414.0	445.0	495.0	524.0

For type B slip-on welded flanges (socket-welded type)

VORTEX™ gaskets with inner and outer rings

[Dimension Table 13-3] Unit [mm]

Nominal flange diameter	20K				30K			
	Inner ring I.D. D ₁	I.D. D ₂	O.D. D ₃	Outer ring O.D. D ₄	Inner ring I.D. D ₁	I.D. D ₂	O.D. D ₃	Outer ring O.D. D ₄
10	23	29	39	52	30	36	46	59
15	27	33	43	57	36	42	52	64
20	33	39	49	62	40	46	56	69
25	38	46	59	74	46	54	67	79
32	47	55	68	84	54	62	75	89
40	53	61	74	89	60	68	81	100
50	64	74	90	104	70	80	96	114

Slip-on welded flange (socket-welded flange)

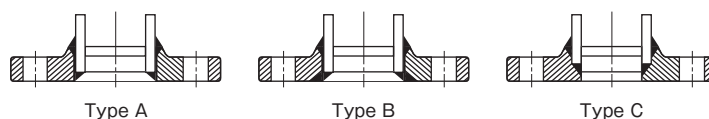

In the case of a slip-on welded type flange, the pipe is inserted into the flange, and then welded to the top part and the inner I.D. of the flange. JIS 20K and 30K flanges consist of types A, B and C in the figure above. (The figure shows hub flanges.)

Basic type VORTEX™ gaskets with inner ring

■ **Applicable gaskets**
 GRASEAL™ VORTEX™, NA VORTEX™, NAFLON™ VORTEX™,
 VORTEX™ gaskets -GS, -GM, -GH

■ **Applicable standard**
 JIS B 2404-2006 "Dimensions of Gaskets for Use with Pipe Flanges," Table 11 to Table 13 Dimensions

■ **Applicable flanges**
 JIS B 2220-2012 "Steel Pipe Flanges"
 (Old) JIS B 2238-1996 "General Rules for Steel Pipe Flanges"

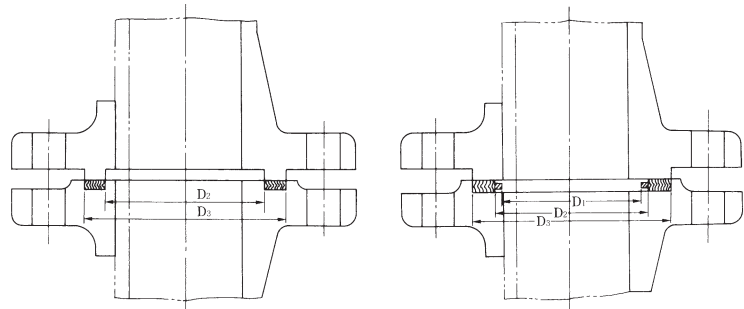

Tongue & groove type

Male & female type

[Dimension Table 5]

Unit [mm]

Nominal flange diameter	For JIS standard flanges						
	Tongue & groove type flange		Male & female type flange				
	Basic type		Basic type		With inner ring		
	I.D. D ₂	O.D. D ₃	I.D. D ₂	O.D. D ₃	Inner ring I.D. D ₁	I.D. D ₂	O.D. D ₃
10 A	28	38	25	38	19	25	38
15	32	42	29	42	23	29	42
20	38	50	37	50	31	37	50
25	45	60	44	60	38	44	60
32	55	70	54	70	46	54	70
40	60	75	59	75	51	59	75
50	70	90	70	90	62	70	90
65	90	110	90	110	80	90	110
80	100	120	100	120	90	100	120
90	110	130	110	130	100	110	130
100	125	145	125	145	113	125	145
125	150	175	150	175	138	150	175
150	190	215	187	215	171	187	215
200	230	259	231	259	215	231	259
250	296	324	288	324	268	288	324
300	341	374	338	374	318	338	374
350	381	414	376	414	356	376	414
400	441	474	434	474	409	434	474
450	484	522	482	522	457	482	522
500	536	574	534	574	509	534	574
550	586	624	584	624	559	584	624
600	636	674	634	674	609	634	674

*When you use a VORTEX™ gasket with inner ring on a slip-on welded type flange, the inner ring I.D. protrudes from the I.D. of the flange, so please use caution.
 *It is recommended that high-strength alloy steel bolts of at least SNB-7 to be used.

For JPI pipe flanges

VORTEX™ gaskets (15A - 600A) with (inner) outer ring

■ Applicable gaskets

TOMBO™ No.1834 (R) -GR, TOMBO™ No.1834 (R) -NA,
TOMBO™ No.9090 -(I) OR

■ Applicable standard

JPI-7S-41-2005 "VORTEX™ Gaskets for Pipes" Appendix Tables 2, 3 Reference Appendix
Table 1 Dimensions

The values in parentheses () are the values in (Old) JPI-7S-41-1998.

■ Applicable flanges

JPI-7S-15 "Forged Steel Flanges for the Petroleum Industry"
JPI-7S-43 "Large Bore Flanges" Series B
ANSI B 16.5-1981 "Steel Pipe Flanges"
ASME B 16.47-1996 "Large-Diameter Steel Flanges, series B"
API-Std 605-1980 "Large-Diameter Carbon Steel Flanges"

[Dimension Table 16]

Unit [mm]

Nominal flange diameter		Class 150				Class 300				Class 400			
A	B	Inner ring I.D. D ₁	Main body I.D. D ₂	Main body O.D. D ₃	Outer ring O.D. D ₄	Inner ring I.D. D ₁	Main body I.D. D ₂	Main body O.D. D ₃	Outer ring O.D. D ₄	Inner ring I.D. D ₁	Main body I.D. D ₂	Main body O.D. D ₃	Outer ring O.D. D ₄
15	1/2	14.2	19.0	31.8	47.8	14.2	19.0	31.8	54.1	14.2	19.0	31.8	54.1
20	3/4	20.6	25.4	39.6	57.2	20.6	25.4	39.6	66.8	20.6	25.4	39.6	66.8
25	1	26.9	31.8	47.8	66.8	26.9	31.8	47.8	73.2	26.9	31.8	47.8	73.2
32	1 1/4	38.1	47.8	60.5	76.2	38.1	47.8	60.5	82.6	38.1	47.8	60.5	82.6
40	1 1/2	44.4	54.1	69.8	85.9	44.4	54.1	69.8	95.2	44.4	54.1	69.8	95.2
50	2	55.6	69.8	85.9	104.9	55.6	69.8	85.9	111.3	55.6	69.8	85.9	111.3
65	2 1/2	66.5	82.6	98.6	124.0	66.5	82.6	98.6	130.3	66.5	82.6	98.6	130.3
80	3	81.0	101.6	120.6	136.7	81.0	101.6	120.6	149.4	81.0	101.6	120.6	149.4
90	3 1/2	93.7	114.3	133.3	161.9	93.7	114.3	133.3	165.1	93.7	114.3	133.3	161.9
100	4	106.4	127.0	149.4	174.8	106.4	127.0	149.4	181.1	102.6 (106.4)	120.6	149.4	177.8
125	5	131.8	155.7	177.8	196.8	131.8	155.7	177.8	215.9	128.3 (131.8)	147.6	177.8	212.9
150	6	157.2	182.6	209.6	222.2	157.2	182.6	209.6	251.0	154.9 (157.2)	174.8	209.6	247.6
200	8	215.9	233.4	263.7	279.4	215.9	233.4	263.7	308.1	205.7 (209.6)	225.6	263.7	304.8
250	10	268.2	287.3	317.5	339.9	268.2	287.3	317.5	362.0	255.3 (260.4)	274.6	317.5	358.9
300	12	317.5	339.9	374.6	409.7	317.5	339.9	374.6	422.4	307.3 (317.5)	327.2	374.6	419.1
350	14	349.2	371.6	406.4	450.8	349.2	371.6	406.4	485.9	342.9 (349.2)	362.0	406.4	482.6
400	16	400.0	422.4	463.6	514.4	400.0	422.4	463.6	539.8	389.9 (400.0)	412.8	463.6	536.7
450	18	449.3	474.7	527.0	549.4	449.3	474.7	527.0	596.9	438.1 (449.3)	469.9	527.0	593.9
500	20	500.1	525.5	577.8	606.6	500.1	525.5	577.8	654.0	488.9 (500.1)	520.7	577.8	647.7
550	22	552.4	577.8	635.0	660.4	552.4	577.8	635.0	704.8	552.4	577.8	635.0	701.8
600	24	603.2	628.6	685.8	717.6	603.2	628.6	685.8	774.7	590.5 (603.2)	628.6	685.8	768.4

*When using this type of gasket on a flange that has a nominal pressure of at least Class 900, use a butt-welded flange.

*Use high-strength alloy steel bolts of SNB-7 or higher.

*When using this type of gasket on a slip-on welded flange, the inner ring I.D. may sometimes protrude from the I.D. of the flange, so please use caution. The use of a butt-welded flange is recommended.

*The values inside the bold border **□** cannot be used for a slip-on welded flange. Use them for a butt-welded flange or a socket-welded flange. (For the dimensions in the case where a slip-on welded flange is used, refer to Dimension Table 17 at bottom right.)

***□**: When using this type of gasket on a flange that has a nominal pressure of at least Class 900, it is recommended that you use a gasket with inner and outer rings.

For slip-on welded flanges (socket-welded flange)

Dimensions (inside the bold border of Table 16) when this type of gasket is to be used for a slip-on welded flange

■ Flange classification

Slip-on welded flange (socket-welded type)

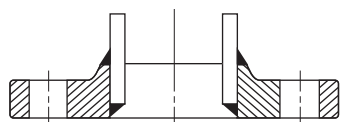

A type of flange into which the pipe is inserted into the flange and welded to the top part and the inner I.D. of the flange.

Socket-welded flange

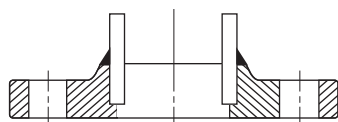

In the case of this flange, the pipe is placed on the step at I.D. of the flange and welded only to the top part of the flange. Because the I.D. side is not welded, there is a risk of the flange face becoming damaged.

Butt-welded flange

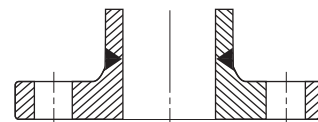

A type of flange to which the pipe is directly butt-welded.

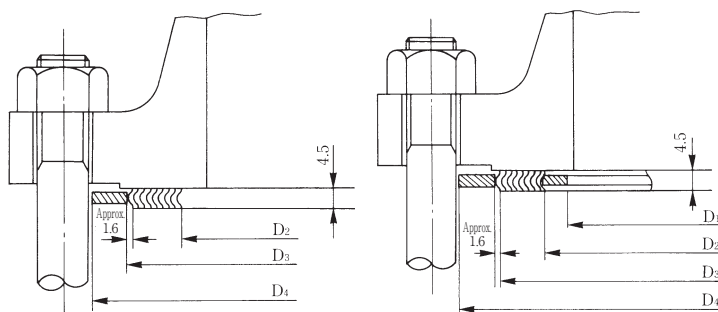

*The O.D. of the main body is expressed as the dimension of the convex part excluding spring layers.

Unit [mm]

Nominal flange diameter		Class 600				Class 900				Class 1500				Class 2500			
A	B	Inner ring I.D. D ₁	Main body I.D. D ₂	Main body O.D. D ₃	Outer ring O.D. D ₄	Inner ring I.D. D ₁	Main body I.D. D ₂	Main body O.D. D ₃	Outer ring O.D. D ₄	Inner ring I.D. D ₁	Main body I.D. D ₂	Main body O.D. D ₃	Outer ring O.D. D ₄	Inner ring I.D. D ₁	Main body I.D. D ₂	Main body O.D. D ₃	Outer ring O.D. D ₄
15	1/2	14.2	19.0	31.8	54.1	14.2	19.0	31.8	63.5	14.2	19.0	31.8	63.5	14.2	19.0	31.8	69.8
20	3/4	20.6	25.4	39.6	66.8	20.6	25.4	39.6	69.8	20.6	25.4	39.6	69.8	20.6	25.4	39.6	76.2
25	1	26.9	31.8	47.8	73.2	26.9	31.8	47.8	79.5	26.9	31.8	47.8	79.5	26.9	31.8	47.8	85.9
32	1 1/4	38.1	47.8	60.5	82.6	33.3	39.6	60.5	88.9	33.3	39.6	60.5	88.9	33.3	39.6	60.5	104.9
40	1 1/2	44.4	54.1	69.8	95.2	41.4	47.8	69.8	98.6	41.4	47.8	69.8	98.6	41.4	47.8	69.8	117.6
50	2	55.6	69.8	85.9	111.3	52.3	58.7	85.9	143.0	52.3	58.7	85.9	143.0	52.3	58.7	85.9	146.0
65	2 1/2	66.5	82.6	98.6	130.3	63.5	69.8	98.6	165.1	63.5	69.8	98.6	165.1	63.5	69.8	98.6	168.4
80	3	78.7 (81.0)	101.6	120.6	149.4	78.7 (81.0)	95.2	120.6	168.4	78.7 (81.0)	92.2	120.6	174.8	78.7 (81.0)	92.2	120.6	196.8
90	3 1/2	93.7	114.3	133.3	161.9	—	—	—	—	—	—	—	—	—	—	—	—
100	4	102.9 (106.4)	120.6	149.4	193.8	102.9 (106.4)	120.6	149.4	206.5	97.9 (106.4)	117.6	149.4	209.6	97.9 (106.4)	117.6	149.4	235.0
125	5	129.3 (131.8)	147.6	177.8	241.3	129.3 (131.8)	147.6	177.8	247.6	124.5 (131.8)	143.0	177.8	254.0	124.5 (131.8)	143.0	177.8	279.4
150	6	154.9 (157.2)	174.8	209.6	266.7	154.9 (157.2)	174.8	209.6	289.1	147.3 (157.2)	171.4	209.6	282.7	147.3 (157.2)	171.4	209.6	317.5
200	8	205.7 (209.6)	225.6	263.7	320.8	196.8 (209.6)	222.2	257.3	358.9	196.8 (206.2)	215.9	257.3	352.6	196.8 (200.2)	215.9	257.3	387.4
250	10	255.3 (260.4)	274.6	317.5	400.0	246.1 (260.4)	276.4	311.2	435.1	246.1 (257.8)	266.7	311.2	435.1	246.1 (247.6)	270.0	311.2	476.2
300	12	307.3 (317.5)	327.2	374.6	457.2	292.1 (314.5)	323.8	368.3	498.6	292.1 (314.5)	323.8	368.3	520.7	292.1	317.5	368.3	549.4
350	14	342.9 (349.9)	362.0	406.4	492.3	320.8 (332.9)	355.6	400.0	520.7	320.8 (339.9)	362.0	400.0	577.8	—	—	—	—
400	16	389.8 (390.8)	412.8	463.6	565.2	374.9 (393.9)	412.8	457.2	574.8	369.3 (389.3)	406.4	457.2	641.4	—	—	—	—
450	18	438.1 (439.3)	469.9	527.0	612.9	425.4 (443.4)	463.6	520.7	638.3	425.4 (438.2)	463.6	520.7	704.8	—	—	—	—
500	20	488.9 (500.1)	520.7	577.8	682.8	482.5 (495.3)	520.7	571.5	698.5	478.2 (489.6)	514.4	571.5	755.6	—	—	—	—
550	22	552.4	577.8	635.0	733.6	—	—	—	—	—	—	—	—	—	—	—	—
600	24	599.5 (603.2)	628.6	685.8	790.7	599.5 (603.2)	628.6	679.4	838.2	577.8	616.0	679.4	901.7	—	—	—	—

[Dimension Table 17]

Unit [mm]

Nominal flange diameter		Class 150				Class 300·400·600				Class 900				Class 1500			
A	B	Inner ring I.D. D ₁	Main body I.D. D ₂	Main body O.D. D ₃	Outer ring O.D. D ₄	Inner ring I.D. D ₁	Main body I.D. D ₂	Main body O.D. D ₃	Outer ring O.D. D ₄	Inner ring I.D. D ₁	Main body I.D. D ₂	Main body O.D. D ₃	Outer ring O.D. D ₄	Inner ring I.D. D ₁	Main body I.D. D ₂	Main body O.D. D ₃	Outer ring O.D. D ₄
15	1/2	18.2	24.2	34.9	49.1	18.2	24.2	34.9	55.5	18.2	24.2	34.9	65.0	18.2	24.2	34.9	65.0
20	3/4	23.0	29.7	42.9	58.7	23.0	29.7	42.9	68.1	23.0	29.7	42.9	71.4	23.0	29.7	42.9	71.4
25	1	30.0	36.5	50.8	68.2	30.0	36.5	50.8	74.5	30.0	36.5	50.8	80.9	30.0	36.5	50.8	80.9
(32)	(1 1/4)	—	—	—	—	—	—	—	—	33.3	46.0	63.5	90.4	33.3	46.0	63.5	90.4
40	1 1/2	—	—	—	—	—	—	—	—	41.4	50.8	73.2	100.1	41.4	50.8	73.2	100.1
50	2	—	—	—	—	—	—	—	—	52.3	63.5	91.9	144.5	52.3	63.5	91.9	144.5
65	2 1/2	—	—	—	—	—	—	—	—	63.5	79.5	104.6	166.6	63.5	79.5	104.6	166.6
350	14	—	—	—	—	—	—	—	—	342.9	363.0	400.0	520.7	—	—	—	—

*This dimension table has been prepared by Nichias, based on JPI-7S-15-1999 "Flanges for the Petroleum Industry."

*It is recommended that all bolts be made of alloy steel (high strength bolts of SNB-7 or higher).

*The O.D. of the body of a gasket with an outer ring and an inner ring is expressed as the dimension of the convex part excluding spring layers.

For JPI pipe large bore flange series B

VORTEX™ gaskets (65A - 1500A) with (inner) outer ring

■ Applicable gaskets

GRASEAL™ VORTEX™, NA VORTEX™, NAFLON™ VORTEX™,
VORTEX™ gaskets -GS, -GM, -GH

■ Applicable standard

JPI-7S-41-2005 "VORTEX™ Gaskets for Pipes" Appendix Tables
5 Reference Appendix Table 1 Dimensions
Values in parentheses () in the Dimension Table are in (Old) JPI-
7S-41-1990 Appendix Table 3.

■ Applicable flanges

JPI-7S-15 "Forged Steel Flanges for the Petroleum Industry"
JPI-7S-43 "Large Bore Flanges" Series B
ANSI B 16.5-1981 "Steel Pipe Flanges"
ASME B 16.47-1996 "Large-Diameter Steel Flanges, series B"
API-Std 605-1980 "Large-Diameter Carbon Steel Flanges"

[Dimension Table 18-1]

Unit [mm]

Normal flange diameter		Class 150				Class 300			
A	B	Inner ring I.D. D ₁	Main body I.D. D ₂	Main body O.D. D ₃	Outer ring O.D. D ₄	Inner ring I.D. D ₁	Main body I.D. D ₂	Main body O.D. D ₃	Outer ring O.D. D ₄
650	26	654.0	673.1	698.5	725.4	654.0	673.1	711.2	771.7
700	28	704.8	723.9	749.3	776.2	704.8	723.9	762.0	825.5
750	30	755.6	774.7	800.1	827.0	755.6	774.7	812.8	886.0
800	32	806.4	825.5	850.9	881.1	806.4	825.5	863.6	939.8
850	34	857.2	876.3	908.0	935.0	857.2	876.3	914.4	993.9
900	36	908.0	927.1	958.8	987.6	908.0	927.1	965.2	1,047.8
950	38	958.8	974.6	1,009.6	1,044.7	971.6	1,009.6	1,047.8	1,098.6
1,000	40	1,009.6	1,022.4	1,063.8	1,095.5	1,022.4	1,060.4	1,098.6	1,149.4
1,050	42	1,060.4	1,079.5	1,114.6	1,146.3	1,085.8	1,111.2	1,149.4	1,200.2
1,100	44	1,111.2	1,124.0	1,165.4	1,197.1	1,124.0	1,162.0	1,200.2	1,251.0
1,150	46	1,162.0	1,181.1	1,224.0	1,255.8	1,178.1	1,216.2	1,254.3	1,317.8
1,200	48	1,212.8	1,231.9	1,270.0	1,306.6	1,231.9	1,263.6	1,311.4	1,368.6
1,250	50	1,263.6	1,282.7	1,325.6	1,357.4	1,267.0	1,317.8	1,355.9	1,419.4
1,300	52	1,314.4	1,333.5	1,376.4	1,408.2	1,317.8	1,368.6	1,406.7	1,470.2
1,350	54	1,365.2	1,384.3	1,422.4	1,463.8	1,365.2	1,403.4	1,454.2	1,530.4
1,400	56	1,422.4	1,444.8	1,477.8	1,514.6	1,428.8	1,479.6	1,524.0	1,593.8
1,450	58	1,478.0	1,500.4	1,528.8	1,579.6	1,484.4	1,535.2	1,573.3	1,655.8
1,500	60	1,535.2	1,557.3	1,586.0	1,630.4	1,557.3	1,589.0	1,630.4	1,706.6

[Dimension Table 18-2]

Unit [mm]

Normal flange diameter		Class400				Class600				Class 900			
A	B	Inner ring I.D. D ₁	Main body I.D. D ₂	Main body O.D. D ₃	Outer ring O.D. D ₄	Inner ring I.D. D ₁	Main body I.D. D ₂	Main body O.D. D ₃	Outer ring O.D. D ₄	Inner ring I.D. D ₁	Main body I.D. D ₂	Main body O.D. D ₃	Outer ring O.D. D ₄
650	26	654.0	666.8	698.5	746.3	644.7	663.7	714.5	765.3	673.1	692.2	749.3	838.2
700	28	701.8	714.5	749.3	800.1	692.2	704.8	755.6	819.2	723.9	743.0	800.1	901.7
750	30	752.6	765.3	806.4	857.2	752.6	778.0	828.8	879.6	787.4	806.4	857.2	958.8
800	32	800.1	812.8	860.6	911.4	793.8	831.8	882.6	933.4	838.2	863.6	914.4	1,016.0
850	34	850.9	866.9	911.4	962.2	850.9	889.0	939.8	997.0	895.4	920.8	971.6	1,073.2
900	36	898.7	917.7	965.2	1,022.4	901.7	939.8	990.6	1,047.8	927.1	946.2	997.0	1,124.0
950	38	(952.5)	(971.6)	(1,022.4)	(1,073.2)	(952.5)	(990.6)	(1,041.4)	(1,104.9)	1,009.6	1,035.0	1,085.8	1,200.2
1,000	40	(1,000.2)	(1,025.6)	(1,076.4)	(1,127.2)	(1,009.6)	(1,047.8)	(1,098.6)	(1,155.7)	1,060.4	1,098.6	1,149.4	1,251.0
1,050	42	(1,051.0)	(1,076.4)	(1,127.2)	(1,178.0)	(1,066.8)	(1,104.9)	(1,155.7)	(1,219.2)	1,111.2	1,149.4	1,200.2	1,301.8
1,100	44	(1,104.9)	(1,130.3)	(1,181.1)	(1,231.9)	(1,111.2)	(1,162.0)	(1,212.8)	(1,270.0)	1,155.7	1,206.5	1,257.3	1,368.6
1,150	46	(1,168.4)	(1,193.8)	(1,244.6)	(1,289.0)	(1,162.0)	(1,212.8)	(1,263.6)	(1,327.2)	1,219.2	1,270.0	1,320.8	1,435.1
1,200	48	(1,206.5)	(1,244.6)	(1,295.4)	(1,346.2)	(1,219.2)	(1,270.0)	(1,320.8)	(1,390.6)	1,270.0	1,320.8	1,371.6	1,485.9
1,250	50	(1,257.3)	(1,295.4)	(1,346.2)	(1,403.4)	(1,270.0)	(1,320.8)	(1,371.6)	(1,447.8)	—	—	—	—
1,300	52	(1,308.1)	(1,346.2)	(1,397.0)	(1,454.2)	(1,320.8)	(1,371.6)	(1,422.4)	(1,498.6)	—	—	—	—
1,350	54	(1,352.6)	(1,403.4)	(1,454.2)	(1,517.6)	(1,378.0)	(1,428.8)	(1,479.6)	(1,555.8)	—	—	—	—
1,400	56	(1,403.4)	(1,454.2)	(1,505.0)	(1,568.4)	(1,428.8)	(1,479.6)	(1,530.4)	(1,612.9)	—	—	—	—
1,450	58	(1,454.2)	(1,505.0)	(1,555.8)	(1,619.2)	(1,473.2)	(1,536.7)	(1,587.5)	(1,663.7)	—	—	—	—
1,500	60	(1,517.6)	(1,568.4)	(1,619.2)	(1,682.8)	(1,530.4)	(1,593.8)	(1,644.6)	(1,733.6)	—	—	—	—

*Use high-strength alloy steel bolts of SNB-7 or higher.

*When using this type of gasket on a slip-on welded flange, the inner ring I.D. may sometimes protrude from the I.D. of the flange, so please use caution. The use of a butt-welded flange is recommended.

*: When using this type of gasket on a flange that has a nominal pressure of at least Class 900, it is recommended that you use a gasket with inner and outer rings.

*In the case of a large bore flange that has a nominal diameter of at least 26B (650A), it is recommended that a gasket with inner and outer rings be used.

Basic type VORTEX™ gaskets with inner ring

■ **Applicable gaskets**

GRASEAL™ VORTEX™, NA VORTEX™, NAFLON™ VORTEX™, VORTEX™ gaskets -GS, -GM, -GH

■ **Applicable standard**

JPI-7S-41-2005 "VORTEX™ Gaskets for Pipes" Appendix Table 6 Dimensions

Values in parentheses [] in the Dimension Table are in (Old) JPI-7S-41-1998.

■ **Applicable flanges**

JPI-7S-15 "Forged Steel Flanges for the Petroleum Industry" ANSI B 16.5 "Pipe Flanges and Flanged Fittings"

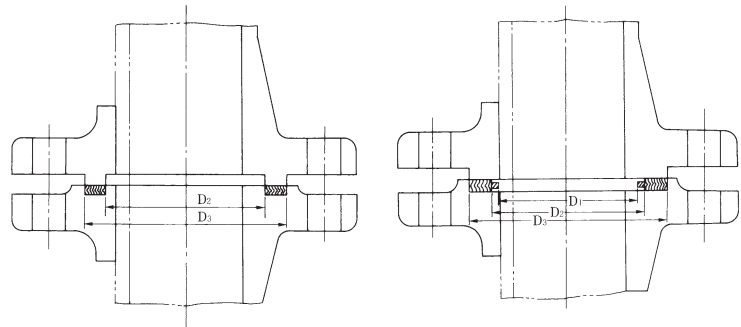

Large tongue and groove seat

Large male and female seat

[Dimension Table 19]

Unit [mm]

Nominal flange diameter		Inner ring I.D. D ₁					I.D. D ₂	O.D. D ₃
A	B	Class 300	Class 400 Class 600	Class 900	Class 1500	Class 2500		
15	1/2	14.2	14.2	14.2	14.2	14.2	25.1	35.4
20	3/4	20.6	20.6	20.6	20.6	20.6	33.0	43.2
25	1	26.9	26.9	26.9	26.9	26.9	37.8	51.1
32	1 1/4	38.1	38.1	33.3	33.3	33.3	47.2	63.8
40	1 1/2	44.4	44.4	41.4	41.4	41.4	53.5	73.5
50	2	55.6	55.6	52.3	52.3	52.3	72.6	92.5
65	2 1/2	66.5	66.5	63.5	63.5	63.5	85.3	105.2
80	3	81.0	81.0	78.7 (81.0)	78.7 (81.0)	78.7 (81.0)	107.6	127.3
90	3 1/2	93.7	93.7	—	—	—	120.3	140.0
100	4	106.4	102.6 (106.4)	102.6 (106.4)	97.8 (106.4)	97.8 (106.4)	131.2	157.6
125	5	131.8	128.3 (131.8)	128.3 (131.8)	124.5 (131.8)	124.5 (131.8)	160.0	186.3
150	6	157.2	154.9 (157.2)	154.9 (157.2)	147.3 (157.2)	147.3 (157.2)	190.2	216.3
200	8	215.9	205.7 (209.6)	196.8 (209.6)	196.8 (206.2)	196.8 (200.2)	237.7	270.0
250	10	268.2	255.3 (260.4)	246.1 (260.4)	246.1 (257.8)	246.1 (247.6)	285.7	323.9
300	12	317.5	307.3 (317.5)	292.1 (314.5)	292.1 (314.5)	291.1 (292.1)	342.9	381.0
350	14	349.2	342.9 (349.2)	320.8 (342.9)	320.8 (339.8)	—	374.6	412.8
400	16	400.0	389.9 (400.0)	374.6 (393.7)	368.3 (387.4)	—	425.4	469.9
450	18	449.3	438.1 (449.3)	425.4 (444.5)	425.4 (438.2)	—	488.9	533.4
500	20	500.1	488.9 (500.1)	482.6 (495.3)	476.2 (489.0)	—	533.4	584.2
600	24	603.2	590.5 (603.2)	590.5 (603.2)	577.8	—	641.8	691.7

*It is recommended that the depth of the groove in the seat should be at least 5.5mm, taking into consideration the allowable thickness of the gasket.

*Neither a large male and female seat nor a large tongue and groove seat exists in Class 150.

* [] : When using a large male and female seat of Class 900 or higher, we recommend to use a gasket that has an inner ring, regardless of the type of filler material used.

*It is recommended that high-strength alloy steel bolts of SNB-7 or higher to be used.

VORTEX™ gaskets with inner and outer rings

■ **Applicable gaskets**

GRASEAL™ VORTEX™, NA VORTEX™, NAFLON™ VORTEX™, VORTEX™ gaskets -GS, -GM and -GH

■ **Applicable standard**

JPI-7S-41-1998 "VORTEX™ Gaskets for Pipes" Appendix Table 4 Dimensions

■ **Applicable flange**

JPI-7S-43 "Large Bore Flanges for the Petroleum Industry"
MSS-SP-44 "Steel Pipe Line Flanges"

[Dimension Table 22]

Unit [mm]

Nominal flange diameter	Class 150				Class 300				Class 400			
	Inner ring I.D. D ₁	I.D. D ₂	O.D. D ₃	Outer ring O.D. D ₄	Inner ring I.D. D ₁	I.D. D ₂	O.D. D ₃	Outer ring O.D. D ₄	Inner ring I.D. D ₁	I.D. D ₂	O.D. D ₃	Outer ring O.D. D ₄
26B	654.0	673.1	704.8	774.7	654.0	685.8	736.6	835.2	660.4	685.8	736.6	831.8
28	704.8	723.9	755.6	831.8	704.8	736.6	787.4	898.7	711.2	736.6	787.4	892.3
30	755.6	774.7	806.4	882.6	755.6	793.8	844.6	952.5	755.6	793.8	844.6	946.2
32	806.4	825.5	860.6	939.8	806.4	850.9	901.7	1,006.6	812.8	850.9	901.7	1,003.3
34	857.2	876.3	911.4	990.6	857.2	901.7	952.5	1,057.4	863.6	901.7	952.5	1,054.1
36	908.0	927.1	968.5	1,047.8	908.0	955.8	1,006.6	1,117.6	917.7	955.8	1,006.6	1,117.6
38	958.8	977.9	1,019.3	1,111.2	952.5	977.9	1,016.0	1,054.1	952.5	971.6	1,022.4	1,073.2
40	1,009.6	1,028.7	1,070.1	1,162.0	1,003.3	1,022.4	1,070.1	1,114.6	1,000.3	1,025.7	1,076.5	1,127.3
42	1,060.4	1,079.5	1,124.0	1,219.2	1,054.1	1,073.2	1,120.9	1,165.4	1,051.1	1,076.5	1,127.3	1,178.1
44	1,111.2	1,130.3	1,178.1	1,276.4	1,104.9	1,130.3	1,181.1	1,219.2	1,104.9	1,130.3	1,181.1	1,231.9
46	1,162.0	1,181.1	1,228.9	1,327.2	1,152.7	1,178.1	1,228.9	1,273.3	1,168.4	1,193.8	1,244.6	1,289.0
48	1,212.8	1,231.9	1,279.7	1,384.3	1,209.8	1,235.2	1,286.0	1,324.1	1,206.5	1,244.6	1,295.4	1,346.2
50	1,263.6	1,282.7	1,333.5	1,435.1	1,244.6	1,295.4	1,346.2	1,378.0	1,257.3	1,295.4	1,346.2	1,403.4
52	1,314.4	1,333.5	1,384.3	1,492.2	1,320.8	1,346.2	1,397.0	1,428.8	1,308.1	1,346.2	1,397.0	1,454.2
54	1,358.9	1,384.3	1,435.1	1,549.4	1,352.6	1,403.4	1,454.2	1,492.2	1,352.6	1,403.4	1,454.2	1,517.6
56	1,409.7	1,435.1	1,485.9	1,606.6	1,403.4	1,454.2	1,505.0	1,543.0	1,403.4	1,454.2	1,505.0	1,568.4
58	1,460.5	1,485.9	1,536.7	1,663.7	1,447.8	1,511.3	1,562.1	1,593.8	1,454.2	1,505.0	1,555.8	1,619.2
60	1,511.3	1,536.7	1,587.5	1,714.5	1,524.0	1,562.1	1,612.9	1,644.6	1,517.6	1,568.4	1,619.2	1,682.8

*Use a butt-welded type flange.

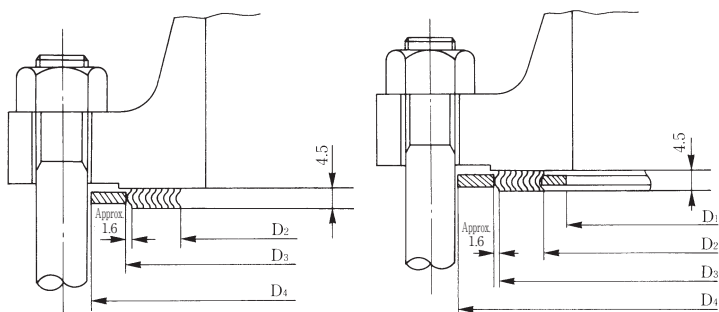

*The O.D. of the main body is expressed as the dimension of the convex part excluding spring layers.

Unit [mm]

Nominal flange diameter	Class 600				Class 900			
	Inner ring I.D. D ₁	I.D. D ₂	O.D. D ₃	Outer ring O.D. D ₄	Inner ring I.D. D ₁	I.D. D ₂	O.D. D ₃	Outer ring O.D. D ₄
26B	647.7	685.8	736.6	866.9	666.8	685.8	736.6	882.6
28	698.5	736.6	787.4	914.4	711.2	736.6	787.4	946.2
30	755.6	793.8	844.6	971.6	774.7	793.8	844.6	1,009.6
32	812.8	850.9	901.7	1,022.4	812.8	850.9	901.7	1,073.2
34	863.6	901.7	952.5	1,073.2	863.6	901.7	952.5	1,136.6
36	917.7	955.8	1,006.6	1,130.3	920.8	958.8	1,009.6	1,200.2
38	952.5	990.6	1,041.4	1,104.9	1,009.6	1,035.0	1,085.8	1,200.2
40	1,009.6	1,047.8	1,098.6	1,155.7	1,060.4	1,098.6	1,149.4	1,251.0
42	1,066.8	1,104.9	1,155.7	1,219.2	1,111.2	1,149.4	1,200.2	1,301.8
44	1,111.2	1,162.0	1,212.8	1,270.0	1,155.7	1,206.5	1,257.3	1,368.6
46	1,162.0	1,212.8	1,263.6	1,327.2	1,219.2	1,270.0	1,320.8	1,435.1
48	1,219.2	1,270.0	1,320.8	1,390.6	1,270.0	1,320.8	1,371.6	1,485.9
50	1,270.0	1,320.8	1,371.6	1,447.8	—	—	—	—
52	1,320.8	1,371.6	1,422.4	1,498.6	—	—	—	—
54	1,378.0	1,428.8	1,479.6	1,555.8	—	—	—	—
56	1,428.8	1,479.6	1,530.4	1,612.9	—	—	—	—
58	1,473.2	1,536.7	1,587.5	1,663.7	—	—	—	—
60	1,530.4	1,593.8	1,644.6	1,733.6	—	—	—	—

VORTEX™ gasket outer ring in the case where metric thread bolts are used

■ Applicable gaskets

GRASEAL™ VORTEX™, NA VORTEX™, NAFLON™ VORTEX™, VORTEX™ gaskets -GS, -GM, -GH

■ Applicable standard

JPI-7S-41-2005 "VORTEX™ Gaskets for Pipes" Appendix, Appendix Tables 1, 2, Appendix, Reference Appendix Table 1 Dimensions

[Dimension Table 20]

Unit [mm]

Nominal diameter		Class 150		Class 300		Class 400		Class 600	
A	B	Nominal size of metric screw thread bolts	Outer ring O.D. D ₄	Nominal size of metric screw thread bolts	Outer ring O.D. D ₄	Nominal size of metric screw thread bolts	Outer ring O.D. D ₄	Nominal size of metric screw thread bolts	Outer ring O.D. D ₄
15	1/2	M14	45.5	M14	51.5	M14	51.5	M14	51.5
20	3/4	M14	54.8	M16	65.6	M16	65.6	M16	65.6
25	1	M14	64.2	M16	71.9	M16	71.9	M16	71.9
32	1 1/4	M14	73.9	M16	81.6	M16	81.6	M16	81.6
40	1 1/2	M14	83.6	M20	93.3	M20	93.3	M20	93.3
50	2	M16	103.6	M16	110.0	M16	110.0	M16	110.0
65	2 1/2	M16	122.7	M20	128.4	M20	128.4	M20	128.4
80	3	M16	135.4	M20	147.1	M20	147.1	M20	147.1
90	3 1/2	M16	160.8	M20	163.2	M24	159.2	M24	159.2
100	4	M16	173.5	M20	179.2	M24	175.2	M24	190.9
125	5	M20	194.9	M20	214.0	M24	210.0	M27	238.7
150	6	M20	220.3	M20	248.7	M24	244.7	M27	264.1
200	8	M20	277.4	M24	305.2	M27	302.2	M30 × 3	318.2
250	10	M24	337.0	M27	359.4	M30 × 3	356.4	M33 × 3	397.8
300	12	M24	406.8	M30 × 3	419.8	M33 × 3	416.8	M33 × 3	455.0
350	14	M27	448.2	M30 × 3	483.4	M33 × 3	480.4	M36 × 3	490.0
400	16	M27	511.8	M33 × 3	537.5	M36 × 3	534.5	M39 × 3	563.2
450	18	M30 × 3	546.8	M33 × 3	594.6	M36 × 3	591.6	M42 × 3	611.0
500	20	M30 × 3	604.0	M33 × 3	651.8	M39 × 3	645.8	M42 × 3	680.9
550	22	M33 × 3	659.2	M39 × 3	704.0	M42 × 3	701.0	M45 × 3	732.7
600	24	M33 × 3	715.3	M39 × 3	772.8	M45 × 3	766.8	M48 × 3	789.2

*It is recommended that all bolts be made of alloy steel (high strength bolts of SNB-7 or higher).

*The values inside the bold border **□** cannot be used for a slip-on welded flange.

*The inner ring I.D. of the gasket may sometimes protrude from the I.D. of the flange, so please use caution.

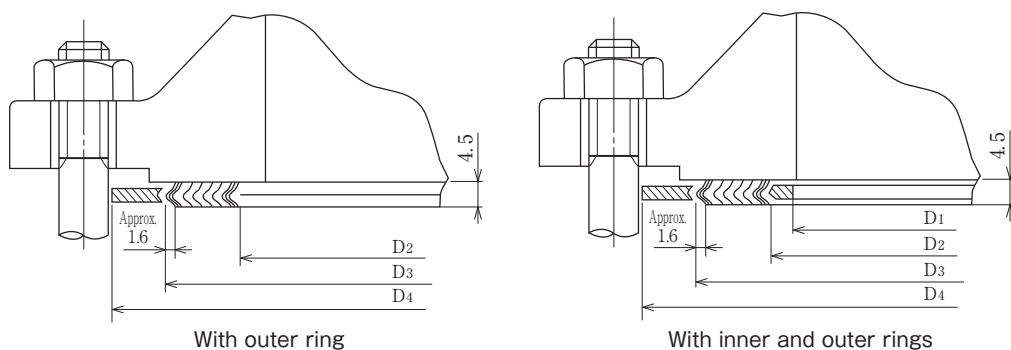

With outer ring

With inner and outer rings

*The O.D. dimension of the body of a gasket with an outer ring is expressed as the dimension of the convex part excluding spring layers.

Unit [mm]

Nominal diameter		Class 900		Class 1500		Class 2500	
A	B	Nominal size of metric screw thread bolts	Outer ring O.D. D ₄	Nominal size of metric screw thread bolts	Outer ring O.D. D ₄	Nominal size of metric screw thread bolts	Outer ring O.D. D ₄
15	1/2	M20	61.6	M20	61.6	M20	67.9
20	3/4	M20	67.9	M20	67.9	M20	74.2
25	1	M24	76.6	M24	76.6	M24	83.0
32	1 1/4	M24	86.3	M24	86.3	M27	102.0
40	1 1/2	M27	96.0	M27	96.0	M30 × 3	115.0
50	2	M24	140.1	M24	140.1	M27	143.4
65	2 1/2	M27	162.5	M27	162.5	M30 × 3	165.8
80	3	M24	165.5	M30 × 3	172.2	M33 × 3	194.6
90	3 1/2	—	—	—	—	—	—
100	4	M30 × 3	204.0	M33 × 3	207.3	M39 × 3	233.0
125	5	M33 × 3	245.4	M39 × 3	252.1	M45 × 3	277.8
150	6	M30 × 3	286.5	M36 × 3	280.5	M52 × 3	315.3
200	8	M36 × 3	356.7	M42 × 3	350.7	M52 × 3	385.2
250	10	M36 × 3	432.9	M48 × 3	433.6	M64 × 3	474.8
300	12	M36 × 3	496.4	M52 × 3	518.5	M70 × 3	548.3
350	14	M39 × 3	518.8	M56 × 3	578.0	—	—
400	16	M42 × 3	573.0	M64 × 3	639.8	—	—
450	18	M48 × 3	636.8	M70 × 3	703.7	—	—
500	20	M52 × 3	696.3	M76 × 3	754.8	—	—
600	24	M64 × 3	836.7	M90 × 3	899.6	—	—

VORTEX™ gaskets with (inner) outer ring

■ **Applicable gaskets**

GRASEAL™ VORTEX™, NA VORTEX™, NAFLON™ VORTEX™, VORTEX™ gaskets -GS, -GM, -GH

■ **Applicable standard**

ASME B16.5 "METALLIC GASKETS FOR PIPE FLANGES" TABLE 9, 12 Dimensions

■ **Applicable flange**

ASME B16.5 "Pipe Flanges and Flanged Fittings"

[Dimension table 21]

Unit [mm]

Nominal diameter	Class 150			Class 300			Class 400			Class 600						
	Inner ring I.D. D ₁	Main body I.D. D ₂ O.D. D ₃		Outer ring O.D. D ₄	Inner ring I.D. D ₁	Main body I.D. D ₂ O.D. D ₃		Outer ring O.D. D ₄	Inner ring I.D. D ₁	Main body I.D. D ₂ O.D. D ₃		Outer ring O.D. D ₄				
1/2	14.2	19.1	31.8	47.8	14.2	19.1	31.8	54.1	Use a Class 600 flange gasket.				14.2	19.1	31.8	54.1
3/4	20.6	25.4	39.6	57.2	20.6	25.4	39.6	66.8					20.6	25.4	39.6	66.8
1	26.9	31.8	47.8	66.8	26.9	31.8	47.8	73.2					26.9	31.8	47.8	73.2
1 1/4	38.1	47.8	60.5	76.2	38.1	47.8	60.5	82.6					38.1	47.8	60.5	82.6
1 1/2	44.5	54.1	69.9	85.9	44.5	54.1	69.9	95.3					44.5	54.1	69.9	95.3
2	55.6	69.9	85.9	104.9	55.6	69.9	85.9	111.3					55.6	69.9	85.9	111.3
2 1/2	66.5	82.6	98.6	124.0	66.5	82.6	98.6	130.3					66.5	82.6	98.6	130.3
3	81.0	101.6	120.7	136.7	81.0	101.6	120.7	149.4					81.0	101.6	120.7	149.4
4	106.4	127.0	149.4	174.8	106.4	127.0	149.4	181.1	102.6	120.7	149.4	177.8	102.6	120.7	149.4	193.8
5	131.8	155.7	177.8	196.9	131.8	155.7	177.8	215.9	128.3	147.6	177.8	212.9	128.3	147.6	177.8	241.3
6	157.2	182.6	209.6	222.3	157.2	182.6	209.6	251.0	154.9	174.8	209.6	247.7	154.9	174.8	209.6	266.7
8	215.9	233.4	263.7	279.4	215.9	233.4	263.7	308.1	205.7	225.6	263.7	304.8	205.7	225.6	263.7	320.8
10	268.2	287.3	317.5	339.9	268.2	287.3	317.5	362.0	255.3	274.6	317.5	358.9	255.3	274.6	317.5	400.1
12	317.5	339.9	374.7	409.7	317.5	339.9	374.7	422.4	307.3	327.2	374.7	419.1	307.3	327.2	374.7	457.2
14	349.3	371.6	406.4	450.9	349.3	371.6	406.4	485.9	342.9	362.0	406.4	482.6	342.9	362.0	406.4	492.3
16	400.1	422.4	463.6	514.4	400.1	422.4	463.6	539.8	389.9	412.8	463.6	536.7	389.9	412.8	463.6	565.2
18	449.3	474.7	527.1	549.4	449.3	474.7	527.1	596.9	438.2	469.9	527.1	593.9	438.2	469.9	527.1	612.9
20	500.1	525.5	577.9	606.6	500.1	525.5	577.9	654.1	489.0	520.7	577.9	647.7	489.0	520.7	577.9	682.8
24	603.3	628.7	685.8	717.6	603.3	628.7	685.8	774.7	590.6	628.7	685.8	768.4	590.6	628.7	685.8	790.7

*It is recommended that all bolts be made of alloy steel (high strength bolts of SNB-7 or higher).

*ASME B16.20-1998 stipulates a smaller inner ring I.D. for some sizes, so please use caution.

*Class 400 nominal diameters of 1/2 - 3B gaskets do not exist, therefore a Class 600 flange gasket shall be used instead.

*Class 900 nominal diameter 1/2 - 2 1/2B gaskets do not exist, therefore a Class 1500 flange gasket shall be used instead.

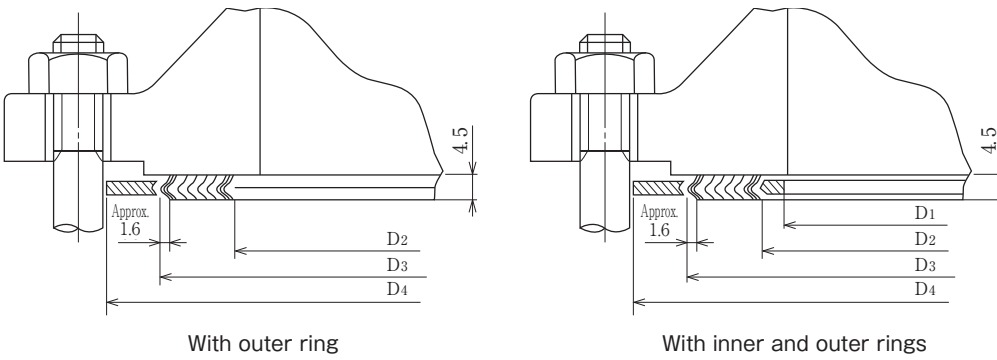

*The O.D. of the body of a gasket with an outer ring and an inner ring is expressed as the dimension of the convex part excluding spring layers.

Unit [mm]

Nominal diameter	Class 900				Class 1500				Class 2500			
	Inner ring I.D. D ₁	Main body		Outer ring O.D. D ₄	Inner ring I.D. D ₁	Main body		Outer ring O.D. D ₄	Inner ring I.D. D ₁	Main body		Outer ring O.D. D ₄
		I.D. D ₂	O.D. D ₃			I.D. D ₂	O.D. D ₃			I.D. D ₂	O.D. D ₃	
1/2	Use a Class 1500 flange gasket.				14.2	19.1	31.8	63.5	14.2	19.1	31.8	69.9
3/4					20.6	25.4	39.6	69.9	20.6	25.4	39.6	76.2
1					26.9	31.8	47.8	79.5	26.9	31.8	47.8	85.9
1 1/4					33.3	39.6	60.5	88.9	33.3	39.6	60.5	104.9
1 1/2					41.4	47.8	69.9	98.6	41.4	47.8	69.9	117.6
2					52.3	58.7	85.9	143.0	52.3	58.7	85.9	146.1
2 1/2					63.5	69.9	98.6	165.1	63.5	69.9	98.6	168.4
3	78.7	95.3	120.7	168.4	78.7	92.2	120.7	174.8	78.7	92.2	120.7	196.9
4	102.6	120.7	149.4	206.5	97.8	117.6	149.4	209.6	97.8	117.6	149.4	235.0
5	128.3	147.6	177.8	247.7	124.5	143.0	177.8	254.0	124.5	143.0	177.8	279.4
6	154.9	174.8	209.6	289.1	147.3	171.5	209.6	282.7	147.3	171.5	209.6	317.5
8	196.9	222.3	257.3	358.9	196.9	215.9	257.3	352.6	196.9	215.9	257.3	387.4
10	246.1	276.4	311.2	435.1	246.1	266.7	311.2	435.1	246.1	270.0	311.2	476.3
12	292.1	323.9	368.3	498.6	292.1	323.9	368.3	520.7	292.1	317.5	368.3	549.4
14	320.8	355.6	400.1	520.7	320.8	362.0	400.1	577.9	—	—	—	—
16	374.7	412.8	457.2	574.8	368.3	406.4	457.2	641.4	—	—	—	—
18	425.5	463.6	520.7	638.3	425.5	463.6	520.7	704.9	—	—	—	—
20	482.6	520.7	571.5	698.5	476.3	514.4	571.5	755.7	—	—	—	—
24	590.6	628.7	679.5	838.2	577.9	616.0	679.5	901.7	—	—	—	—

VORTEX™ gaskets with inner and outer rings

■ Applicable gaskets

GRASEAL™ VORTEX™, NA VORTEX™, NAFLON™ VORTEX™, VORTEX™ gaskets -GS, -GM and -GH

■ Applicable flanges⁽¹⁾

TAYLOR FORGE Classes 175, 350, 125, 250, LADISH Classes 150, 300

Note: (1) For TAYLOR FORGE Class 150, use Standard Dimension Table 19.

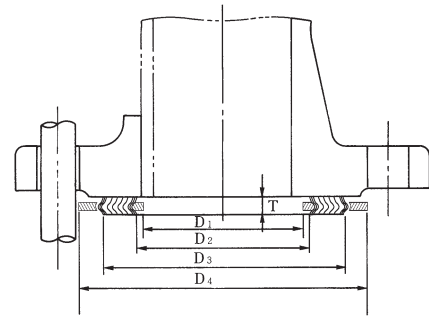

[Dimension Table 23]

Unit [mm]

Nominal flange diameter	TAYLOR FORGE Class 175				TAYLOR FORGE Class 350			
	LADISH Class 150				LADISH Class 300			
	Inner ring I.D. D ₁	I.D. D ₂	O.D. D ₃	Outer ring O.D. D ₄	Inner ring I.D. D ₁	I.D. D ₂	O.D. D ₃	Outer ring O.D. D ₄
26B	660	680	703	740	660	680	712	752
28	711	731	754	791	711	731	763	803
30	762	782	809	848	762	782	814	860
32	813	833	860	899	813	833	865	911
34	864	884	915	952	864	884	916	962
36	914	934	965	1,003	914	934	966	1,026
38	965	985	1,016	1,054	965	985	1,017	1,076
40	1,016	1,041	1,074	1,105	1,016	1,041	1,081	1,127
42	1,067	1,092	1,130	1,165	1,067	1,092	1,132	1,184
44	1,118	1,143	1,181	1,216	1,118	1,143	1,183	1,245
46	1,168	1,193	1,231	1,267	1,168	1,193	1,233	1,295
48	1,219	1,244	1,282	1,318	1,219	1,244	1,284	1,346
50	1,270	1,295	1,333	1,368	—	—	—	—
52	1,321	1,346	1,386	1,426	1,321	1,351	1,401	1,457
54	1,372	1,397	1,437	1,476	1,372	1,402	1,452	1,508
60	1,524	1,549	1,589	1,629	1,524	1,554	1,604	1,661
66	1,676	1,706	1,746	1,781	1,702	1,742	1,782	1,842
72	1,829	1,859	1,899	1,946	1,854	1,894	1,934	1,994
84	2,162	2,202	2,232	2,292	2,197	2,237	2,267	2,327
96	2,467	2,507	2,537	2,597	2,512	2,552	2,582	2,642

Nominal flange diameter	TAYLOR FORGE Class 125				TAYLOR FORGE Class 250			
	Inner ring I.D. D ₁	I.D. D ₂	O.D. D ₃	Outer ring O.D. D ₄	Inner ring I.D. D ₁	I.D. D ₂	O.D. D ₃	Outer ring O.D. D ₄
26B	650	675	725	774	650	675	725	831
28	701	726	776	831	701	726	776	895
30	752	777	827	882	752	777	827	952
32	803	828	878	939	803	828	878	1,009
34	854	879	929	990	854	879	929	1,060
36	904	929	979	1,047	904	929	979	1,117
38	955	985	1,035	1,111	955	985	1,035	1,168
40	1,006	1,036	1,086	1,162	1,006	1,036	1,086	1,225
42	1,057	1,087	1,137	1,219	1,057	1,087	1,137	1,289
44	1,108	1,138	1,188	1,276	1,108	1,138	1,188	1,346
46	1,158	1,188	1,238	1,327	1,158	1,188	1,238	1,403
48	1,209	1,239	1,289	1,384	1,209	1,239	1,289	1,492
50	1,260	1,290	1,340	1,435	—	—	—	—
52	1,311	1,341	1,391	1,492	—	—	—	—
54	1,362	1,392	1,442	1,549	—	—	—	—
60	1,514	1,544	1,594	1,714	—	—	—	—
66	1,745	1,785	1,825	1,885	—	—	—	—
72	1,911	1,951	1,991	2,051	—	—	—	—
84	2,244	2,284	2,314	2,374	—	—	—	—
96	2,568	2,608	2,638	2,698	—	—	—	—

*This dimension table has been prepared by Nichias.

*It is recommended that a gasket fitted with inner and outer rings be used for all nominal pressure values.

*It is recommended that high-strength alloy steel bolts of SNB-7 or higher to be used.

GRASEAL™ VORTEX™ gaskets -L with (inner) outer ring

■ Applicable gasket
GRASEAL™ VORTEX™ -L

■ Applicable flanges
JPI-7S-15 "Flanges for the Petroleum Industry"
ASME B16.5-1998 "Pipe Flanges and Flanged Fittings"
MSS-SP-44-1990 "Steel Pipe Line Flanges"

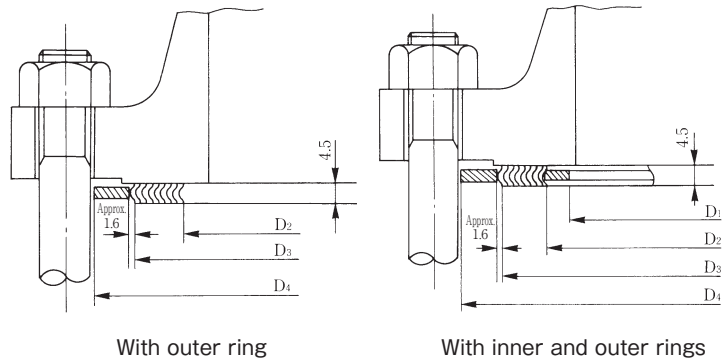

[Dimension Table 24]

Unit [mm]

Nominal diameter	Class 150				Class 300				Class 600			
	Inner ring I.D. D ₁	Main body		Outer ring O.D. D ₄	Inner ring I.D. D ₁	Main body		Outer ring O.D. D ₄	Inner ring I.D. D ₁	Main body		Outer ring O.D. D ₄
		I.D.D ₂	O.D. D ₃			I.D.D ₂	O.D. D ₃			I.D.D ₂	O.D. D ₃	
1/2	17	23	33	47	17	23	33	53	17	23	33	53
3/4	23	29	41	57	23	29	41	66	23	29	41	66
1	30	36	48	66	30	36	48	73	30	36	48	73
1 1/4	41	47	60	76	41	47	60	82	41	47	60	82
1 1/2	45	53	68	85	45	53	68	95	45	53	68	95
2	58	66	82	104	58	66	82	111	58	66	82	111
2 1/2	71	81	97	123	71	81	97	129	71	81	97	129
3	91	101	117	136	91	101	117	148	89	99	117	148
3 1/2	100	112	130	162	100	112	130	164	98	110	130	161
4	115	127	146	174	115	127	146	180	109	121	146	193
5	141	155	175	196	141	153	175	215	135	147	175	241
6	170	186	206	222	166	182	206	250	158	174	206	266
8	220	240	260	279	220	236	260	307	209	230	260	320
10	271	290	314	339	267	287	314	360	254	274	314	400
12	321	347	371	409	321	341	371	420	309	329	371	457
14	351	377	403	450	351	371	403	484	339	366	403	492
16	402	424	460	514	402	422	460	539	392	420	460	564
18	465	487	523	549	455	483	523	595	448	483	523	612
20	514	534	574	606	504	534	574	652	495	534	574	682
24	620	642	682	717	610	642	682	774	603	642	682	790

*This dimension table has been prepared by Nichias.

Ring joint gaskets

Ring joints

■ Applicable gasket

Ring joint gasket "TOMBO™ No.1850C, 1850V"

■ Applicable standard

JPI-7S-23-1998

"Ring Joint Gaskets for the Petroleum Industry, and Grooves"

■ Applicable flanges

JPI-7S-15 "Forged Steel Flanges for the Petroleum Industry"

JPI-7S-43 "Large Bore Flanges for the Petroleum Industry"

ASME B16.5 "Pipe Flanges and Flanged Fittings"

ANSI B 16.5 "Steel pipe Flange"

API Spec 6A "Wellhead Equipment"

MSS-SP-44 "Steel Pipe Line Flanges"

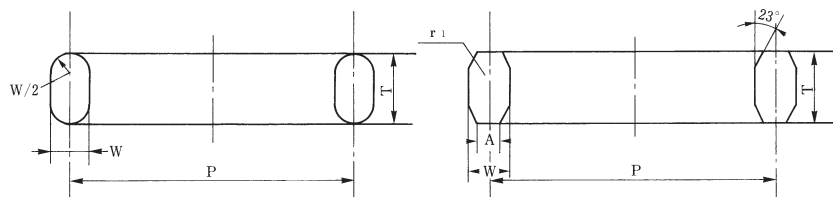

r1: When W is 22.2250mm or less: 1.59mm
When W is 25.400mm or less: 2.38mm

Oval

Octagonal

[Dimension Table 25]

Unit [mm]

Ring No.	Pitch diameter	Gasket dimensions		
		Width W	Height T	
			Oval	Octagonal
R11	34.14	6.35	11.2	9.7
R12	39.67	7.92	14.2	12.7
R13	42.88	7.92	14.2	12.7
R14	44.45	7.92	14.2	12.7
R15	47.62	7.92	14.2	12.7
R16	50.80	7.92	14.2	12.7
R17	57.15	7.92	14.2	12.7
R18	60.32	7.92	14.2	12.7
R19	65.07	7.92	14.2	12.7
R20	68.28	7.92	14.2	12.7
R21	72.24	11.13	17.5	15.7
R22	82.55	7.92	14.2	12.7
R23	82.55	11.13	17.5	15.7
R24	95.25	11.13	17.5	15.7
R25	101.60	7.92	14.2	12.7
R26	101.60	11.13	17.5	15.7
R27	107.95	11.13	17.5	15.7
R28	111.12	12.70	19.0	17.5
R29	114.30	7.92	14.2	12.7
R30	117.48	11.13	17.5	15.7
R31	123.82	11.13	17.5	15.7
R32	127.00	12.70	19.0	17.5
R33	131.78	7.92	14.2	12.7
R34	131.78	11.13	17.5	15.7
R35	136.52	11.13	17.5	15.7
R36	149.22	7.92	14.2	12.7
R37	149.22	11.13	17.5	15.7
R38	157.18	15.88	22.4	20.6
R39	161.92	11.13	17.5	15.7
R40	171.45	7.92	14.2	12.7
R41	180.98	11.13	17.5	15.7
R42	190.50	19.05	25.4	23.9
R43	193.68	7.92	14.2	12.7
R44	193.68	11.13	17.5	15.7
R45	211.12	11.13	17.5	15.7
R46	211.12	12.70	19.0	17.5
R47	228.60	19.05	25.4	23.9
R48	247.65	7.92	14.2	12.7
R49	269.88	11.13	17.5	15.7

Ring No.	Pitch diameter	Gasket dimensions		
		Width W	Height T	
			Oval	Octagonal
R50	269.88	15.88	22.4	20.6
R51	279.40	22.22	28.4	26.9
R52	304.80	7.92	14.2	12.7
R 53	323.85	11.13	17.5	15.7
R 54	323.85	15.88	22.4	20.6
R 55	342.90	28.58	36.6	35.1
R 56	381.00	7.92	14.2	12.7
R 57	381.00	11.13	17.5	15.7
R 58	381.00	22.22	28.4	26.9
R 59	396.88	7.92	14.2	12.7
R 60	406.40	31.75	39.6	38.1
R 61	419.10	11.13	17.5	15.7
R 62	419.10	15.88	22.4	20.6
R 63	419.10	25.40	33.3	31.8
R 64	454.02	7.92	14.2	12.7
R 65	469.90	11.13	17.5	15.7
R 66	469.90	15.88	22.4	20.6
R 67	469.90	28.58	36.6	35.1
R 68	517.52	7.92	14.2	12.7
R 69	533.40	11.13	17.5	15.7
R 70	533.40	19.05	25.4	23.9
R 71	533.40	28.58	36.6	35.1
R 72	558.80	7.92	14.2	12.7
R 73	584.20	12.70	19.0	17.5
R 74	584.20	19.05	25.4	23.9
R 75	584.20	31.75	39.6	38.1
R 76	673.10	7.92	14.2	12.7
R 77	692.15	15.88	22.4	20.6
R 78	692.15	25.40	33.3	31.8
R 79	692.15	34.92	44.4	41.1
R 80	615.95	7.92	—	12.7
R 81	635.00	14.27	—	19.0
R 82	57.15	11.13	—	15.7
R 84	63.50	11.13	—	15.7
R 85	79.38	12.70	—	17.5
R 86	90.47	15.88	—	20.6
R 87	100.03	15.88	—	20.6
R 88	123.82	19.05	—	23.9
R 89	114.30	19.05	—	23.9
R 90	155.58	22.22	—	26.9
R 91	260.35	31.75	—	38.1
R 92	228.60	11.13	17.5	15.7
R 93	749.30	19.05	—	23.9
R 94	800.10	19.05	—	23.9
R 95	857.25	19.05	—	23.9
R 96	914.40	22.22	—	26.9
R 97	965.20	22.22	—	26.9
R 98	1,022.35	22.22	—	26.9
R 99	234.95	11.13	—	15.7
R100	749.30	28.58	—	35.1
R101	800.10	31.75	—	38.1
R102	857.25	31.75	—	38.1
R103	914.40	31.75	—	38.1
R104	965.20	34.92	—	41.1
R105	1,022.35	34.92	—	41.1

Ring joints

■ **Applicable gaskets**

RX ring joint gaskets

■ **Applicable standard**

API Spec 6A "RX PRESSURE ENERGIZED RING-JOINT GASKETS"

■ **Applicable flange**

API Spec 6A "Wellhead Equipment 6B Flanges"

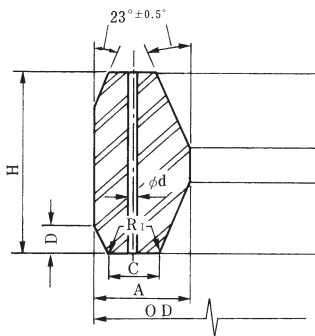

Dimensional tolerances

OD	+0.50 -0.00
A,H	+0.20 -0.00
C	+0.15 -0.00
D	+0.00 -0.80
R ₁	±0.50

[Dimension Table 26]

Unit [mm]

Ring No.	O.D. OD	Width A	Width of flat part C	Height of outer incline D	Height H	R ₁	Hole diameter φd
RX- 20	76.20	8.73	4.62	3.18	19.05	1.5	
RX- 23	93.27	11.91	6.45	4.24	25.40	1.5	
RX- 24	105.97	11.91	6.45	4.24	25.40	1.5	
RX- 25	109.54	8.73	4.62	3.18	19.05	1.5	
RX- 26	111.92	11.91	6.45	4.24	25.40	1.5	
RX- 27	118.27	11.91	6.45	4.24	25.40	1.5	
RX- 31	134.54	11.91	6.45	4.24	25.40	1.5	
RX- 35	147.24	11.91	6.45	4.24	25.40	1.5	
RX- 37	159.94	11.91	6.45	4.24	25.40	1.5	
RX- 39	172.64	11.91	6.45	4.24	25.40	1.5	
RX- 41	191.69	11.91	6.45	4.24	25.40	1.5	
RX- 44	204.39	11.91	6.45	4.24	25.40	1.5	
RX- 45	221.85	11.91	6.45	4.24	25.40	1.5	
RX- 46	222.25	13.49	6.68	4.78	28.58	1.5	
RX- 47	245.27	19.84	10.33	6.88	41.28	2.3	
RX- 49	280.59	11.91	6.45	4.24	25.40	1.5	
RX- 50	283.37	16.67	8.51	5.28	31.75	1.5	
RX- 53	334.57	11.91	6.45	4.24	25.40	1.5	
RX- 54	337.34	16.67	8.51	5.28	31.75	1.5	
RX- 57	391.72	11.91	6.45	4.24	25.40	1.5	
RX- 63	441.72	26.99	14.78	8.46	50.80	2.3	
RX- 65	480.62	11.91	6.45	4.24	25.40	1.5	
RX- 66	483.39	16.67	8.51	5.28	31.75	1.5	
RX- 69	544.12	11.91	6.45	4.24	25.40	1.5	
RX- 70	550.07	19.84	10.34	6.88	41.28	2.3	
RX- 73	596.11	13.49	6.68	5.28	31.75	1.5	
RX- 74	600.87	19.84	10.34	6.88	41.28	2.3	
RX- 82	67.87	11.91	6.45	4.24	25.40	1.5	1.5
RX- 84	74.22	11.91	6.45	4.24	25.40	1.5	1.5
RX- 85	90.09	13.49	6.68	4.24	25.40	1.5	1.5
RX- 86	103.58	15.08	8.51	4.78	28.58	1.5	1.5
RX- 87	113.11	15.08	8.51	4.78	28.58	1.5	1.5
RX- 88	139.30	17.46	10.34	5.28	31.75	1.5	3.0
RX- 89	129.78	18.26	10.34	5.28	31.75	1.5	3.0
RX- 90	174.63	19.84	12.17	7.42	44.45	2.3	3.0
RX- 91	286.94	30.16	19.81	7.54	45.24	2.3	3.0
RX- 99	245.67	11.91	6.45	4.24	25.40	1.5 ⁽²⁾	
RX-201	51.46	5.74	3.20	1.45	11.30	0.5 ⁽²⁾	
RX-205	62.31	5.56	3.05	1.83 ⁽¹⁾	11.10	0.5 ⁽²⁾	
RX-210	97.63	9.53	5.41	3.18 ⁽¹⁾	19.05	0.8 ⁽²⁾	
RX-215	140.89	11.91	5.33	4.24 ⁽¹⁾	25.40	1.5 ⁽²⁾	

Note: (1) Dimensional tolerance +0, -0.38 (2) Dimensional tolerance +0.5, -0

*From RX-82 to RX-91, there is a pressure relief hole in the ring.

*The finish of the gasket sealing face must be at least 63RMS.

Ring joints

■ **Applicable gaskets**

BX type ring joint gaskets

■ **Applicable standard**

API Spec 6A-1977 BX
"PRESSURE ENERGIZED RINGJOINTGASKETS"

■ **Applicable flange**

API Spec 6A
"Wellhead Equipment 6BX Flanges"

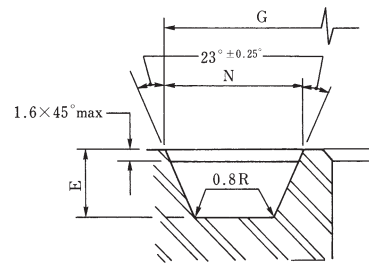
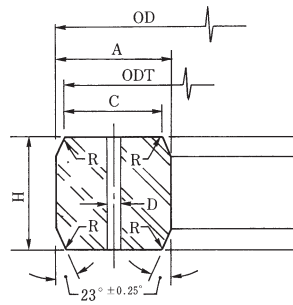

Dimensional tolerances

OD	+0.0 -0.15
H,A	+0.20 -0
ODT	±0.05
C	+0.15 -0
E	+0.50 -0
G,N	+0.10 -0.0

[Dimension Table 27]

Unit [mm]

Ring No.	Gasket dimensions							Groove dimensions		
	O.D. OD	Height H	Width A	O.D. of flat part ODT	Width of flat part C	Hole diameter ϕd	R	Depth E	O.D. G	Width N
BX-150	72.19	9.30	9.30	70.87	7.98	1.59	8 - 12% of gasket height H	5.56	73.48	11.43
BX-151	76.40	9.63	9.63	75.03	8.26	1.59		5.56	77.79	11.84
BX-152	84.68	10.24	10.24	83.24	8.79	1.59		5.95	86.23	12.65
BX-153	100.94	11.38	11.38	99.31	9.78	1.59		6.75	102.77	14.07
BX-154	116.84	12.40	12.40	115.09	10.64	1.59		7.54	119.00	15.39
BX-155	147.96	14.22	14.22	145.95	12.22	1.59		8.33	150.62	17.73
BX-169	173.51	15.85	12.93	171.27	10.69	1.59		9.53	176.66	16.92
BX-156	237.92	18.62	18.62	235.28	15.98	3.18		11.11	241.83	23.39
BX-157	294.46	20.98	20.98	291.49	18.01	3.18		12.70	299.06	26.39
BX-158	352.04	23.14	23.14	348.77	19.86	3.18		14.29	357.23	29.18
BX-159	426.72	25.70	25.70	423.09	22.07	3.18		15.88	432.64	32.49
BX-160	402.59	23.83	13.74	399.21	10.36	3.18		14.29	408.00	19.96
BX-161	491.41	28.07	16.21	487.45	12.24	3.18		17.07	497.94	23.62
BX-162	475.49	14.22	14.22	473.48	12.22	1.59		8.33	478.33	17.91
BX-163	556.16	30.10	17.37	551.89	13.11	3.18		18.26	563.50	25.55
BX-164	570.56	30.10	24.59	566.29	20.32	3.18		18.26	577.90	32.77
BX-165	624.71	32.03	18.49	620.19	13.97	3.18		19.05	632.56	27.20
BX-166	640.03	32.03	26.14	635.51	21.62	3.18		19.05	647.88	34.87
BX-167	759.36	35.87	13.11	754.28	8.03	1.59	21.43	768.33	22.91	
BX-168	765.25	35.87	16.05	760.17	10.97	1.59	21.43	774.22	25.86	

*There is one pressure relief hole on the centerline of the gasket.
*The finish of the gasket sealing face must be at least 32RMS.

Ring No., nominal flange diameter and nominal pressure

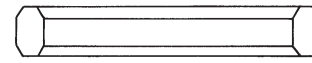
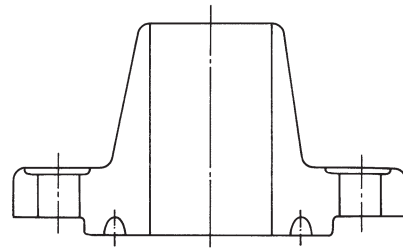

Octagonal type

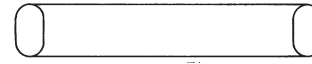

Oval type

TOMBO™ No.1850-C
TOMBO™ No.1850-V

[Dimension Table 28]

Unit [mm]

Nominal flange diameter	Applicable flange										
	JPI-7S-15, ASME B 16.5					API Spec 6A				MSS SP-44	
	Class 150	300, 400 600	900	1500	2500	960	2000	3000	5000	300, 400 600	900
1/2 B	—	R11	R12	R12	R13	—	—	—	—	—	—
3/4	—	R13	R14	R14	R16	—	—	—	—	—	—
1	R15	R16	R16	R16	R18	—	—	—	—	—	—
1 1/4	R17	R18	R18	R18	R21	—	—	—	—	—	—
1 1/2	R19	R20	R20	R20	R23	—	R20	R20	R20	—	—
2	R22	R23	R24	R24	R26	—	R23	R24	R24	—	—
2 1/2	R25	R26	R27	R27	R28	—	R26	R27	R27	—	—
3	R29	R30 ⁽¹⁾ R31	R31	R35	R32	—	R31	R31	R35	—	—
3 1/2	R33	R34	—	—	—	—	—	—	—	—	—
4	R36	R37	R37	R39	R38	—	R37	R37	R39	—	—
5	R40	R41	R41	R44	R42	—	R41	R41	—	—	—
6	R43	R45	R45	R46	R47	R45	R45	R45	R46	—	—
8	R48	R49	R49	R50	R51	R49	R49	R49	R50	—	—
10	R52	R53	R53	R54	R55	R53	R53	R53	R54	—	—
12	R56	R57	R57	R58	R60	R57	R57	R57	—	R57	R57
14	R59	R61	R62	R63	—	—	—	—	R63	R61	R62
16	R64	R65	R66	R67	—	R65	R65	R66	—	R65	R66
18	R68	R69	R70	R71	—	—	R69	R70	—	R69	R70
20	R72	R73	R74	R75	—	R73	R73	R74	—	R73	R74
22	—	—	—	—	—	—	—	—	—	R81	—
24	R76	R77	R78	R79	—	—	—	—	—	R77	R78
26	—	R93	R100	—	—	—	—	—	—	R93	R100
28	—	R94	R101	—	—	—	—	—	—	R94	R101
30	—	R95	R102	—	—	—	—	—	—	R95	R102
32	—	R96	R103	—	—	—	—	—	—	R96	R103
34	—	R97	R104	—	—	—	—	—	—	R97	R104
36	—	R98	R105	—	—	—	—	—	—	R98	R105

Note: (1) R30 applies only to a lapped joint.

*For the same groove (same R No.), either an oval type or an octagonal may be used.

NAFLON™ PTFE envelope gaskets (TOMBO™ No.9010-A/B)

■ Applicable gaskets
NAFLON™ PTFE envelope gaskets
"TOMBO™ No.9010-A, 9010-B"

■ Applicable flanges
JIS B 2220-2012 "Steel Pipe Flanges"
(Old) JIS B 2238-1996 "General Rules for Steel Pipe Flanges"

*This dimension table has been prepared by Nichias based on (Old) JIS B 2238-1996.

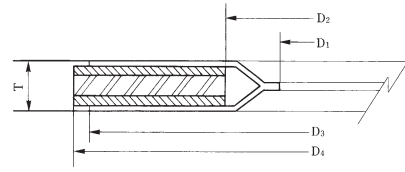

Type A-6, type A-8

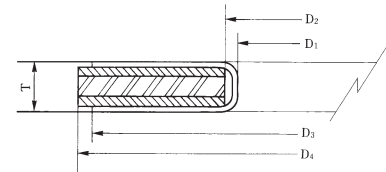

Type B-6, type B-8

[Dimension Table 29]

Unit [mm]

Nominal flange diameter		D ₁	D ₂	5K		10K (standard)		16K		20K		T	Type No.
A	B			D ₃	D ₄	D ₃	D ₄	D ₃	D ₄	D ₃	D ₄		
10	3/8	18	26	42	45	49	53	48	53	49	53	3.2 (2.8)	Type A
15	1/2	22	30	46	50	54	58	52	58	54	58		
20	3/4	28	36	52	55	59	63	58	63	59	63		
25	1	35	43	59	65	70	74	70	74	70	74		
32	1 1/4	43	51	71	78	79	84	79	84	79	84		
40	1 1/2	49	57	77	83	85	89	85	89	85	89		
50	2	62	69	88	93	99	104	100	104	99	104		
65	2 1/2	78	85	106	118	119	124	116	124	119	124		
80	3	91	98	121	129	129	134	135	140	135	140		
90	3 1/2	104	111	134	139	140	144	145	150	148	150		
100	4	117	124	145	149	155	159	160	165	163	165		
125	5	144	151	178	184	185	190	195	203	198	203		
150	6	171	178	205	214	215	220	227	238	233	238		
175	7	193	200	229	240	240	245	—	—	—	—		
200	8	219	226	255	260	265	270	275	283	278	283		
225	9	244	251	280	285	285	290	—	—	—	—		
250	10	271	278	313	325	321	333	345	356	345	356		
300	12	321	328	363	370	370	378	395	406	395	406		
350	14	356	363	401	413	415	423	436	450	436	450		
400	16	407	414	461	473	471	486	487	510	487	510		
450	18	457	464	511	533	530	541	556	575	556	575		
500	20	510	517	571	583	583	596	609	630	609	630		
550	22	561	568	625	641	635	650	665	684	665	684		
600	24	612	619	676	691	684	700	716	734	716	734		
650	26	670	674	735	746	740	750	770	784	790	805		
700	28	725	729	785	796	800	810	820	836	840	855		
750	30	775	779	840	850	855	870	880	896	900	918		
800	32	825	829	890	900	905	920	930	945	960	978		
850	34	875	879	940	950	955	970	980	995	1,020	1,038		
900	36	925	929	990	1,000	1,005	1,020	1,030	1,045	1,070	1,088		
1,000	40	1,030	1,034	1,090	1,100	1,110	1,124	1,140	1,158	—	—	3.2 (3.8)	Type B
1,100	44	1,130	1,134	1,200	1,210	1,220	1,234	1,240	1,258	—	—		
1,200	48	1,230	1,234	1,305	1,320	1,325	1,344	1,350	1,368	—	—		
1,300	52	1,335	1,339	—	—	—	—	1,450	1,474	—	—		
1,350	54	1,390	1,394	1,460	1,475	1,480	1,498	1,510	1,534	—	—		
1,400	56	1,435	1,439	—	—	—	—	1,560	1,584	—	—		
1,500	60	1,545	1,549	1,615	1,630	1,635	1,658	1,670	1,694	—	—		

*Dimensions in parentheses () are applicable to TOMBO™ No.9010-A-5 and 9010-A-7, and also to 9010-B-5 and 9010-B-7.

*Inside bold border □ : Cannot be used for type B nominal diameter 10 - 50A of JIS B 2220 nominal pressure 20K slip-on welded flanges.

For JPI pipe flanges

NAFLON™ PTFE envelope gaskets (TOMBO™ No.9010-A/B)

■ **Applicable gaskets**
 NAFLON™ PTFE envelope gaskets
 "TOMBO™ No.9010-A, 9010-B"

■ **Applicable standards**
 JPI-7S-15-1999 (Class 150, 24B or lower)
 "Forged Steel Flanges for the Petroleum Industry"
 JPI-7S-43-2001 (Class 300, 26B or higher)
 "Large Bore Flanges for the Petroleum Industry"

■ **Applicable flanges**
 JPI-15 "Forged Steel Flanges for the Petroleum Industry"
 JPI-7S-43 "Large Bore Flanges for the Petroleum Industry"
 ASME B16.5 "Pipe Flanges and Flanged Fittings"
 ANSI B 16.5 "Steel pipe Flange"
 API-Std 605 "Standard for Large-Diameter Carbon Steel Flanges"

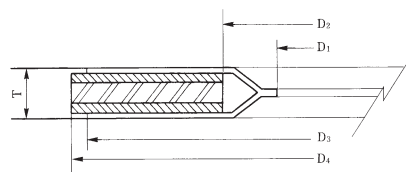

Type A-6, type A-8

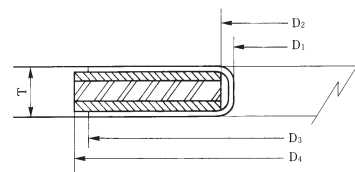

Type B-6, type B-8

*The dimensions for class 150, 24B or lower are the same as JPI-7S-75-2013. The dimensions for 26B or higher and class 300 have been prepared by Nichias based on JPI-7S-43-2001.

[Dimension Table 30]

Unit [mm]

Nominal flange diameter	D ₁	D ₂	Class 75		Class 150		Class 300		T	Type No.
			D ₃	D ₄	D ₃	D ₄	D ₃	D ₄		
1/2 B	17	24	—	—	47	47	47	53	3.2 (2.8)	Type A
3/4	22	29	—	—	56	56	56	66		
1	28	35	—	—	66	66	66	72		
1 1/4	36	43	—	—	75	75	75	82		
1 1/2	42	49	—	—	85	85	85	94		
2	53	60	—	—	92	104	92	110		
2 1/2	66	73	—	—	105	123	105	129		
3	90	97	—	—	127	135	127	148		
3 1/2	103	110	—	—	140	161	140	164		
4	116	123	—	—	157	173	157	180		
5	143	150	—	—	186	196	186	215		
6	169	176	—	—	216	221	216	250		
8	220	227	—	—	270	277	270	306		
10	275	282	—	—	324	338	324	360		
12	326	333	—	—	381	408	381	420		
14	358	365	—	—	413	449	413	484		
16	408	415	—	—	470	512	470	538		
18	459	466	—	—	533	547	533	595		
20	510	517	—	—	584	604	584	651		
24	612	619	—	—	692	715	692	772		
26	673	677	705	705	711	722	737	769		
28	724	728	756	756	762	773	787	822		
30	775	779	806	807	813	824	845	883		
32	826	830	857	857	864	878	902	937		
34	876	880	908	908	921	932	952	991		
36	927	931	965	970	972	984	1,010	1,045		
38	978	982	1,016	1,021	1,022	1,042	1,060	1,096		
40	1,029	1,033	1,067	1,072	1,080	1,092	1,118	1,146		
42	1,080	1,084	1,118	1,123	1,130	1,143	1,168	1,197		
44	1,130	1,134	1,168	1,178	1,187	1,194	1,219	1,248		
46	1,181	1,185	1,226	1,229	1,238	1,253	1,276	1,315		
48	1,232	1,236	1,276	1,280	1,289	1,304	1,327	1,365		
54	1,384	1,388	1,429	1,435	1,441	1,461	1,480	1,527		
60	1,537	1,541	1,588	1,594	1,600	1,625	1,651	1,702		

*Dimensions in parentheses () are applicable to TOMBO™ No.9010-A-5 and 9010-A-7, and also to 9010-B-5 and 9010-B-7.

*Inside bold border □: These cannot be used for a JPI-7S-15 slip-on type flange that has a nominal diameter of 2 1/2 B (65A) or less because the gasket I.D. (D1) is inward of the flange I.D.

NAFLON™ PTFE envelope gaskets (TOMBO™ No.9010-B)

■ Applicable gaskets

NAFLON™ PTFE envelope gasket "TOMBO™ No.9010-B"

■ Applicable flanges

ASME/ANSI B 16.1 "Cast Iron Pipe Flanges and Flanged Fittings"
TAYLOR FORGE flange (Values marked ☆ in the dimension table are applicable to a TAYLOR FORGE flange.)

*This dimension table has been prepared by Nichias based on the above applicable flange.

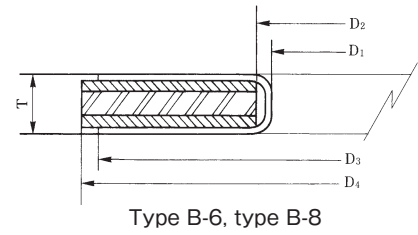

[Dimension Table 31]

Unit [mm]

Nominal flange diameter		D ₁	D ₂	Class 125		Class 250		T	Type No.
A	B			D ₃	D ₄	D ₃	D ₄		
650	26☆	673	677	767	775	824	832	3.2 (3.8)	Type B
700	28☆	724	728	824	832	887	895		
750	30	775	779	875	883	945	952		
800	32☆	826	830	932	940	1,002	1,010		
850	34☆	876	880	983	991	1,053	1,060		
900	36	927	931	1,040	1,048	1,110	1,118		
950	38☆	978	982	1,103	1,111	1,160	1,168	5.0 (3.8)	
1,000	40☆	1,029	1,033	1,154	1,162	1,218	1,226		
1,050	42	1,080	1,084	1,211	1,219	1,281	1,289		
1,100	44☆	1,130	1,134	1,268	1,276	1,338	1,346		
1,150	46☆	1,181	1,185	1,319	1,327	1,395	1,403		
1,200	48	1,232	1,236	1,376	1,384	1,484	1,492		
1,250	50☆	1,283	1,287	1,427	1,435	—	—		
1,300	52☆	1,334	1,338	1,484	1,492	—	—		
1,350	54	1,384	1,388	1,541	1,549	—	—		
1,500	60	1,537	1,541	1,707	1,714	—	—		
1,650	66☆	1,689	1,693	1,878	1,886	—	—		
1,800	72	1,842	1,846	2,043	2,051	—	—		
2,100	84	2,146	2,150	2,367	2,375	—	—		
2,400	96	2,451	2,455	2,691	2,699	—	—		

*Dimensions in parentheses () are applicable to TOMBO™ No.9010-B-5 and 9010-B-7.

For MSS pipe flanges

NAFLON™ PTFE envelope gaskets (TOMBO™ No.9010-B)

■ Applicable gaskets

NAFLON™ PTFE envelope gaskets "TOMBO™ No.9010-B"

■ Applicable flanges

MSS SP-44 "Steel Pipe Line Flanges"

*This dimension table has been prepared by Nichias based on MSS SP-44-1996.

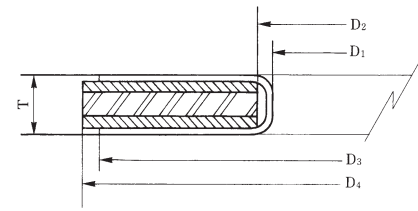

Type B-6, type B-8

[Dimension Table 32]

Unit [mm]

Nominal flange diameter		D ₁	D ₂	Class 150		Class 300		T	Type No.
A	B			D ₃	D ₄	D ₃	D ₄		
650	26	673	677	749	775	749	835	3.2 (3.8)	Type B
700	28	724	728	800	832	800	899		
750	30	775	779	857	883	857	952		
800	32	826	830	914	940	914	1,006		
850	34	876	880	965	991	965	1,057		
900	36	927	931	1,022	1,048	1,022	1,118		
950	38	978	982	1,073	1,111	1,029	1,054	5.0 (3.8)	
1,000	40	1,029	1,033	1,124	1,162	1,086	1,114		
1,050	42	1,080	1,084	1,194	1,219	1,137	1,165		
1,100	44	1,130	1,134	1,245	1,276	1,194	1,219		
1,150	46	1,181	1,185	1,295	1,327	1,245	1,273		
1,200	48	1,232	1,236	1,359	1,384	1,302	1,324		
1,250	50	1,283	1,287	1,410	1,435	1,359	1,378		
1,300	52	1,334	1,338	1,460	1,492	1,410	1,429		
1,350	54	1,384	1,388	1,511	1,549	1,467	1,492		
1,400	56	1,435	1,439	1,575	1,607	1,518	1,543		
1,450	58	1,486	1,490	1,626	1,664	1,575	1,594		
1,500	60	1,537	1,541	1,676	1,714	1,626	1,645		

*Dimensions in parentheses () are applicable to TOMBO™ No.9010-B-5 and 9010-B-7.

NAFLON™ PTFE envelope gaskets (TOMBO™ No.9010-AS)

- Applicable gaskets
NAFLON™ PTFE envelope gaskets "TOMBO™ No.9010-AS"
- Applicable flanges
JIS B 2220-2012 "Steel Pipe Flanges"
(Old) JIS B 2238-1996 "General Rules for Steel Pipe Flanges"

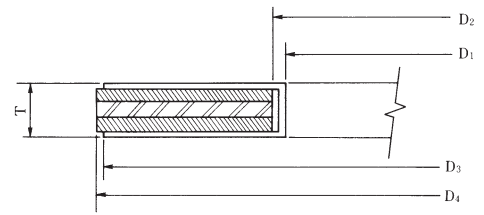

Type AS-6, type AS-8

[Dimension Table 33]

Unit [mm]

Nominal flange diameter		D ₁	D ₂	5K		10K (standard)		16K, 20K		T	Type No.
A	B			D ₃	D ₄	D ₃	D ₄	D ₃	D ₄		
10	3/8	26	28	42	45	48	53	48	53	2.5 (2.5)	Type AS
15	1/2	31	33	48	50	52	58	52	58		
20	3/4	36	38	52	55	58	63	58	63		
25	1	41	43	62	65	70	74	70	74		
32	1 1/4	51	53	72	78	80	84	80	84		
40	1 1/2	56	58	78	83	85	89	85	89		
50	2	67	70	88	93	100	104	100	104	3.4 (3.0)	
65	2 1/2	92	95	112	118	120	124	120	124		
80	3	102	105	125	129	130	134	135	140		
90	3 1/2	112	115	135	139	140	144	145	150		
100	4	122	125	145	149	155	159	160	165		
125	5	152	155	180	184	185	190	195	203		
150	6	187	190	210	214	215	220	230	238		
175	7	207	210	235	240	240	245	—	—		
200	8	232	235	255	260	265	270	275	283		
225	9	257	260	280	285	285	290	—	—		
250	10	297	300	320	325	325	333	345	356		
300	12	337	340	365	370	370	378	395	406		
350	14	377	380	405	413	415	423	440	450		
400	16	427	430	465	473	475	486	495	510		
450	18	477	480	525	533	530	541	560	575		
500	20	527	530	575	583	585	596	615	630		
550	22	577	580	630	641	640	650	670	684		
600	24	627	630	680	691	690	700	720	734		

*This gasket cannot be used for type B, nominal diameter 10 - 50A of JIS B 2220, nominal pressure 20K, slip-on welded flanges because the gasket I.D. (D1) is inward of the flange I.D.

*Dimensions in parentheses () are applicable to TOMBO™ No.9010-AS-5 and 9010-AS-7.

For JPI pipes flanges

NAFLON™ PTFE envelope gaskets (TOMBO™ No.9010-AS)

■ **Applicable gaskets**

NAFLON™ PTFE envelope gasket "TOMBO™ No.9010-AS"

■ **Applicable flanges**

JPI-7S-15 "Forged Steel Flanges for the Petroleum Industry"
 API-Std 605 "Standard for Large-Diameter Carbon Steel Flanges"
 ASME B16.5 "Pipe Flanges and Flanged Fittings"
 ANSI B 16.5 "Steel pipe Flange"

*This dimension has been prepared by Nichias based on JPI 7S-15-1999.

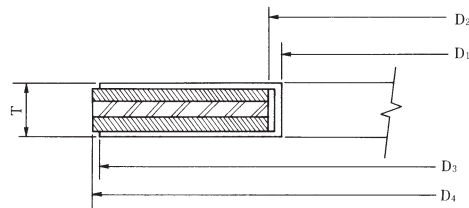

Type AS-6, type AS-8

[Dimension Table 34]

Unit [mm]

Nominal flange diameter		D ₁	D ₂	Class 150			Class 300			Type No.
A	B			D ₃	D ₄	T	D ₃	D ₄	T	
15	1/2	21	24	47	47	2.5 (2.8)	36	53	2.5 (2.5)	Type AS
20	3/4	26	29	56	56		44	66		
25	1	32	35	66	66		52	72		
32	1 1/4	40	43	75	75		65	82		
40	1 1/2	46	49	85	85		74	94		
50	2	57	60	92	104		92	110		
65	2 1/2	70	73	105	123	105	129	3.4 (3.0)		
80	3	94	97	127	135	127	148			
90	3 1/2	107	110	140	161	140	164			
100	4	120	123	157	173	157	180			
125	5	147	150	186	196	186	215			
150	6	173	176	216	221	216	250			
200	8	224	227	270	277	270	306	3.4 (3.0)		
250	10	279	282	324	338	324	360			
300	12	330	333	381	408	381	420			
350	14	362	365	413	449	413	484			
400	16	412	415	470	512	470	538			
450	18	463	466	533	547	533	595			
500	20	514	517	584	604	584	651	3.4 (3.0)		
600	24	616	619	692	715	692	772			

*Dimensions in parentheses () are applicable to TOMBO™ No.9010-AS-5 and 9010-AS-7.

*Inside bold border □: These cannot be used for a JPI-7S-15 slip-on type flange that has a nominal diameter of 2 1/2 B (65A) or less because the gasket I.D. (D1) is inward of the flange I.D.

NAFLON™ PTFE envelope gaskets (TOMBO™ No.9010-FG-7)

■ **Applicable gaskets**

NAFLON™ PTFE envelope gasket "TOMBO™ No.9010-FG-7"

■ **Applicable flanges**

For fluoro-piping JIS standard dimension 10K and ASME (JPI) Class 150

*TOMBO™ No.9010-FG-7 is a PTFE jacketed gasket which is used in our corrosion resistant fluoro-piping.

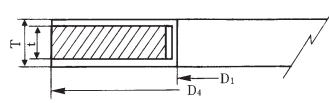

Type AS-7

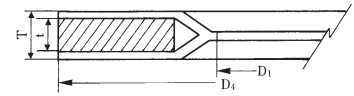

Type A-7

[Dimension Table 35]

Unit [mm]

Nominal flange diameter		For JIS 10K				For ANSI (JPI) Class 150				Type No.
A	B	D ₁	D ₄	t	T	D ₁	D ₄	t	T	
15	1/2	16	58	1.5	2.3	16	47	1.5	2.3	Type AS-7
20	3/4	22	63			22	56			
25	1	27	74			28	66			
40	1 1/2	45	89			45	85			
50	2	58	104			58	104			
65	2 1/2	71	124			71	123			
80	3	85	134			85	135			Type A-7
100	4	104	159			110	173			
125	5	128	189			128	196			
150	6	153	220			160	221			
200	8	202	270			214	277			
250	10	251	333			266	338			
300	12	300	378			328	408			

If a solid gasket is desired, use NAFLON™ PTFE cut gaskets (TOMBO™ No.9007) or NAFLON™ PTFE Low Creep gaskets (TOMBO™ No.9007-LC) shown in the figure below. D₁, D₄ and t are based on the Dimension table 35.

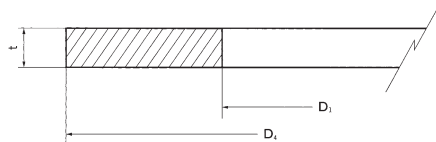

NAFLON™ PTFE cut gasket (TOMBO™ No.9007)

NAFLON™ PTFE Low Creep gasket (TOMBO™ No.9007-LC)

For glass-lined flange (JIS dimensions)

NAFLON™ PTFE envelope gaskets (TOMBO™ No.9010-GL-5, 6, 7 and 8 [Type A])

■ Applicable gaskets

NAFLON™ PTFE envelope gasket (TOMBO™ No.9010-A-5, 6, 7, 8)

■ Applicable flange

GL flange (AGC TECHNOLOGY SOLUTIONS CO., LTD.)

*This dimension table has been prepared by Nichias based on the dimensions of the above flange.

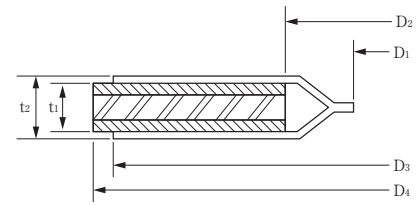

[Dimension Table 36]

Unit [mm]

Nominal flange diameter	D ₁	D ₂	D ₃	D ₄	t ₁	t ₂
A						
20	19	29	61	63	2.0 (2.4)	2.8 (3.2)
25	25	35	72	74		
40	38	48	87	89		
50	50	60	102	104		
65	65	75	122	124		
80	77	87	132	134		
100	103	113	157	159		
150	153	163	219	220		
200	201	211	269	270		

*The dimensions of glass-lined flanges differ from one manufacturer to another, so please consult us before using a non-applicable flange.

*The values in parentheses () apply to TOMBO™ No.9010-GL-6, 8.

*The standard setting of the core of AGC TECHNOLOGY SOLUTIONS is TOMBO™ No.9010-GL-5, 7.

NAFLON™ PTFE envelope gaskets (TOMBO™ No.9010-GL-5, 6, 7 and 8 [Type A])

■ **Applicable gaskets**

NAFLON™ PTFE envelope gaskets (TOMBO™ No.9010-A-5, 6, 7 and 8)

■ **Applicable flange**

GL flange (AGC TECHNOLOGY SOLUTIONS CO., LTD.)

*This dimension table has been prepared by Nichias based on the dimensions of the above flange.

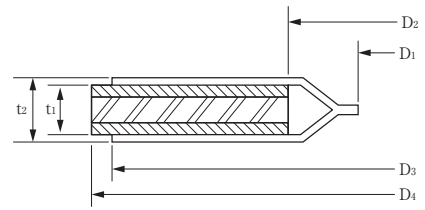

[Dimension Table 37]

Unit [mm]

Nominal diameter		D ₁	D ₂	D ₃	D ₄	t ₁	t ₂
A	B						
20	¾	19	29	56	58	2.0 (2.4)	2.8 (3.2)
25	1	25	35	65	67.5		
40	1 ½	38	48	84	86.5		
50	2	50	60	102	104.5		
65	2 ½	65	75	122	123.5		
80	3	77	87	134	136.5		
100	4	103	113	172	174.5		
150	6	153	163	220	221.5		
200	8	201	211	276	278.5		

*The dimensions of glass-lined flanges differ from one manufacturer to another, so please consult us if you intend to use a non-applicable flange.

*The values in parentheses () apply to TOMBO™ No.9010-GL-6, 8.

*The standard setting of the core of AGC TECHNOLOGY SOLUTIONS is TOMBO™ No.9010-GL-5, 7.

For JIS pipe flanges

NAFLON™ PTFE envelope gaskets [Fully-covered] (TOMBO™ No.9010-RA)

■ **Applicable gaskets**

NAFLON™ PTFE envelope gaskets [Fully-covered]
"TOMBO™ No.9010-RA"

■ **Applicable standard ⁽¹⁾**

(Old) JIS B 2238-1996

■ **Applicable flanges**

JIS B 2220-2012 "Steel Pipe Flanges"

(Old) JIS B 2238-1996 "General Rules for Steel Pipe Flanges"

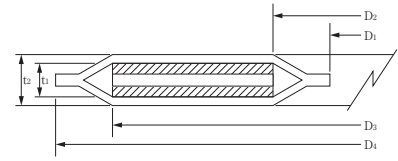

Note: (1) This dimension table has been prepared by Nichias based on (Old) JIS B 2238-1996.

[Dimension Table 38]

Unit [mm]

Nominal flange diameter A	D ₁	D ₂	D ₃		D ₄		t ₁	t ₂
			Nominal pressure K		Nominal pressure K			
			5	10	5	10		
10	13	20	33	41	45	53	2.0 (2.4)	2.8 (3.2)
15	17	24	38	46	50	58		
20	22	29	43	51	55	63		
25	28	35	53	62	65	74		
32	36	43	66	72	78	84		
40	42	49	71	77	83	89		
50	53	60	81	92	93	104		
65	66	73	106	112	118	124		
80	79	86	117	122	129	134		
90	91	98	127	132	139	144		
100	103	110	137	147	149	159		
125	135	142	172	178	184	190		
150	162	169	202	208	214	220		
175	184	191	228	233	240	245		
200	210	217	248	258	260	270		
225	236	243	273	278	285	290		
250	270	277	313	321	325	333		
300	316	323	358	366	370	378		
350	351	358	401	411	413	423		
400	410	417	461	474	473	486		
450	455	462	521	529	533	541		
500	511	518	571	584	583	596		
550	564	571	629	638	641	650		
600	616	623	679	688	691	700		

*Dimensions in parentheses () are applicable to TOMBO™ No.9010-R-A-6 and 9010-R-A-8.

NAFLON™ PTFE envelope gaskets [Fully-covered] (TOMBO™ No.9010-RS)

■ **Applicable gaskets**

NAFLON™ PTFE envelope gaskets [Fully-covered]
"TOMBO™ No.9010-RS"

■ **Applicable standard** ⁽¹⁾

(Old) JIS B 2238-1996

■ **Applicable flanges**

JIS B 2220-2012 "Steel Pipe Flanges"

(Old) JIS B 2238-1996 "General Rules for Steel Pipe Flanges"

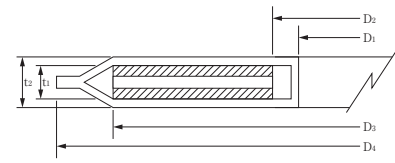

Note: (1) This dimension table has been prepared by Nichias based on (Old) JIS B 2238-1996.

[Dimension Table 39]

Unit [mm]

Nominal flange diameter	D ₁	D ₂	D ₃		D ₄		t ₁	t ₂
			Nominal pressure K		Nominal pressure K			
			5	10	5	10		
A								
10	13	16	33	41	45	53	2.0 (2.4)	3.0 (3.4)
15	17	20	38	46	50	58		
20	22	25	43	51	55	63		
25	28	31	53	62	65	74		
32	36	39	66	72	78	84		
40	42	45	71	77	83	89		
50	53	56	81	92	93	104		
65	66	69	106	112	118	124		
80	79	82	117	122	129	134		
90	91	94	127	132	139	144		
100	103	106	137	147	149	159		
125	143	146	172	178	184	190		
150	179	182	202	208	214	220		
175	198	201	228	233	240	245		
200	224	227	248	258	260	270		
225	249	252	273	278	285	290		
250	292	295	313	321	325	333		
300	332	335	358	366	370	378		
350	372	375	401	411	413	423		
400	425	428	461	474	473	486		
450	475	478	521	529	533	541		
500	525	528	571	584	583	596		
550	574	577	629	638	641	650		
600	624	627	679	688	691	700		

*Dimensions in parentheses () are applicable to TOMBO™ No.9010-AS-6 and 9010-AS-8.

For JIS pipe flanges

NAFLON™ PTFE envelope gasket [High-temperature type] (TOMBO™ No.9010-A-9)

■ Applicable gaskets

NAFLON™ PTFE envelope gaskets [high-temperature type]
"TOMBO™ No.9010-A-9"

■ Applicable standard ⁽¹⁾

(Old) JIS B 2238-1996

■ Applicable flanges

JIS B 2220-2012 "Steel Pipe Flanges"

(Old) JIS B 2238-1996 "General Rules for Steel Pipe Flanges"

Note: (1) This dimension table has been prepared by Nichias based on (Old) JIS B 2238-1996.

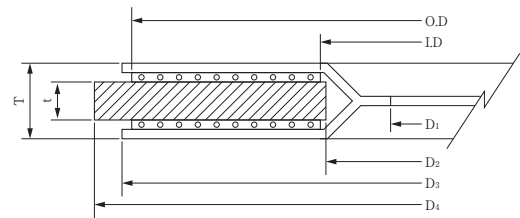

Type A

[Dimension Table 40]

Unit [mm]

Nominal flange diameter		D ₁	D ₂	10K (standard)				16, 20K				t	T	Shape
				D ₃	D ₄	Mesh		D ₃	D ₄	Mesh				
A	B	I.D	O.D			I.D	O.D							
(10)	$\frac{3}{8}$	18	26	49	53	30	47	49	53	30	47	2.0	3.9	Type A
(15)	$\frac{1}{2}$	22	30	54	58	34	52	54	58	34	52			
(20)	$\frac{3}{4}$	28	36	59	63	40	57	59	63	40	57			
25	1	35	43	70	74	47	68	70	74	47	68			
32	1 $\frac{1}{4}$	43	51	79	84	55	77	79	84	55	77			
40	1 $\frac{1}{2}$	49	57	85	89	61	83	85	89	61	83			
50	2	61	69	99	104	73	97	99	104	73	97			
65	2 $\frac{1}{2}$	77	85	119	124	89	117	119	124	89	117			
80	3	90	98	129	134	102	127	135	140	102	133			
90	3 $\frac{1}{2}$	103	111	140	144	115	138	148	150	115	146			
100	4	116	124	155	159	128	153	163	165	128	161			
125	5	143	151	185	190	155	183	198	203	155	196			
150	6	170	178	215	220	182	213	233	238	182	231			
175	7	192	200	240	245	204	238	—	—	204	—			
200	8	218	226	265	270	230	263	278	283	230	276			
225	9	243	251	285	290	255	283	—	—	255	—			
250	10	270	278	321	333	282	319	345	356	282	343			
300	12	320	328	370	378	332	368	395	406	332	393			
350	14	355	363	415	423	367	413	436	450	367	434			
400	16	406	414	471	486	418	469	487	510	418	485			
450	18	456	464	530	541	468	528	556	575	468	554			
500	20	509	517	583	596	521	581	609	630	521	607			
550	22	560	568	635	650	572	633	665	684	572	663			
600	24	611	619	684	700	623	682	716	734	623	714			

*This gasket cannot be used for JIS B 2220, nominal pressure 20K, slip-on welded flanges at a nominal pressure of 10K, 16K and 20K, a nominal diameter of 10A - 40A, or a nominal pressure of 20K because the gasket I.D. (D1) is inward of the flange I.D.

NAFLON™ PTFE envelope gaskets [High-temperature type] (TOMBO™ No.9010-A-9)

■ **Applicable gaskets**

NAFLON™ PTFE envelope gaskets [High-temperature type]
"TOMBO™ No.9010-A-9"

■ **Applicable flange**

JPI-7S-15 "Forged Steel Flanges for the Petroleum Industry"
API-Std 605 "Standard for Large-Diameter Carbon Steel Flanges"
ASME B16.5 "Pipe Flanges and Flanged Fittings"
ANSI B 16.5 "Steel pipe Flange"

*This dimension table has been prepared by Nichias based on JPI-7S-15-1999.

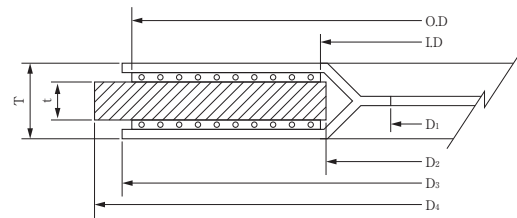

Type A

[Dimension Table 41]

Unit [mm]

Nominal flange diameter		D ₁	D ₂	Class 150				Class 300				t	T	Shape
				D ₃	D ₄	Mesh		D ₃	D ₄	Mesh				
A	B	I.D	O.D			I.D	O.D							
15	1/2	17	25	47	47	26	36	47	53	26	36	2.0	3.9	Type A
20	3/4	22	30	56	56	31	42	56	66	31	42			
25	1	28	36	66	66	38	50	66	72	38	50			
32	1 1/4	36	44	75	75	49	63	75	82	49	63			
40	1 1/2	42	50	85	85	55	72	85	94	55	72			
50	2	53	61	92	104	70	90	92	110	70	90			
65	2 1/2	66	74	105	123	83	103	105	129	83	103			
80	3	90	98	127	135	105	125	127	148	105	125			
90	3 1/2	103	111	140	161	118	138	140	164	118	138			
100	4	116	124	157	173	136	155	157	180	136	155			
125	5	143	151	186	196	164	184	186	215	164	184			
150	6	169	177	216	221	194	214	216	250	194	214			
200	8	220	228	270	277	242	268	270	306	242	268			
250	10	275	283	324	338	290	322	324	360	290	322			
300	12	326	334	381	408	347	379	381	420	347	379			
350	14	358	365	413	449	377	411	413	484	377	411			
400	16	408	416	470	512	432	468	470	538	432	468			
450	18	459	467	533	547	487	531	533	595	487	531			
500	20	510	518	584	604	537	582	584	651	537	582			
600	24	612	620	692	715	637	690	692	772	637	690			

*This gasket cannot be used for JPI-7S-15 slip-on type flange that has a nominal diameter of 2 1/2B (65A) or less because the gasket I.D. (D1) is inward of the flange I.D.

Plastic flanges

For 10K

■ Applicable gaskets

EBILON™ gasket [covered with PTFE] "TOMBO™ No.9013, 9013-D"

EBILON™ gasket [uncovered rubber] "TOMBO™ No.9013-EP, 9013-DEP"

■ Applicable flanges

Plastic 10K flanges

(PVC flanges made by Kubota, Sekisui Chemical, AOC)

*The dimensions of these gaskets have been set by Nichias according to the I.D. of the plastic flanges, based on JIS B 2210 "Reference Dimensions of Cast Iron Pipe Flanges" 10K flanges.

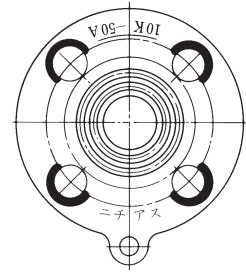
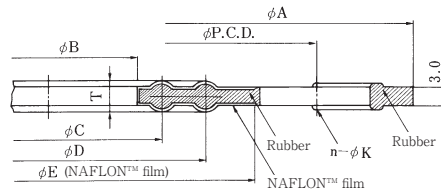

[Dimension Table 42]

Unit [mm]

Nominal flange diameter		Gasket		Thickness T	Diameter of sealing part		Bolt		Reference E
A	B	O.D. A	I.D. B		C	D	PCD	n-φK	
15	1/2 B	93	18	5	26	41	70	4-15	53
20	3/4	98	22	5	32	47	75	4-15	58
25	1	123	30	5	38	53	90	4-19	68
30/32	1 1/4	133	37	5	50	65	100	4-19	78
40	1 1/2	138	43	5	54	69	105	4-19	82
50	2	153	54	5	68	83	120	4-19	96
65	2 1/2	173	69	5	86	101	140	4-19	116
80	3	183	80	5	98	112	150	8-19	124
100	4	208	102	5	120	138	175	8-19	150
125	5	248	127	5	145	166	210	8-23	180
150	6	278	150	5	168	190	240	8-23	210
200 ⁽¹⁾	8	328	198	5	216	247	290	12-23	260
250	10	398	249	5	270	306	355	12-25	326
300	12	443	300	5	324	352	400	16-25	372

Note: (1) If these gaskets are used with a JIS B 2210 steel flange or a JIS 2220 steel welded flange, the sealing part will shift to the I.D. side of the flange, so please use caution.

For Class 150

■ **Applicable gaskets**

EBILON™ gasket [covered with PTFE] "TOMBO™ No.9013, 9013-D"
 EBILON™ gasket [uncovered rubber] "TOMBO™ No.9013-EP, 9013-DEP"

■ **Applicable flanges**

JPI-7S-15-85
 specified in "Forged steel flange for petroleum industry" of
 JPI standard

*The dimensions of these gaskets have been set by Nichias
 based on the butt-welded flanges stipulated in JPI-7S-15-85.

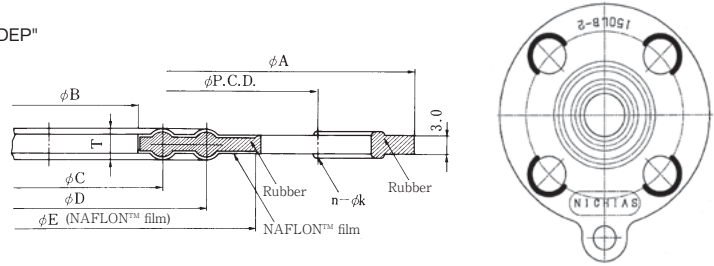

[Dimension Table 43]

Unit [mm]

Nominal flange diameter		Gasket			Diameter of sealing part		Bolt		Reference E
A	B	O.D. A	I.D. B	Thickness T	C	D	PCD	n-φK	
15	1/2	85	18	5	30	—	60.3	4-16	42
20	3/4	95	22	5	32	44	69.9	4-16	52
25	1	103	29	5	38	50	79.4	4-16	60
(32)	(1 1/4)	111	39	5	47	59	88.9	4-16	70
40	1 1/2	121	44	5	53	68	98.4	4-16	79
50	2	146	55	5	65	83	120.7	4-19	99
65	2 1/2	173	70	5	81	101	139.7	4-19	118
80	3	186	81	5	94	112	152.4	4-19	130
(90)	(3 1/2)	210	91	5	110	134	177.8	8-19	154
100	4	223	103	5	124	148	190.5	8-19	168
(125)	(5)	249	128	5	150	174	215.9	8-22	190
150	6	274	152	5	172	196	241.3	8-22	212
200	8	337	200	5	222	246	298.5	8-22	270
250	10	401	251	6	276	300	362.0	12-25	330
300	12	477	302	6	335	365	431.8	12-25	400

Basic Items Concerning Gaskets

■ Gasket tightening criteria

It is very important from the viewpoint of safety to tighten gaskets using an appropriate force and tightening method.

The numeric values "Wm₁" and "Wm₂" which are stipulated in "JIS B 8265 (Construction of pressure vessel -- General principles)" are generally used as a rough guide for the necessary tightening force for sealing the internal fluid.

However, depending on the type of fluid and the conditions of usage, the tightening force calculated by "Wm₁" and "Wm₂" may sometimes be insufficient, therefore Nichias has set an additional value "Wm₃."

When tightening a gasket, it is necessary to apply a force that is at least the largest of the values "Wm₁," "Wm₂," and "Wm₃."

■ Way of thinking concerning calculation of tightening

- Effective diameter and effective width of a gasket -

A flange bends slightly (flange rotation) due to tightening of the bolts and internal pressure, causing the convex part to swell, as shown in the diagram.

As a result, the contact pressure applied to the gasket becomes stronger on the O.D. side and weaker on the I.D. side, and it is considered that this causes the internal fluid to seep to the center part of the gasket. This is taken into account in the determination of the effective diameter and effective width of the gasket.

● Effective width of a gasket:

This is the gasket width of the part that actually seals the flange.

● Effective diameter of a gasket:

This is the diameter of the part to which the internal fluid seeps.

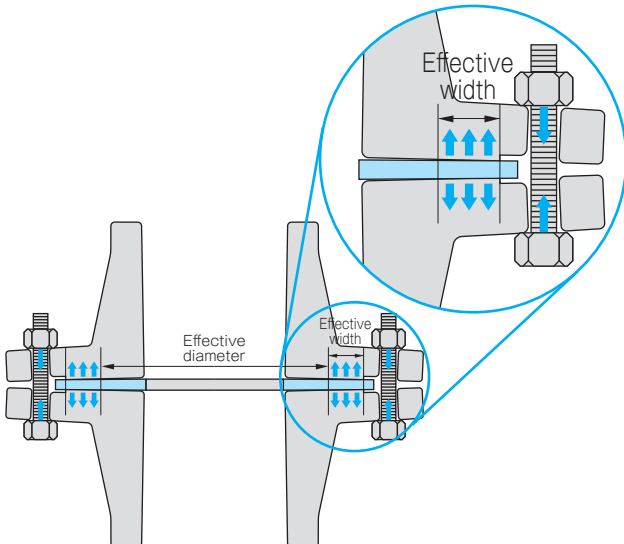

■ Determining the effective diameter and effective width of a gasket

● First, consider the basic width (b₀) of the gasket.

The basic width of the gasket differs according to the shape of the gasket seat. Generally, it is one half of the gasket contact width.

$$b_0 = \text{Gasket contact width} / 2$$

● Effective width of gasket (b)

Using the basic width of the gasket as a rough guide, obtain the effective width of the gasket using the following equation.

$$\text{When } b_0 \leq 6.35\text{mm } b = b_0$$

$$\text{When } b_0 > 6.35\text{mm } b = 2.52\sqrt{b_0}$$

● Effect diameter of gasket (G)

Using the basic width of the gasket as a rough guide, obtain the effective diameter of the gasket using the following equation.

$$\text{When } b_0 \leq 6.35\text{mm}$$

$$G = \text{Mean diameter of the gasket contact face}$$

$$\text{When } b_0 > 6.35\text{mm}$$

$$G = \text{O.D. of gasket contact face} - 2b$$

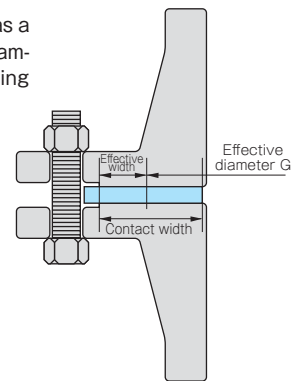

■ Meaning of Wm₁, Wm₂, and Wm₃

● Wm₁ is the necessary minimum tightening force [N] for preventing the flange from opening under internal pressure. It is obtained using the following equation.

$$Wm_1 = H + Hp$$

H: Force (H) tends to open the flange due to internal pressure. This force is called end force (internal pressure reaction).

$$H = \frac{\pi}{4} G^2 P$$

Hp: Necessary force for sealing the fluid when internal P exists

$$Hp = 2\pi b G m P$$

Over the effective area of the gasket, Hp becomes m (gasket coefficient) times the internal pressure P. Normally a value of twice this is used in the calculation in order to provide a safety margin.

$$\text{This is summarized in the following equation.}$$

$$Wm_1 = H + Hp = \frac{\pi G P}{4} (G + 8bm)$$

● Wm₂ is the necessary minimum tightening force [N] for preventing leakage due to penetration or through contact surfaces. It is obtained using the following equation.

$$Wm_2 = \pi b G y$$

● Wm₃ is the necessary minimum tightening force [N] which takes account of the contact area of the gasket. It is obtained using the following equation.

$$Wm_3 = \sigma_3 A_g$$

P = Internal pressure [MPa]

b = Effect width of gasket [mm]

G = Effective diameter of gasket

m = Gasket coefficient [-] (The ratio between the minimum effective tightening pressure at which leakage does not occur, and the internal pressure)

y = Minimum design seating stress [N/mm²]

σ₃ = Minimum seating stress [N/mm²]

A_g = Gasket contact area (projected area) [mm²]

■ Gasket tightening force

Take the gasket tightening force from the maximum value between W_{m1} , W_{m2} and W_{m3} . Note, however, that it is necessary to ensure that this value is no greater than the allowable seating stress, to prevent compression failure of the gasket.

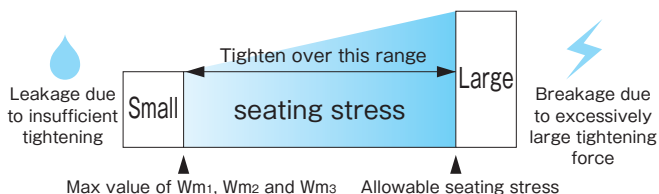

■ Calculating the tightening torque

The tightening torque of the bolts is calculated from the maximum value [W_{max}] of W_{m1} , W_{m2} and W_{m3} .

$$T = \frac{1}{1000} K \frac{W_{max}}{n} D$$

T = Tightening torque of bolts [N·m]
 K = Torque coefficient [-] (Normally 0.20)
 n = Number of bolts [-]
 D = O.D. of bolts [mm]

■ JIS B 2251-2008 Bolt tightening for pressure boundary flanged joint assembly

A widely used method of tightening the bolts is called "diagonal tightening." This method involves tightening diagonally opposite pairs of bolts in sequence. In 2008, however, JIS B 2251 which covered the method of tightening jointing sheets and also the flange coupling of VORTEX™ type gaskets was enacted. This method is described below.

<Introduction>

Install a gasket correctly centered on the gasket seat to ensure that it is not tightened unevenly. Use a torque wrench to control the tightening torque.

<Temporary tightening>

If there are 8 or less flange bolts, temporarily tighten the bolts using the following procedure. If there are 12 or more bolts, select the bolts to be temporarily tightened according to Table 1, and tighten the bolts in the same way as that for 8 or less bolts.

- ① Tighten diagonally opposite pairs of bolts in sequence, as shown in Fig. 1.
- ② Increase the tightening torque in stages (for example 10% → 20% → 60% → 100%), and tighten the bolts evenly.
- ③ Using vernier calipers, measure the clearance between the flange faces at 4 diagonally opposed locations, and check to ensure that the bolts are not tightened unevenly.

* In the case of a VORTEX™ gasket, at the end of temporary tightening, tighten all bolts to 50% of the target torque in the clockwise direction rotation (to prevent uneven tightening).

* Setting the target tightening torque
 When there are 8 or less bolts: 100% of the specified tightening torque
 When there are 12 or more bolts: 110% of the specified torque

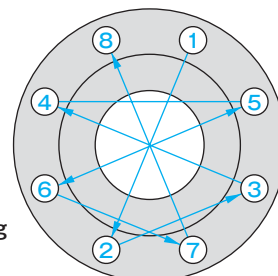

Fig.1 Diagonal tightening procedure

Table 1 Bolt selection criteria

Number of flange bolts	Selection criterion
12 or more, up to 24	4 bolts equally spaced at 90°
Over 24	4 bolts equally spaced by 90°, and 4 bolts separated by 45° from each of the first 4 bolts (Total of 8 bolts)

<Final tightening>

- ① If there are 4 flange bolts, tighten diagonally to 100% of the specified torque.
- ② If there are 8 or more flange bolts, tighten them clockwise the number of turns indicated in the table below.

Nominal flange diameter	Number of turns
Less than 250A	4 turns
250A or more	6 turns

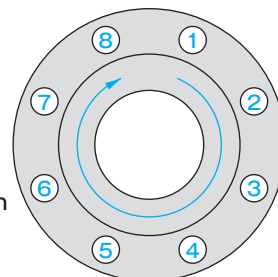

Fig.2 Tightening in the clockwise direction

<Additional tightening>

If it is necessary to additionally tighten the bolts, wait for at least 4 hours after the completion of final tightening, and then tighten the bolts an additional 1 to 2 turns using the same procedure.

Gasket design criteria list

Jointing sheets

TOMBO™ No.		1120	1995	1993	
Gasket coefficient m [-]	0.8 t		3.50		
	1.5 t		2.75		
	3.0 t		2.00		
Min design seating stress y [N/mm ²]	0.8 t		44.8		
	1.5 t		25.5		
	3.0 t		11.0		
Min seating stress σ_3 [N/mm ²]	Water-type and oil-type fluids		14.7		
	Gas-type fluids		34.3		
Allowable seating stress	Without paste [N/mm ²]	0.8 t	294.2		
		1.5 t	196.1		
		3.0 t	98.0	147.1	
	With paste [N/mm ²]	0.8 t	68.6 ⁽¹⁾		
		1.5 t			
		3.0 t			

Note: (1) The allowable seating stress when anti-corrosion paste is used is 58.8 N/mm².

Fluoropolymer gaskets

TOMBO™ No.	1133	9007-SC	9007-LC	9007-GL	9007-FD	9096-SGM	9007	9007-LP	9007-G20	
Gasket coefficient m [-]	1.0 t	3.50	—	3.50	—	—	2.50	3.50	—	3.50
	1.5 t	2.75	3.20	3.20	—	—	2.50	3.20	—	3.20
	2.0 t	2.75	3.00	3.00	—	—	2.50	3.00	3.00	3.00
	3.0 t	2.00	2.50	2.50	2.50	2.50	2.50	2.50	—	2.50
Min. design seating stress y [N/mm ²]	1.0 t	44.8	—	24.5	—	—	19.6	24.5	—	24.5
	1.5 t	25.5	22.6	22.6	—	—	19.6	22.5	—	22.5
	2.0 t	25.5	19.6	19.6	—	—	19.6	19.6	19.6	19.6
	3.0 t	11.0	19.6	19.6	19.6	19.6	19.6	19.6	—	19.6
Min. seating stress σ_3 [N/mm ²]	Water-type and oil-type fluids	14.7	14.7	14.7	19.6	19.6	19.6	10.8	14.7	12.7
	Gas-type fluids	34.3	29.4	24.5	14.7	—	39.2	19.6 ⁽¹⁾ 14.7 ⁽²⁾	14.7	19.6 ⁽¹⁾ 14.7 ⁽²⁾
Allowable seating stress	150.0	58.8	49.0	39.2	39.2	117.6 ⁽³⁾	39.2	29.4	49.0	

Note: (1) Minimum seating stress for thickness of 1.0 t or 1.5 t (2) Minimum seating stress for thickness of 2.0 t or 3.0 t (3) Allowable seating stress for thickness of 2.0 t or 3.0 t is 78.4 N/mm².

NAFLON™ PTFE envelope gaskets

Shape	Type A		Type B	Type AS	
Core material [TOMBO™ No.]	1995 (Type 5) 1995+Felt (Type 6) 1120 (Type 7) 1120+Felt (Type 8)	1120+SUS mesh (Type 9)	1995 (Type 5) 1995+Felt (Type 6) 1120 (Type 7) 1120+Felt (Type 8)	1995 (Type 5) 1995+Felt (Type 6) 1120 (Type 7) 1120+Felt (Type 8)	1120+SUS mesh (Type 9)
Gasket coefficient m [-]	3.50		4.00	3.50	
Min. design seating stress y [N/mm ²]	14.7		19.6	14.7	
Min. seating stress σ_3 [N/mm ²]	Water-type and oil-type fluids	9.8	14.7	9.8	14.7
	Gas-type fluids	14.7	19.6	14.7	19.6
Allowable seating stress	29.4		39.2	29.4	

GRASEAL™ gaskets

TOMBO™ No.	1880-GR	1215-A	1210-A	1200
Gasket coefficient m [-]	2.00	2.00	2.00	2.00
Min. design seating stress y [N/mm ²]	26.0	29.4	29.4	26.0
Min. seating stress σ_3 [N/mm ²]	Water-type and oil-type fluids	14.7	14.7	14.7
	Gas-type fluids	39.2	49.0	49.0
Allowable seating stress	0.8 t	—	294.0	170.0
	1.6 t	166.0	167.0	167.0 ⁽¹⁾
	3.2 t	166.0	98.0	79.0

Note: (1) Allowable seating stress of TOMBO™ No.1210-A shows the value of 1.5t.

■ Kammprofile gaskets

TOMBO™ No.	1891-GR	1891-TF
Gasket coefficient m [-]	2.25	
Min design seating stress γ [N/mm ²]	15.2	
Min seating stress σ_3 [N/mm ²]	Water-type and oil-type fluids	29.4
	Gas-type fluids	39.2
Allowable seating stress [N/mm ²]	450	

■ VORTEX™ gaskets

TOMBO™ No. ⁽¹⁾	1804-GR	1804-NA	9090	1806-GS, -GM, -GH	1809, 1809-A L
Gasket coefficient m [-]	3.00				3.00
Min design seating stress γ [N/mm ²]	68.9				58.8
Min seating stress σ_3 [N/mm ²]	Water-type and oil-type fluids	29.4	34.3	29.4	34.3
	Gas-type fluids	39.2	78.4	39.2	78.4
Allowable seating stress [N/mm ²]	294.2				294.2

Note: (1) Indicates the TOMBO™ No. for basic type.

■ Metal jacketed gaskets

TOMBO™ No.	1841-S	1841-E 1841-G, others	1841-C	1841-A	1861-S	1861-E 1861-G, others	1861-C	1861-A
Cover metal material	Carbon steel	304 stainless steel 316 stainless steel, others	Copper	Aluminum	Carbon steel	304 stainless steel 316 stainless steel, others	Copper	Aluminum
Gasket coefficient m [-]	3.75	3.75	3.50	3.25	3.00	3.50	3.25	2.50
Min. design seating stress γ [N/mm ²]	52.4	62.1	44.8	38.0	31.0	44.8	38.0	20.0
Min. seating stress σ_3 [N/mm ²]	Water-type and oil-type fluids	39.2	49.0	34.3	29.4	—	—	—
	Gas-type fluids	101.4	120.4	76.2	58.8	—	—	—

■ Plain type metallic gaskets

TOMBO™ No.	1850-P-S	1850-P-E, P-G, others	1850-P-C	1850-P-A
Material	Carbon steel	304 stainless steel, 316 stainless steel, others	Copper	Aluminum
Gasket coefficient m [-]	5.50	6.50	4.75	4.00
Min. design seating stress γ [N/mm ²]	124.2	179.3	89.6	60.7
Min. seating stress σ_3 [N/mm ²]	Water-type and oil-type fluids	98.1	117.7	58.8
	Gas-type fluids	235.4	343.2	98.1

■ Serrated metallic gaskets

TOMBO™ No.	1890-S	1890-E, 1890-G, others	1890-C	1890-A
Material	Carbon steel	304 stainless steel, 316 stainless steel, others	Copper	Aluminum
Gasket coefficient m [-]	3.75	4.25	3.50	3.25
Min. design seating stress γ [N/mm ²]	52.4	69.6	44.8	38.0

■ Ring joint gaskets

TOMBO™ No.	1850-C-D, 1850-V-D	1850-C-S, 1850-V-S	1850-C-F, 1850-V-F	1850-C-E, 1850-C-G 1850-V-E, 1850-V-G, others
Material	Pure iron	Mild steel	F5	Stainless steel
Gasket coefficient m [-]	5.50		6.00	6.50
Min. design seating stress γ [N/mm ²]	124.2		150.3	179.3

Gasket standard dimension list

Jointing sheets

TOMBO™ No.		1120	1995	1993	1991-NF	1938
1S (1270×1270mm)	0.4 t	●	—	—	●	—
	0.5 t	●	—	●	●	—
	0.8 t	●	●	●	●	—
	1.0 t	●	●	●	●	●
	1.5 t	●	●	●	●	●
	2.0 t	●	●	●	—	●
3S (1270×3810mm)	0.4 t	●	—	—	●	—
	0.5 t	●	—	●	●	—
	0.8 t	●	●	●	●	—
	1.0 t	●	●	●	●	—
	1.5 t	●	●	●	●	—
	2.0 t	●	●	●	—	—
6S (2540×3810mm)	0.8 t	●	—	—	—	—
	1.0 t	●	●	—	—	—
	1.5 t	●	●	—	—	—
	2.0 t	●	●	—	—	—
9S (3810×3810mm)	0.8 t	—	—	—	—	—
	1.0 t	—	—	—	—	—
	1.5 t	—	●	—	—	—
	2.0 t	—	●	—	—	—
Weight per sheet of thickness 1.5 t and 1S size [kg] (reference value)		3.63	4.35	4.23	3.75	4.35

* The above dimensions are standard dimensions. Note that we may be able to manufacture jointing sheets of dimensions that are not marked with ●. Please contact us for details.

Fluoropolymer gaskets

TOMBO™ No.		1133	9007-SC	9007-LC	9007-GL	9007-FD	9096-SGM	9007	9007-LP	9007-G20
Max. O.D. [mm]	1.0 t	φ610	—	—	—	—	φ1380	φ1200	φ277	φ1200
	1.5 t	φ1250	φ1200	φ1200	—	—	φ1380	φ1200	φ277	φ1200
	2.0 t	φ1250	φ1200	φ1200	—	—	φ1380	φ1200	φ277	φ1200
	3.0 t	φ1430	φ1200	φ1430	φ600	φ1220	φ1380	φ1200	φ277	φ1200
Standard thickness	1.0 t	●	—	●	—	—	●	●	—	●
	1.5 t	●	●	●	—	—	●	●	—	●
	2.0 t	●	●	●	—	—	●	●	●	●
	3.0 t	●	●	●	●	●	●	●	—	●

* The pale blue parts in the table indicate that the gaskets concerned can be manufactured to a larger bore than indicated, by carrying out welding work.

* The blue parts in the table indicate that the gaskets concerned can be manufactured to a larger bore than indicated, by carrying out bonding work.

NAFLON™ PTFE envelope gaskets

Shape		Type A	Type B	Type AS
Min. I.D. [mm]		φ16	φ300	φ20
Max. O.D. [mm]		φ1000	Arbitrary	φ700

GRASEAL™ gaskets

TOMBO™ No.		1880-GR	1215 1215-T	1215-A 1215-AT	1215-B-E04 1215-BT-E04	1215-B-E10 1215-BT-E10	1210-A	1200
Nominal thickness [mm]		1.6, 3.2	0.8, 1.6, 3.2	0.8, 1.6, 3.0	1.2, 2.0	1.8, 2.6	1.5, 2.0, 3.0	0.4, 0.8, 1.6, 3.2
Thickness of reinforcing sheet [mm]		0.8	0.10	0.05	0.40	1.00	0.10	—
Diameters to which gaskets can be manufactured [mm]		φ3300 ⁽¹⁾	φ580	φ1480 ⁽³⁾	φ985 ⁽²⁾	φ985 ⁽²⁾	φ1480	φ985
Min. width [mm]		10	10	5	5	10	—	—

Note: (1) For a dimension that exceeds φ3300, please consult us.

(2) If the O.D. of the gasket exceeds 900mm, weld a steel sheet of 0.4mm or 1.0mm at several points, or bond an expanded graphite sheet at several points.

(3) The maximum diameter dimension to which a gasket of nominal thickness of 0.8mm can be manufactured is φ985mm.

■ Kammprofile gaskets

Standard O.D. [mm]	φ 4000 ⁽¹⁾
Standard thickness [mm]	4.0 (Metal thickness: 3.0, Thickness of cover material: 0.5×2 = 4.0)
Standard width [mm]	10, 13, 15, 20
Min. width to which gasket can be manufactured [mm]	5 ⁽²⁾
Standard metal body material	304 stainless steel, 316L stainless steel
Standard hanger material	304 stainless steel
Construction	Standard type, hanger type, branch type

Note: (1) For a diameter exceeding φ 4000mm, please consult us. We can also manufacture gaskets to specifications other than those shown at left, as special products. However, from a structural viewpoint, we are unable to manufacture a gasket with bolt holes for a full-face seat or one with an irregular profile (track type, oval type, etc.). In such a case, please consider the use of TOMBO™ No.1880-GR (CMGC gasket).
(2) Indicates the minimum width to which a gasket can be manufactured. The sealable width differs depending upon the conditions of use, so please be careful.

■ VORTEX™ gaskets

Gasket thickness ⁽¹⁾ [mm]	Inner/outer ring thickness [mm]		Recommended I.D. for manufacture ⁽²⁾ [mm]	
	Carbon steel	Other than carbon steel	Min.	Max.
3.2	2.0	2.0	φ 16	φ 600
4.5 (Standard)	3.2	3.0	φ 16	φ 3000
6.4	4.5	4.0	φ 1500	φ 3000

Note: (1) When using this gasket for a pipe flange, use a gasket thickness of 4.5mm, as a general rule.

(2) We can also manufacture gaskets to dimensions other than the above. However, this may result in deformation, warping or breaking up of the gaskets, and also the delivery period may be longer than normal due to the custom specifications, so please consult us separately.

■ Metal jacketed gaskets

Cover metal material	Carbon steel	304 stainless steel	316 stainless steel	Copper	Aluminum	310S stainless steel
Material symbol	S	E	G	C	A	V
Standard dimensions [mm]	1480	1180	1180	1180	980	1180

* Indicates the larger diameter to which a gasket can be manufactured using a single metal sheet. We can manufacture larger gaskets by welding at two or more points.

■ Metal O seals

Tube cross-sectional diameter [mm]	Thickness [mm]	O.D. [mm]	
		Recommended range of use	Manufacturable dimensions
φ 0.8	0.15	6 ~ 25	6 ~ 30
φ 1.6	0.25	—	12 ~ 200
	0.36	15 ~ 50	11 ~ 200
φ 2.4	0.25	—	40 ~ 500
	0.46	40 ~ 200	20 ~ 500
φ 3.2	0.25	—	70 ~ 1500
	0.35 ⁽¹⁾	—	60 ~ 1500
	0.5	65 ~ 700	50 ~ 1500
φ 4.8	0.5 ⁽¹⁾	—	150 ~ 1500
	0.8	500 ~ 1200	150 ~ 1500
φ 6.4	0.8	1000 ~ 1500	250 ~ 1500 ⁽²⁾

 Indicates the standard thickness. In the case of a gas seal, use the seal with standard thickness.

 The minimum O.D. of a vent-hole type is φ 10mm.

 The maximum O.D. of a PTFE coating is φ 1300, and that of a silver coating is φ 1100.

Note: (1) The manufacturable tube material is limited to SUS321 stainless steel.

(2) If you require a gasket exceeding 1500mm, please consult us.

Minimum value of the corner rounding in the case of a square gasket

For a standard thickness ( part)

R at the I.D. side ≤ 6 times the O.D. of the tube

When the thickness is thinner than the standard value

R at the I.D. side ≤ 8 times the O.D. of the tube

■ Rubber cut gaskets

Thickness [mm]	Width [mm]	Max. O.D. [mm]
1.0	1,000	φ 1,000
1.5		
2.0		
3.0		
5.0		
10.0		

* The maximum O.D. for ZR or PF of a thickness of 1.0mm, 1.5mm, 2.0mm or 3.0mm is φ 300mm.

* The minimum thickness of a cloth filled NR is 1.5mm.

■ SANICLEAN™ gaskets

Nominal dimension [inches]	TOMBO™ No.					
	9014-A (for screw coupling) [mm]			9014-B (for ferrule) [mm]		
	φ A	φ B	φ C	φ A	φ B	φ C
1	32.5	29.2	23.0	49.5	43.5	23.1
1 1/2	46.0	42.7	35.6	49.5	43.5	35.8
2	59.5	56.2	47.8	63.0	56.5	48.0
2 1/2	73.0	69.9	59.5	76.5	70.5	59.7
3	86.5	82.6	72.1	90.0	83.5	72.3
4	112.5	108.3	97.6	118.0	110.0	97.8

* The standard dimensions of TOMBO™ No.9014-A, B are determined based on the IDF standard. However, you can also use these gaskets for screw coupling and clamp type couplings that conform to ISO2852 and ISO2853.

■ EBILON™ gaskets

- Plastic flanges (equivalent to JIS 10K) 15A - 300A
- JPI Class 150 1/2 - 24B

■ Rubber O rings

- JIS B 2401 "O rings"
- AS 568B "O rings for hydraulic applications in aircraft"
- JIS B 8365 "Dimensions of clamped-type vacuum couplings"

Note





NICHIAS Corporation

Head Office

6-1, Hatchobori 1-chome, Chuo-ku, Tokyo 104-8555, Japan
International Marketing and Sales Group
Phone: 81-3-4413-1132 Fax: 81-3-3552-6108
Web Site: <http://www.nichias.co.jp/>

Overseas Sales Companies

Indonesia

PT. NICHIAS SUNIJAYA

Panin Life Center, 2nd Floor, Room 205, Jl. Letnan Jenderal S. Parman Kav. 91, Jakarta 11420, Indonesia
Phone: +62-21-56956207 Fax: +62-21-56956208/56956209

Malaysia

NICHIAS SOUTHEAST ASIA SDN. BHD.

Suite A1102, 11th Floor, West Wing, Wisma Consplant 2, No. 7, Jalan SS 16/1, 47500 Subang Jaya, Selangor Darul Ehsan, Malaysia.
Phone: +60-3-5636-4067 Fax: +60-3-5636-4078

Singapore

NICHIAS SINGAPORE PTE. LTD.

25 International Business Park, #01-15/17 German Centre, Singapore 609916
Phone: +65-6571-0830/0838 Fax: +65-6265-7681

Vietnam

NICHIAS VIETNAM CO., LTD

Room 12-K, 12Floor, Center Building, Hapulico Complex No1 Nguyen Huy Tuong, Thanh Xuan Trung, Thanh Xuan, Hanoi, Vietnam
Phone: + 84-4-3791-7194 Fax: + 84-4-3791-6203

Thailand

NICHIAS (THAILAND) CO., LTD.

85 Moo 1, Wellgrow Industrial Estate T. Homsin, A. Bangpakong Chachoengsao 24180, Thailand
Phone: +66-38-570-600 Fax: +66-38-570-601

THAI NICHIAS INTERNATIONAL CO., LTD.

Unit 1107, 11th Floor, AIA Capital Center 89 Ratchadaphisek Road, Dindaeng, Dindaeng, Bangkok 10400 Thailand
Phone: +66-2-001-2060 Fax: +66-2-001-2062

China

NICHIAS (SHANGHAI) TRADING CO., LTD.

霓佳斯（上海）贸易有限公司
Room 1701, THE PLACE, Tower A, No. 100 Zun Yi Road, Changning District, Shanghai, P.R.China Postcode 200051
中国上海市长宁区遵义路100号虹桥南丰城A栋1701室 邮编200051
Phone: +86-21-6236-1783 Fax: +86-21-6236-1781

NICHIAS (SHANGHAI) TRADING CO., LTD. Guangzhou Branch

霓佳斯（上海）贸易有限公司 广州分公司
17F-G, Gold Sun Building, No.109 Tiyu West Road, Guangzhou, Guang Dong Province, 510620, P.R.China
中国广东省广州市天河区体育西路109号高盛大厦17楼G室 邮编 510620
Phone: +86-20-3879-1640 Fax: +86-20-3879-1647

NICHIAS (SHANGHAI) AUTOPARTS TRADING CO., LTD.

霓佳斯（上海）汽车零部件贸易有限公司
Room 1702, THE PLACE, Tower A, No. 100 Zun Yi Road, Changning District, Shanghai, P.R.China Postcode 200051
中国上海市长宁区遵义路100号虹桥南丰城A栋1702室 邮编200051
Phone: +86-21-6236-2668 Fax: +86-21-6236-2667

Germany

NICHIAS AUTOPARTS EUROPE GmbH

Prinzenallee 7, 40549 Düsseldorf, Germany
Phone: +49 (0)211-52391-058 Fax: +49 (0)211-52391-200

United Kingdom

NICHIAS EUROPE (UK) LTD

10th Floor, Hardman Street, Manchester, M3 3HF, UK
Phone: +44-0-161-932-1422 Fax: +44-0-161-932-1401

Overseas Construction Companies

Malaysia

NICHIAS SOUTHEAST ASIA SDN. BHD.

Suite A1102, 11th Floor, West Wing, Wisma Consplant 2, No. 7, Jalan SS 16/1, 47500 Subang Jaya, Selangor Darul Ehsan, Malaysia.
Phone: +60-3-5636-4067 Fax: +60-3-5636-4078

Thailand

THAI-NICHIAS ENGINEERING CO., LTD.

45 Huaypong-Nongbon Road, Huaypong, Muang Rayong, Rayong Province 21150, Thailand
Phone: +66-38-682-242 Fax: +66-38-691-156

Overseas Factories

Indonesia

PT. NICHIAS ROCKWOOL INDONESIA

PT. NICHIAS METALWORKS INDONESIA

Malaysia

NICHIAS FGS SDN. BHD.

NT RUBBER-SEALS SDN. BHD.

Vietnam

NICHIAS HAIPHONG CO., LTD.

China

SUZHOU NICHIAS INDUSTRIAL PRODUCTS CO., LTD.

(苏州霓佳斯工业制品有限公司)

SUZHOU NICHIAS SEAL MATERIAL CO., LTD.

(苏州霓佳斯密封材料有限公司)

SHANGHAI XINGSHENG GASKET CO., LTD.

(上海兴盛密封垫有限公司)

SHANGHAI GOYU AUTO PARTS CO., LTD.

(上海五友汽车零部件有限公司)

India

NICHIAS INDUSTRIAL PRODUCTS PRIVATE LTD.

Czech

NICHIAS AUTOPARTS EUROPE a.s.

Mexico

NAX MFG, S.A.DE C.V.

⚠ Cautions

- 1) The information and recommendation in this catalog are based on our present state of knowledge and given in good faith for customer guidance purpose, and no liability will be accepted in relation to the same.
- 2) Properties/applications shown in this catalog are typical. The products shown in this catalog shall not be used for any purpose other than prescribed application.
- 3) Performance data shown in this catalog are developed from in-house testing and/or field reports from customers. Failure to select the proper products could result in property damage and/or serious personal injury.
- 4) Performance verification under actual operating conditions is recommended even for the application shown in this catalog.
- 5) While the utmost care has been used in compiling this catalog, we assume no responsibility for errors. This edition cancels previous issues and contents of this catalog are subject to change without prior notice.
- 6) For safe handling recommendations and health related effects, refer to the safety data sheet (SDS) of each product, available on request.
- 7) All or any part of the content on this catalog may not be copied, duplicated, imitated, reused and reproduced without prior permission of NICHIAS Corporation.

