

HF-251

Issued August 2007 • Index No. AY/5.0

High-Frequency Arc Starter and Stabilizer

Quick Specs

Industrial/Light Industrial Applications

General Manufacturing
Tool and Die
Repair Shops
All-Purpose Maintenance

Processes

Gas Tungsten Arc
Welding (TIG)

Input Power 1-Phase Power

Rated Output 250 A, 60% Duty Cycle

Weight HF-251D-1: 34 lb (15 kg)
HF-251-2: 36 lb (16 kg)

The Power of Blue.®

The HF-251 is compatible with power sources made by other manufacturers. For use with power sources with 14-pin receptacle (5-pin adapter available).

Increase the flexibility and performance of most AC, DC or AC/DC constant-current welding machines with these portable high-frequency arc starters and stabilizers. The unit impresses high frequency on the welding circuit and provides the arc control needed for TIG welding.

With the addition of an HF unit, your constant-current power source can handle welds on aluminum, magnesium, thin stainless steel, brass, copper and a wide variety of both ferrous and non-ferrous alloys.

Two versions (115 VAC, 50/60/100 Hz and 230 VAC, 50/60 Hz) meet most single-phase power configurations, and all are rated at 60% duty cycle.



Power on/off switch with pilot light.

Start, off and continuous control.

Gas solenoid valve.

High-frequency intensity control.

Built-in postflow eliminates contamination.

Protected secondary terminal.

Convenient, portable design can be easily moved from location to location.

14-pin receptacle on front panel for remote controls.

Specifications (Subject to change without notice.)

1
Phase

Model	Input Volts	Rated Output at 60% Duty Cycle	Dimensions	Net Weight
HF-251D-1	115 VAC, 50/60/100 Hz	250 A	H: 13 in (330 mm) W: 9-1/4 in (235 mm) D: 16 in (406 mm)	34 lb (15 kg)
HF-251-2	230 VAC, 50/60 Hz			36 lb (16 kg)



Warranted for 1 year, parts and labor.

MADE IN USA
APPLETON, WI 



Miller Electric Mfg. Co.
An Illinois Tool Works Company
1635 West Spencer Street
Appleton, WI 54914 USA

International Headquarters
Phone: 920-735-4505
USA FAX: 920-735-4134
Canadian FAX: 920-735-4169
International FAX: 920-735-4125

Web Site
www.MillerWelds.com



Control Panel

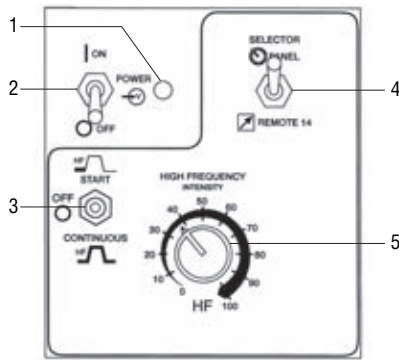

1. Pilot Light
2. Power Switch
3. High Frequency Switch
4. High Frequency Selector Switch
5. High Frequency Intensity Control

Typical Installations

□ Denotes Plug (Threaded Collar) □ Denotes Receptacle (External Threads)

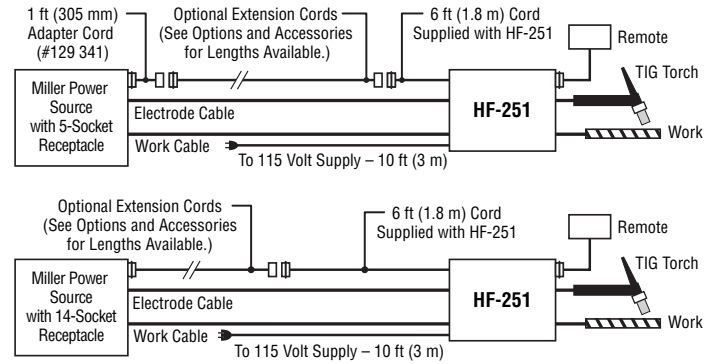

Genuine Miller Options and Accessories



Secondary Contactor Kit

For HF-251D-1 model
#041 969 Field only
 For HF-251-2 model
#041 906 Field only

Mounts inside HF-251 cabinet. For use with a power source that does not have its own contactor.

RHC-14 #129 340

Miniature remote hand current and contactor control. Includes 20 ft (6 m) cord and 14-pin plug.



RFCS-14 #043 554

Foot pedal current and contactor control. Includes 20 ft (6 m) cord and 14-pin plug.

Extension Cords

#122 973 25 ft (7.6 m)

#122 974 50 ft (15 m)

#122 975 75 ft (23 m)

Extends HF-251 farther from power source or extends remote control farther from HF-251.

Adapter Cord #129 341

1 ft (305 mm) cord with 5-pin and 14-pin plugs for use between 5-socket receptacle power source and HF-251.

Adapter Cord #041 947

1 ft (305 mm) cord with 14-pin plug and 5-socket receptacle for use between HF-251 and 5-pin remote controls.

Water Coolant Systems

Coolmate™ 3

#043 007 115 VAC

#043 008 230 VAC

Delivers cooling capacity for torches rated up to 600 A.

Coolmate™ V3 #043 009 115 VAC

Cools torches rated up to 500 A.

Coolmate™ 4 #042 288 115 VAC

Cools torches and guns rated up to 600 A.

For use with water-cooled guns. Refer to Literature Index No. AY/7.2 for additional coolant system information.

Typical TIG (GTAW) Torches

Air-cooled Torches

#WP-17-25-2 (150 Amp)

#WP-26-25-2 (200 Amp)

Water-cooled Torches (Requires 45VII Adapter)

#WP-18-25-R (350 Amp)

#WP-20-25-R (250 Amp)

Ordering Information

Power Source and Options	Stock No.	Description	Qty.	Price
HF-251D-1	#042 388	115 V, 50/60/100 Hz		
HF-251-2	#042 387	230 V, 50/60 Hz		
Secondary Contactor Kit	#041 969 #041 906	For HF-251D-1 model. Field only For HF-251-2 model. Field only		

Date:

Total Quoted Price:



Distributed by: