

Warrior™ 500i with Warrior Feed 304



- Designed with input from real-world welders and built with ESAB's leading-edge engineering
- Multi-Process - Warrior is designed for GMAW, FCAW (Flux-Cored), SMAW, and GTAW applications, as well as ACAG (Arc Gouging), and delivers up to 500A @ 60% duty cycle
- Welds .030-5/64 in. (0.8-2.4 mm) flux cored and solid wires
- Great short arc performance with 500A
- Full range of SMAW capabilities with excellent 7018 and 6010 performance
- Arc gouges with electrodes up to 3/8 in. (5 mm)
- Inverter technology - increased energy efficiency and more power from a lighter, smaller, and more portable unit
- Generator friendly - compatible to work with generators when power is not accessible in the field
- AutoFan™ feature reduces energy consumption and dirt intake
- High duty cycle for long runs across a variety of applications
- Automatic Hot Start/Variable Arc Control allows the welder to fine-tune the arc to get best possible weld performance and optimize hot start, arc force, and inductance settings with total arc control
- Power, gas, and control cables are in an all-in-one bundle with quick disconnect plugs to reduce setup time, housed in a tough, protective cover for longer cable life
- All controls, including power switch, are located on the all-in-one front panel
- Read-anywhere display - easy to read settings outdoors and from a wide range of angles
- Ergonomically designed handles, built to withstand mechanical hoisting
- Durable and rugged - IP 23 rating for outdoor and indoor use in rough environments



Ordering Information

Warrior 500i Ready to Weld Packages

USA

Warrior 500i, 380/460/575V, 3ph, 5.5 ft. (1.7 m) .. 0558101760
 Warrior 500i, 380/460/575V, 3ph, 32 ft. (9.7 m) .. 0558101761
 Warrior 500i, 380/460/575V, 3ph, 49 ft. (15 m) ... 0558101765

Canada

Warrior 500i, 380/460/575V, 3ph, 5.5 ft. (1.7 m) .. 0561000155
 Warrior 500i, 380/460/575V, 3ph, 16.4 ft. (5 m) .. 0561000156

Includes: power source, 5.5 ft. (1.7 m), 16 ft. (5 m), or 32 ft. (9.7 m) cable connection set, Warrior Feed 304 4-roll wire feeder, .035/.045 in. (0.9/1.2 mm) V-groove drive rolls/guide tube, Tweco Spray Master 450 MIG gun .035-.045 in. (0.9-1.2 mm) accessories, R-33-FM-580 gas regulator/flowmeter, 49 ft. (15 m) work cable/ground clamp. Input power cable is not included.

Canada package also includes trolley with wheels & 1-cylinder rack.

MobileFeed 300AVS Wire Feeder Package

Warrior 500i/MobileFeed, 380/460/575V, 3ph .. 0558101762

Includes: .052/1/16 in. (1.4/1.6 mm) K-groove drive rolls, Tweco Spray Master 450 MIG gun with .052-1/16 in. (1.4-1.6 mm) accessories. Regulator/flowmeter and cylinder cart not included.

Basic Packages

Warrior 500i, 380/460/575V, 3ph, 5.5 ft. (1.7 m) . 0558101759

Includes: power source, feeder, 15 ft. (4.5 m) Tweco Spray Master 450 MIG gun.

Power Source Only

Warrior 500i, 380/460/575V, 3ph..... 0465350881

Warrior Power Source Pack (includes 4 power sources)

Warrior 500i power source 4-pack' 0588002000

'Specify input voltage when ordering.

Warrior™ 500i with Warrior Feed 304



Options & Accessories

Feeder Accessories

Wheel kit	0458707880
Strain relief for welding torch	0457341881
Feeder strain relief for connection cables	0459234880
Lifting eye	0458706880
Quick connector Marathon Pac adaptor	0558002354
Adaptor for 11-lb (5-kg) spool	0455410001
Steel spool cover, 12 in. (305 mm)	0459431880
Remote adaptor kit, Miggytrac/Railtrac	0465451880
M1 remote	0459491895
Remote cable	0459553880

Counterbalance MiniBoom

For 12 in. (305 mm) spools	0458705880
For 18 in. (457 mm) spools	0458705882

Extension arm for 60-lb coil (18 in. spools)	0459233880
Coil adaptor for 60-lb (27.2-kg) coils ¹	34323
Female gas hose quick-connector	0365803002
Gas flow checker	19043
PrecisionMaster gas saver kit	0558007079

¹Requires extension arm #0459233880.

Connection Cable Sets, Air-Cooled Torch

5.6 ft. (1.7 m)	0459836880
32.8 ft. (10 m)	0459836882
49.2 ft. (15 m)	0459836883
82 ft. (25 m)	0459836884

Power Source Accessories

Auto transformer, 208/230/460V, 3ph	0588002040
Warrior 500i spool gun option	0588002061

Electrode Holder Assemblies

175A, 15 ft. (4.5 m)	0558001791
300A, 15 ft. (4.5 m)	21226

Trolley, 1 cylinder	0465510880
Wheel kit	0465416880
Water cooler	0465427880

Remote Controls, power source

Remote kit (required)	0465424880
FS003-B remote foot control, 25 ft. (7.6 m)	0558008905
RCA-2B remote torch control, 25 ft. (7.6 m)	0558008904
Remote control AT1 analog ¹	0459491896
Remote control AT1 course-fine analog ¹	0459491897
Cable interconnect analog 12P, 16.4 ft. (5 m) ..	0459552880
Cable interconnect analog 12P, 33 ft. (10 m) ..	0459552881
Cable interconnect analog 12P, 50 ft. (15 m) ..	0459552882
Cable interconnect analog 12P, 82 ft. (25 m) ..	0459552883

¹Order cable separately.

Work Cable Extensions

16.4 ft. (5 m) - 2/0 AWG	0558101878
33 ft. (10 m) - 2/0 AWG	0558101879
50 ft. (15 m) - 2/0 AWG	0558101880
82 ft. (25 m) - 2/0 AWG	0558101881
82 ft. (25 m) - 4/0 AWG	0558101882
115 ft. (35 m) - 4/0 AWG	0558101883

Control Panel

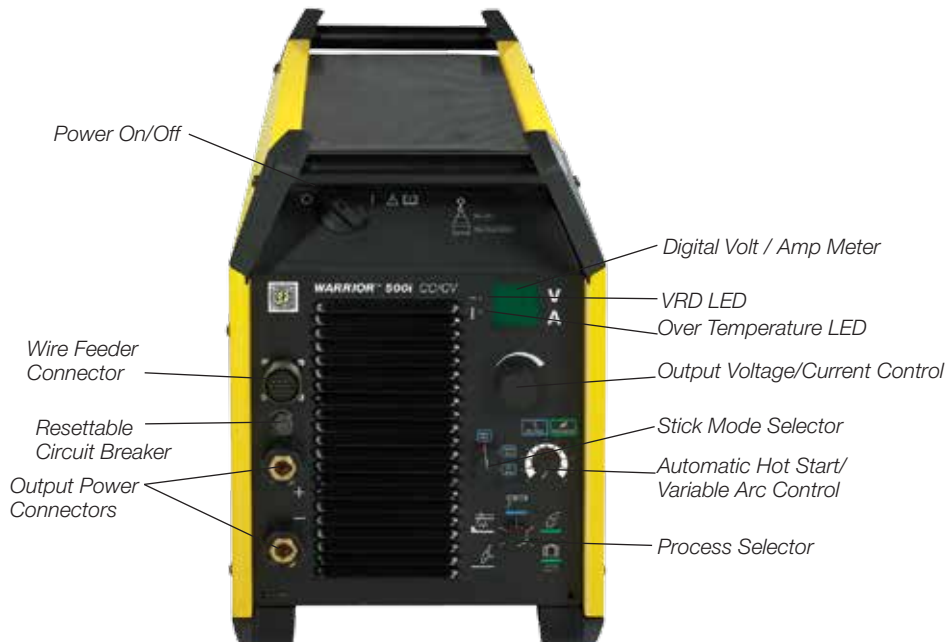

ESAB Welding and Cutting Products

USA: www.esabna.com / 1.800.ESAB.123 | Canada: www.esab.ca / 1.877.935.3226 | Mexico: www.esab.com.mx / (81) 8305-3700

Warrior™ 500i with Warrior Feed 304



Options & Accessories continued

Warrior Feed 304 Wire Feeder

Warrior Feed 304 (CC).....	0465250880
Warrior Feed 304w ¹ (CC).....	0465250881
Warrior Feed 304 for ST-21 & ST-16	0588002048
Warrior Feed 304 NAS ² (TWECO)	0588002068

Warrior Feed 304 has 4-roll drive system and 19 pole amphenol cable connection. Includes digital meters, .035/.045 in. (0.9/1.2 mm) V-groove drive rolls/guide tube and spool enclosure.

¹Includes water solenoid connections.

²Special order upon request.



Mobilefeed 300 AVS 4-Roll Suitcase Wire Feeder

Mobilefeed 300 AVS CC	0558005729
-----------------------------	------------

This optional wire feeder includes digital meter, gas solenoid valve, contactor, LC-40 & OKC male connector and .045-1/16 in. (1.2-1.6 mm) serrated drive rolls.



Feed Roll Kits

V-Groove .023-.030 in. (0.6-0.8 mm).....	0558003134
V-Groove .035-.045 in. (0.9-1.14 mm).....	0558003135
V-Groove .052-.1/16 in. (1.3-1.6 mm).....	0558003136
K-Groove 035-.045 in. (0.9-1.14 mm)	0558003137
K-Groove 045-.052 in. (1.14-1.3 mm)	0558003138
K-Groove 1/16-5/64 in. (1.6-2.0 mm).....	0558003139

GMAW Torches

Tweco Spray Master 450, 10 ft. (3 m), CC	10401075
Tweco Spray Master 450, 12 ft. (3.6 m), CC	10401076
Tweco Spray Master 450, 15 ft. (4.5 m), CC	10401077
Tweco Spray Master 450, 10 ft. (3 m), TWECO....	10401050
Tweco Spray Master 450, 12 ft. (3.6 m), TWECO.	10401051
Tweco Spray Master 450, 15 ft. (4.5 m), TWECO.	10401052
Tweco Spray Master 450, 20 ft. (6 m), TWECO....	10401059
Tweco Spray Master 450, 25 ft. (7.6 m), TWECO.	10401058

GTAW Torches

HW-17V-2TL, 12.5 ft. (3.6 m).....	35857
HW-17V-2TL, 25 ft. (7.6 m).....	35856
HW-26V-2TL, 12.5 ft. (3.6 m).....	35858
HW-17, 18, 26 accessory kit.....	999126

V = Gas Valve.

Gouging Torch

Q4000 gouging torch package, 10 ft. (3 m)	Q61-082-009
--	-------------

Warrior 500i can be paralleled to utilize larger gouging rods.



Warrior Feed 304 Front Panel

Warrior Feed 304 Wire Feeder Data

Power Supply	Wire Spool Capacity, lbs. (kg)	Max. Spool Diameter, in. (mm)	Wire Feed Speed, ipm (m/min)	Dimensions (LxWxH), in. (mm)	Weight Enclosed, lbs. (kg)	Wire Dimensions, in. (mm)	
42 VAC, 50/60 Hz	44 (18)	12 (300) ¹	32-1000 (0.8-25)	27 x11x16 (690 x 275 x 420)	33 (15)	Steel	.023-1/16 (0.6-1.6)
						Stainless steel	.023-1/16 (0.6-1.6)
						Aluminum	.040-1/16 (0.8-1.6)
						Cored wire	.030-1/16 (0.9-1.6)

¹Enclosed.

ESAB Welding and Cutting Products

United States / esabna.com / 1.800.ESAB.123 Canada / esab.ca / 1.877.935.3226 Mexico / esab.com.mx / (81) 8305.3700

Warrior™ 500i

with Warrior Feed 304



Warrior Feed 304 Wire Feeder Wear Parts

Wire Diameter, in. (mm)	Wire Type	1 Feeder Roller (4 required)	2 Inlet Nozzle	3 Intermediate Nozzle	4 Outlet Nozzle	Groove Type	Marking
023/.030 (0.6-0.8)	Fe, Ss, C	0459052001	0455049001	0455072002	0469837880	V	0.6 S2 / 0.8 S2
.030/.035-.040 (0.8/0.9-1.0)	Fe, Ss, C	0459052002	0455049001	0455072002	0469837880	V	0.8 S2 / 1.0 S2
.035-.040/.045 (0.9-1.0/1.1)	Fe, Ss, C	0459052003	0455049001	0455072002	0469837880	V	1.0 S2 / 1.2 S2
.052/1/16 (1.3/1.6)	Fe, Ss, C	0459052013	0455049001	0455072002	0469837880	V	1.4 S2 / 1.6 S2
.035-.040/.045 (0.9-1.0/1.1)	C	0458825001	0455049001	0455072002	0469837880	V-K	1.0 R2 / 1.2 R2
.045/.045 (1.1/1.1)	C	0458825010	0455049001	0455072002	0469837880	V-K	1.2 R2 / 1.2 R2
.045/.052 (1.1/1.3)	C	37319	0455049001	0455072002	0469837880	V-K	1.2 R2 / 1.4 R2
1/16-5/64 (1.6-2.0)	C	37320	0455049001	0455072002	0469837880	V-K	1.6 R2
.035-3/64 (0.8-0.9)	Al	36860	0455049001	0456615001	0469837881	U	0.8 A2 / 1.0 A2
3/64-1/16 (0.9-1.6)	Al	36861	0455049001	0456615001	0469837881	U	1.2 A2 / 1.6 A2

C = cored wire, K = knurled groove.
 'As delivered.

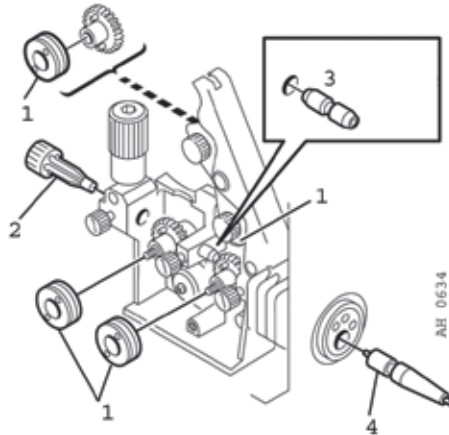

Specifications

Warrior 500i	
Input voltage	380/460/575V, 3ph, 50/60Hz
Permitted load at: 60% duty cycle 100% duty cycle	500A/40 V 400A/36 V
Setting range: GMAW/FCAW (MIG)/GTAW (TIG) SMAW (STICK)	16-500A 4-500A
Open circuit voltage	54V
Open circuit power	500W
Power factor at maximum current	0.92
Efficiency at maximum current	88%
Dimensions, LxWxH, in. (mm)	28.1x12.8 x18.5 (712x325x470)
Weight, lbs. (kg)	115 (52)
Operating temperature, °F (°C)	14 to 104 (-10 to 40)
Enclosure class	IP 23

ESAB Welding and Cutting Products

USA: www.esabna.com / 1.800.ESAB.123 | Canada: www.esab.ca / 1.877.935.3226 | Mexico: www.esab.com.mx / (81) 8305-3700